

## Tubular and Process Assemblies

### Elements and Assemblies

Watlow tubular elements and assemblies are primarily used for direct immersion in water, oils, viscous materials, solvents, process solutions and molten materials as well as air and gases.

Additionally, round and flat surface tubular elements (WATROD and FIREBAR® heaters respectively) can be used for surface heating.

WATROD and FIREBAR heating elements may be purchased separately, or fabricated into process heating assemblies, including:

- Screw plug
- Flange
- Circulation
- Booster
- Engine Preheater
- Over-the-Side
- Vertical Loop
- Drum
- Duct

Both elements and assemblies are available from stock. They can be configured with a variety of watt and volt ratings, terminations, sheath materials and mounting options to satisfy the most demanding applications.

If our stock products do not meet your application needs, Watlow can custom engineer the optimum heater.

#### Performance Capabilities

- Sheath temperatures up to 1800°F (983°C)
- Assembly wattages to 2.2 megawatts
- Process assembly ratings up to 1000 psi (70 kg/cm<sup>2</sup>)
- Watt densities up to 120 W/in<sup>2</sup> (18.6 W/cm<sup>2</sup>)



Assemblies, left to right: WATROD duct, WATROD screw plug, circulation and FIREBAR flange heater. WATROD and FIREBAR elements are in front.

- Enhanced performance beyond these specifications available from Watlow Process Systems.®

#### Features and Benefits

- **36 standard bend formations** enable designing the heating element around available space to maximize heating efficiency.
- **FIREBAR flat surface geometry** enhances heat transfer in both immersion and air applications, and surface heating, too. Increased surface area per linear inch allows heaters to run cooler in viscous materials.

- **Wattages from 95 watts to 2.2 megawatts** (on individual elements and assemblies respectively) make tubular heaters one of the most versatile electric heating sources available.

#### Applications

- Liquids
- Air
- Gases
- Molten materials
- Contact surface heating
- Radiant surface heating

® Watlow Process Systems can design thermal systems to meet specific performance criteria. Contact your Watlow representative for details.

# Tubular and Process Assemblies

## Elements and Assemblies

The following two charts will help you select an appropriate heater based on your application and watt density restrictions. These charts are application driven. The total

wattage required by your application should be known before selecting a specific heater type(s) from the stock tables. If your required wattage is not known, please

consult your Watlow representative. Once the heater type has been identified, turn to the appropriate product section for information on the element or assembly.

### Element and Assembly Selection Guide

To identify the tubular heater type best suited to your application, consult the *Element and Assembly Selection Guide*.

In most cases Watlow recommends using single tubular heating elements for low kilowatt applications.

Assemblies are better suited for large kilowatt applications to heat liquids, air or gases.

When selecting a heater according to watt density, be sure to consider the following:

- Liquid viscosity at start up and at process temperature
- Operating temperature
- Chemical composition

Under the **"Heating Method"** column in the *Element and Assembly Selection Guide* locate the method that applies to your application to find the recommended "Heater Type."

After identifying the heater type(s) suitable for your application, refer to the *Supplemental Applications Chart* for further application data. This chart will assist you in selecting the appropriate watt density and sheath material for your specific application. It also presents the performance characteristics for both WATROD and FIREBAR elements.

### Element and Assembly Selection Guide

Application	Heating Method	Heater Type
<b>Liquids:</b>		
Acids	Direct immersion (circulating/non-circulating)	FIREBAR, WATROD, Screw Plug, Flange, Over-the-Side, Vertical Loop, and Pipe Insert
Caustic Soda 12% Concentrate 10% Concentrate 75% Concentrate	Direct immersion (circulating/non-circulating)	WATROD, Screw Plug, Square Flange, Flange, Over-the-Side, Vertical Loop, Circulation, and Pipe Insert
Degreasing Solutions	Direct immersion (circulating/non-circulating)	FIREBAR, WATROD, Screw Plug, Square Flange, Flange, Over-the-Side, and Pipe Insert
Electroplating	Direct immersion (circulating/non-circulating)	FIREBAR, WATROD, Screw Plug, Square Flange, Flange, Over-the-Side, Drum, Vertical Loop and Pipe Insert
Ethylene Glycol 50% Concentrate 100% Concentrate	Direct immersion (circulating/non-circulating)	FIREBAR, WATROD, Screw Plug, Flange, Over-the-Side, Circulation, Booster, and Engine Preheater
Oils Asphalt Fuel Oils Light Grades 1 & 2 Medium Grades 4 & 5 Heavy Grade 6 & Bunker C Heat Transfer Lubricating SAE 10, 20, 30 SAE 40, 50 API STD 614 Vegetable (Cooking)	Direct immersion (circulating/non-circulating)	FIREBAR, WATROD, Screw Plug, Square Flange, Flange, Over-the-Side, Drum, Vertical Loop, Circulation, Booster, and Pipe Insert
Paraffin or Wax	Direct immersion (circulating/non-circulating)	FIREBAR, WATROD, Screw Plug, Square Flange, Flange, Over-the-Side, Drum, and Pipe Insert

CONTINUED 

# Tubular and Process Assemblies

## Elements and Assemblies

### Element and Assembly Selection Guide

Application	Heating Method	Heater Type
Water Clean Deionized Demineralized Potable Process	Direct immersion (circulating/non-circulating)	FIREBAR (non-process water only) WATROD, Screw Plug, Screw Plug with Control Assembly, Square Flange, Flange, Over-the-Side, Drum, Vertical Loop, Circulation, Booster, Engine Preheater and Pipe Insert
<b>Air:</b>	Direct (forced or natural convection)	FIREBAR, WATROD, FINBAR, WATROD Enclosure Heater, Screw Plug, Flange, Circulation, and Duct
<b>Gas:</b> Hydrocarbons, Nitrogen, Oxygen Ozone, Steam	Direct (forced)	FIREBAR, WATROD, Screw Plug, Flange, and Circulation
<b>Molten Materials:</b> Aluminum Lead Salt Solder	Indirect (radiant) Direct (non-circulating) Direct (non-circulating) Direct (non-circulating)	WATROD FIREBAR and WATROD FIREBAR and WATROD FIREBAR and WATROD
<b>Surface Heating:</b> Dies, Griddles, Molds, Platens	Direct	FIREBAR and WATROD

### Supplemental Applications Chart

This *Supplemental Applications Chart* is provided in addition to the *Element and Assembly Selection Guide*. This chart will help you select watt density and sheath

materials for either WATROD or FIREBAR heating elements according to the specific media being heated.

For example, if you're heating

vegetable oil, either WATROD or FIREBAR elements at 30 and 40 watts per square inch respectively (4.6 and 6.2 W/cm<sup>2</sup>) with 304 stainless steel sheath can be used.

### Supplemental Applications Chart

Heated Material	Maximum Operating Temperature °F (°C)	WATROD Element		FIREBAR Element		Sheath Material
		Maximum Watt Density W/in <sup>2</sup> (W/cm <sup>2</sup> )	Sheath Material	Maximum Watt Density W/in <sup>2</sup> (W/cm <sup>2</sup> )	Sheath Material	
<b>Acid Solutions (Mild)</b>						
Acetic	180 (82)	40 (6.2)	316 Stainless Steel	40 (6.2)		Incoloy® 800
Boric (30% max.)	257 (125)	40 (6.2)	Titanium	40 (6.2)		304 Stainless Steel
Carbonic	180 (82)	40 (6.2)	Inconel® 600	40 (6.2)		304 Stainless Steel
Chromic	180 (82)	40 (6.2)	Titanium	N/A	N/A	N/A
Citric	180 (82)	23 (3.6)	Incoloy®	30 (4.6)		Incoloy® 800
Fatty Acids	150 (65)	20 (3.1)	316 Stainless Steel	30 (4.6)		Incoloy® 800
Lactic	122 (50)	10 (1.6)	316 Stainless Steel	N/A	N/A	N/A
Levulinic	180 (82)	40 (6.2)	Inconel® 600	40 (6.2)		304 Stainless Steel
Malic	122 (50)	10 (1.6)	316 Stainless Steel	16 (2.5)		Incoloy® 800
Nitric (30% max.)	167 (75)	20 (3.1)	316 Stainless Steel	30 (4.6)		Incoloy® 800
Phenol—2-4						
Disulfonic	180 (82)	40 (6.2)	316 Stainless Steel	40 (6.2)		Incoloy® 800
Phosphoric	180 (82)	23 (3.6)	Incoloy®	30 (4.6)		Incoloy® 800
Phosphoric (Aerated)	180 (82)	23 (3.6)	304 Stainless Steel	30 (4.6)		304 Stainless Steel

CONTINUED

Incoloy® and Inconel® are registered trademarks of Special Metals Corporation.

# Tubular and Process Assemblies

## Elements and Assemblies

### Supplemental Applications Chart

Heated Material	Maximum Operating Temperature °F (°C)		WATROD Element		FIREBAR Element			
			Maximum Watt Density W/in <sup>2</sup> (W/cm <sup>2</sup> )	Sheath Material	Maximum Watt Density W/in <sup>2</sup> (W/cm <sup>2</sup> )	Sheath Material		
Proponic (10% max.)	180	(82)	40	(6.2)	Copper	40	(6.2)	304 Stainless Steel
Tannic	167/180	(75/82)	23/40	(3.6/6.2)	Steel/304 S. Steel	40	(6.2)	304 Stainless Steel
Tartaric	180	(82)	40	(6.2)	316 Stainless Steel	40	(6.2)	Incoloy® 800
Acetaldehyde	180	(82)	10	(1.6)	Copper	16	(2.4)	Incoloy® 800
Acetone	130	(54)	10	(1.6)	304 Stainless Steel	16	(2.4)	304 Stainless Steel
Air	①	①	①	①	Incoloy®	①	①	Incoloy® 800
Alcyl Alcohol	200	(93)	10	(1.6)	Copper	16	(2.4)	Incoloy® 800
Alkaline Solutions	212	(100)	40	(6.2)	Steel	48	(7.4)	304 Stainless Steel
Aluminum Acetate	122	(50)	10	(1.6)	316 Stainless Steel	16	(2.5)	Incoloy® 800
Aluminum Potassium Sulfate	212	(100)	40	(6.2)	Copper	N/A	N/A	N/A
Ammonia Gas	①	①	①	①	Steel	①	①	304 Stainless Steel
Ammonium Acetate	167	(75)	23	(3.6)	Incoloy®	30	(4.6)	Incoloy® 800
Amyl Acetate	240	(115)	23	(3.6)	Incoloy®	30	(4.6)	Incoloy® 800
Amyl Alcohol	212	(100)	20	(3.1)	304 Stainless Steel	30	(4.6)	304 Stainless Steel
Aniline	350	(176)	23	(3.6)	304 Stainless Steel	30	(4.6)	304 Stainless Steel
Asphalt	200-500	(93-260)	4-10	(0.6 - 1.6)	Steel	6-12	(0.9 - 1.8)	304 Stainless Steel
Barium Hydroxide	212	(100)	40	(6.2)	316 Stainless Steel	40	(6.2)	Incoloy® 800
Benzene, liquid	150	(65)	10	(1.6)	Copper	16	(2.5)	304 Stainless Steel
Butyl Acetate	225	(107)	10	(1.6)	316 Stainless Steel	16	(2.5)	Incoloy® 800
Calcium Bisulfate	400	(204)	20	(3.1)	316 Stainless Steel	N/A	N/A	N/A
Calcium Chloride	200	(93)	5-8	(0.8 - 1.2)	Inconel® 600	N/A	N/A	N/A
Carbon Monoxide	—	—	①	①	Incoloy®	①	①	Incoloy®
Carbon Tetrachloride	160	(71)	23	(3.6)	Incoloy®	30	(4.6)	Incoloy®
Caustic Soda:								
2%	210	(98)	48	(7.4)	Incoloy®	—	—	Consult factory
10% Concentrate	210	(98)	23	(3.6)	Incoloy®	—	—	Consult factory
75%	180	(82)	23	(3.6)	Incoloy®	—	—	Consult factory
Citric Juices	185	(85)	23	(3.6)	Incoloy®	30	(4.6)	Incoloy®
Degreasing Solution	275	(135)	23	(3.6)	Steel	30	(4.6)	304 Stainless Steel
Dextrose	212	(100)	20	(3.1)	304 Stainless Steel	30	(4.6)	304 Stainless Steel
Dyes & Pigments	212	(100)	23	(3.6)	304 Stainless Steel	30	(4.6)	304 Stainless Steel

#### Electroplating Baths:

Cadmium	180	(82)	40	(6.2)	304 Stainless Steel	40	(6.2)	304 Stainless Steel
Copper	180	(82)	40	(6.2)	316 Stainless Steel	N/A	N/A	N/A
Dilute Cyanide	180	(82)	40	(6.2)	316 Stainless Steel	N/A	N/A	N/A
Rochelle Cyanide	180	(82)	40	(6.2)	316 Stainless Steel	N/A	N/A	N/A
Sodium Cyanide	180	(82)	40	(6.2)	316 Stainless Steel	N/A	N/A	N/A
Potassium Cyanide	180	(82)	40	(6.2)	316 Stainless Steel	40	(6.2)	304 Stainless Steel
Ethylene Glycol	300	(148)	30	(4.6)	Steel	40	(6.2)	304 Stainless Steel
Formaldehyde	180	(82)	10	(1.6)	304 Stainless Steel	16	(2.5)	304 Stainless Steel
Freon® Gas	300	(148)	2-5	(0.3 - 0.8)	Steel	①	①	304 Stainless Steel
Gasoline	300	(148)	23	(3.6)	Steel	30	(4.6)	304 Stainless Steel

CONTINUED 

① Consult your Watlow representative.  
Freon® is a registered trademark of  
E.I. du Pont de Nemours and Company.

# Tubular and Process Assemblies

## Elements and Assemblies

### Supplemental Applications Chart

Heated Material	Maximum Operating Temperature °F (°C)		WATROD Element			FIREBAR Element		
			Maximum Watt Density W/in <sup>2</sup> (W/cm <sup>2</sup> )		Sheath Material	Maximum Watt Density W/in <sup>2</sup> (W/cm <sup>2</sup> )		Sheath Material
Gelatin Liquid	150	(65)	23	(3.6)	304 Stainless Steel	30	(4.6)	304 Stainless Steel
Gelatin Solid	150	(65)	5	(0.8)	304 Stainless Steel	7	(1.0)	304 Stainless Steel
Glycerin	500	(260)	10	(1.6)	Incoloy®	12	(1.9)	304 Stainless Steel
Glycerol	212	(100)	23	(3.6)	Incoloy®	30	(4.6)	304 Stainless Steel
Grease:								
Liquid	—	—	23	(3.6)	Steel	30	(4.6)	304 Stainless Steel
Solid	—	—	5	(0.8)	Steel	7	(1.0)	304 Stainless Steel
Hydrazine	212	(100)	16	(2.5)	304 Stainless Steel	20	(3.1)	304 Stainless Steel
Hydrogen	①	①	—	—	Incoloy®	①	①	Incoloy® 800
Hydrogen Chloride	①	①	—	—	Inconel® 600	①	①	N/A
Hydrogen Sulfide	①	①	—	—	316 Stainless Steel (heavy wall)	①	①	N/A
Magnesium Chloride	212	(100)	40	(6.2)	Inconel® 600	40	(6.2)	Incoloy® 800
Magnesium Sulfate	212	(100)	40	(6.2)	304 Stainless Steel	40	(6.2)	304 Stainless Steel
Magnesium Sulfate	212	(100)	40	(6.2)	316 Stainless Steel	40	(6.2)	304 Stainless Steel
Methanol Gas	①	①	—	—	304 Stainless Steel	①	①	304 Stainless Steel
Methylamine	180	(82)	20	(3.1)	Inconel® 600	30	(4.6)	304 Stainless Steel
Methylchloride	180	(82)	20	(3.1)	Copper	N/A	N/A	N/A
Molasses	100	(37)	4-5	(0.6 - 0.8)	304 Stainless Steel	5-8	(0.8 - 1.2)	304 Stainless Steel
Molten Salt Bath	800-900	(426-482)	25-30	(3.8 - 4.6)	Monel®	N/A	N/A	N/A
Naphtha	212	(100)	10	(1.6)	Steel	16	(2.5)	304 Stainless Steel

### Oils

Fuel Oils:								
Grades 1 & 2 (distillate)	200	(93)	23	(3.6)	Steel	30	(4.6)	304 Stainless Steel
Grades 4 & 5 (residual)	200	(93)	13	(2.0)	Steel	16	(2.5)	304 Stainless Steel
Grades 6 & Bunker C (residual)	160	(71)	8	(1.2)	Steel	10	(1.6)	304 Stainless Steel
Heat Transfer Oils: ②								
Static	500	(260)	16	(2.5)	Steel	23	(3.6)	304 Stainless Steel
600	600	(315)	10	(1.6)	Steel	16	(2.5)	304 Stainless Steel
Circulating	500	(260)	23	(3.6)	Steel	30	(4.6)	304 Stainless Steel
600	600	(315)	15	(2.3)	Steel	20	(3.1)	304 Stainless Steel
Lubrication Oils:								
SAE 10, 90-100 SSU @ 130°F	250	(121)	23	(3.6)	Steel	30	(4.6)	304 Stainless Steel
SAE 20, 120-185 SSU @ 130°F	250	(121)	23	(3.6)	Steel	30	(4.6)	304 Stainless Steel
SAE 30, 185-255 SSU @ 130°F	250	(121)	23	(3.6)	Steel	30	(4.6)	304 Stainless Steel
SAE 40, -80 SSU @ 210°F	250	(121)	13	(2.0)	Steel	18	(2.7)	304 Stainless Steel
SAE 50, 80-105 SSU @ 210°F	250	(121)	13	(2.0)	Steel	18	(2.7)	304 Stainless Steel
Miscellaneous Oils:								
Draw Bath	600	(315)	23	(3.6)	Steel	30	(4.6)	304 Stainless Steel
Hydraulic	—	—	15 <sup>③</sup>	(2.3)	Steel	15 <sup>③</sup>	(2.3)	304 Stainless Steel
Linseed	150	(65)	50	(7.7)	Steel	60	(9.3)	304 Stainless Steel
Mineral	200	(93)	23	(3.6)	Steel	30	(4.6)	304 Stainless Steel
400	400	(204)	16	(2.5)	Steel	23	(3.6)	304 Stainless Steel
Vegetable/Shortening	400	(204)	30	(4.6)	304 Stainless Steel	40	(6.2)	304 Stainless Steel

CONTINUED

② Maximum operating temperatures and watt densities are detailed in Heat Transfer Oil charts on page 265.

③ Per API standards.

Monel® is a registered trademark of Special Metals Corporation.

# Tubular and Process Assemblies

## Elements and Assemblies

### Supplemental Applications Chart

Heated Material	Maximum Operating Temperature °F (°C)		WATROD Element		FIREBAR Element			
			Maximum Watt Density W/in <sup>2</sup> (W/cm <sup>2</sup> )	Sheath Material	Maximum Watt Density W/in <sup>2</sup> (W/cm <sup>2</sup> )	Sheath Material		
Paraffin or Wax (liquid)	150	(65)	16	(2.4)	Steel	20	(3.1)	304 Stainless Steel
Perchloroethylene	200	(93)	23	(3.6)	Steel	30	(4.6)	304 Stainless Steel
Potassium Chlorate	212	(100)	40	(6.2)	316 Stainless Steel	N/A	N/A	N/A
Potassium Chloride	212	(100)	40	(6.2)	316 Stainless Steel	N/A	N/A	N/A
Potassium Hydroxide	160	(71)	23	(3.6)	Monel®	N/A	N/A	N/A
Soap, liquid	212	(100)	20	(3.1)	304 Stainless Steel	30	(4.6)	304 Stainless Steel
Sodium Acetate	212	(100)	40	(6.2)	Steel	50	(7.7)	304 Stainless Steel
Sodium Cyanide	140	(60)	40	(6.2)	Incoloy®	50	(7.7)	Incoloy® 800
Sodium Hydride	720	(382)	28	(4.3)	Incoloy®	36	(5.5)	Incoloy® 800
Sodium Hydroxide	—	—	—	—	See Caustic Soda	—	—	—
Sodium Phosphate	212	(100)	40	(6.2)	Copper	50	(7.7)	304 Stainless Steel
Steam, flowing	300	(148)	10	(1.6)	Incoloy®	①	①	Incoloy® 800
	500	(260)	5-10	(0.8-1.6)	Incoloy®	①	①	Incoloy® 800
	700	(371)	5	(0.8)	Incoloy®	①	①	Incoloy® 800
Sulfur, Molten	600	(315)	10	(1.6)	Incoloy®	12	(1.8)	Incoloy® 800
Toluene	212	(100)	23	(3.6)	Steel	30	(4.6)	304 Stainless Steel
Trichlorethylene	150	(65)	23	(3.6)	Steel	30	(4.6)	304 Stainless Steel
Turpentine	300	(148)	20	(3.1)	304 Stainless Steel	25	(3.8)	304 Stainless Steel

#### Water

Clean	212	(100)	60	(9.3)	Incoloy®	45	(7)	Incoloy® 800
Deionized	212	(100)	60	(9.3)	316 SS (passivated)	90	(14)	Incoloy® 800
Demineralized	212	(100)	60	(9.3)	316 SS (passivated)	90	(14)	Incoloy® 800
Potable	212	(100)	60	(9.3)	Incoloy®	45	(7)	Incoloy® 800
Process	212	(100)	48	(9.3)	Incoloy®			Consult factory

① Consult your Watlow representative.

### Free Cross Sectional Area of WATROD and FIREBAR Circulation Heaters

Free cross sectional areas from the chart are in square feet.

Calculations are based on:

- Flange 12 inches and under, pipes are schedule 40
- Flanges 14 inches and above, pipes are standard wall thickness (0.375 inch/9.5 mm)
- All WATROD heating elements are 0.475 inch diameter (12 mm)

Circulation Heater Size Inches	Free Cross Sectional Area in Square Feet (Number of Elements in Parenthesis)			
<b>WATROD</b>				
2½ NPT	0.044	(3)		
3 Flange	0.044	(3)	0.037	(6)
4 Flange	0.074	(6)		
5 Flange	0.124	(6)	0.117	(9)
6 Flange	0.172	(12)	0.164	(15)
8 Flange	0.303	(18)	0.296	(21)
10 Flange	0.481	(27)	0.460	(36)
12 Flange	0.697	(36)	0.652	(54)
14 Flange	0.848	(45)	0.781	(72)
16 Flange	1.091	(72)	1.054	(87)
18 Flange	1.372	(102)	1.357	(108)
20 Flange	1.748	(108)	1.733	(114)
			1.017	(102)
			1.342	(114)
			1.704	(126)
<b>FIREBAR</b>				
2½ NPT	0.0417	(3)		
4 Flange	0.0692	(6)		
6 Flange	0.154	(15)		

# Tubular and Process Assemblies

## Elements and Assemblies

### Heat Transfer Oil Chart

Heat Transfer Fluid	Recommended Maximum Temperature °F (°C)		Flammability Data °F (°C)			Minimum Velocity Thru Heater in Feet/second at W/in <sup>2</sup> (M/second at W/cm <sup>2</sup> )				
	Process		Flash Point	Fire Point	Autoignition	8 (1.2)	16 (2.8)	23 (3.6)	30 (4.7)	
	F (°C)	°F (°C)	°F (°C)	°F (°C)	°F (°C)	W/in <sup>2</sup> (W/cm <sup>2</sup> )	W/in <sup>2</sup> (W/cm <sup>2</sup> )	W/in <sup>2</sup> (W/cm <sup>2</sup> )	W/in <sup>2</sup> (W/cm <sup>2</sup> )	
Calflo HTF	600 (316)	650 (343)	414 (212)	462 (239)	670 (354)	1.5 (0.5)	3 (0.9)	5 (1.52)	7 (2.1)	
Calflo AF	550 (288)	600 (316)	400 (204)	437 (225)	650 (343)	1.5 (0.5)	3 (0.9)	5 (1.52)	7 (2.1)	
Caloria HT-43	600 (316)	680 (360)	400 (204)	no data	no data	670 (354)	1.5 (0.5)	2.5 (0.75)	3 (0.9)	4 (1.22)
Dow therm® A	750 (399)	835 (446)	255 (124)	275 (135)	1150 (621)	0.5 (0.15)	1 (0.3)	2 (0.61)	3 (0.9)	
Dow therm® G	700 (371)	775 (413)	305 (152)	315 (157)	1150 (621)	0.7 (0.2)	1.5 (0.5)	2.5 (0.75)	3.5 (1.1)	
Dow therm® J	575 (302)	650 (343)	145 (63)	155 (68)	806 (430)	1 (0.3)	2 (0.61)	3 (0.9)	4.5 (1.37)	
Dow therm® LF	600 (316)	675 (357)	260 (127)	280 (138)	1020 (549)	0.7 (0.2)	1.5 (0.5)	2.5 (1.75)	3.5 (1.1)	
Dow therm® HT	650 (343)	700 (371)	no data	no data	no data	no data	1.5 (0.5)	2.5 (0.75)	3.5 (1.1)	5 (1.52)
Dow therm® Q	625 (329)	700 (371)	no data	no data	773 (412)	0.7 (0.2)	1.5 (0.5)	2.5 (0.75)	3.5 (1.1)	
Marlotherm S	662 (350)	698 (370)	374 (190)	no data	no data	932 (500)	1.5 (0.5)	3 (0.9)	5 (1.52)	7 (2.1)
Mobiltherm 603	590 (310)	625 (329)	380 (193)	no data	no data	no data	1.5 (0.5)	3 (0.9)	5 (1.52)	7 (2.1)
Multitherm IG-2	600 (316)	650 (343)	440 (227)	500 (260)	700 (371)	0.8 (0.24)	1.7 (0.52)	2.3 (0.7)	3 (0.9)	
Multitherm PG-1	600 (316)	640 (338)	340 (171)	385 (196)	690 (368)	1 (0.3)	2 (0.61)	3 (0.9)	4 (1.22)	
Para Cymene	600 (316)	650 (343)	117 (47)	152 (72)	817 (438)	0.7 (0.2)	1.5 (0.5)	2.5 (0.75)	3.5 (1.1)	
Syltherm 800	750 (399)	800 (427)	350 (177)	380 (193)	725 (385)	1.5 (0.5)	3 (0.9)	5 (1.52)	7 (2.1)	
Syltherm XLT	500 (260)	550 (288)	116 (47)	130 (54)	662 (350)	1.5 (0.5)	2.5 (0.75)	4 (1.22)	5 (1.52)	
Texatherm	600 (316)	640 (338)	430 (221)	no data	no data	no data	2 (0.61)	4 (1.22)	6 (1.83)	8 (2.4)
Thermia 33	600 (316)	650 (343)	455 (235)	495 (257)	no data	no data	1.5 (0.5)	3 (0.9)	5 (1.52)	7 (2.1)
Therminol 44	400 (204)	475 (246)	405 (207)	438 (228)	705 (374)	1 (0.3)	2 (0.61)	3 (0.9)	4 (1.22)	
Therminol 55	550 (288)	605 (318)	350 (177)	410 (210)	675 (357)	1.5 (0.5)	2.5 (0.75)	3.5 (1.1)	5 (1.52)	
Therminol 59	600 (316)	650 (343)	302 (150)	335 (168)	770 (410)	1.5 (0.5)	2.5 (0.75)	3.5 (1.1)	5 (1.52)	
Therminol 60	620 (327)	655 (346)	310 (154)	320 (160)	835 (448)	1.5 (0.5)	3 (0.9)	5 (1.52)	7 (2.1)	
Therminol 68	650 (343)	705 (374)	350 (177)	380 (183)	705 (374)	1.5 (0.5)	2.5 (0.75)	3 (0.9)	4.5 (1.37)	
Therminol 75	750 (399)	805 (429)	390 (199)	440 (227)	1000 (538)	1 (0.3)	2 (0.61)	3 (0.9)	4 (1.22)	
Therminol LT	600 (316)	650 (343)	134 (57)	150 (66)	805 (429)	1.5 (0.5)	2.5 (0.75)	4 (1.22)	5 (1.52)	
Therminol VP-1	750 (399)	800 (427)	255 (124)	280 (127)	1150 (621)	1 (0.3)	2 (0.61)	3 (0.9)	4 (1.22)	
U-Con 500	500 (260)	550 (288)	540 (282)	600 (316)	750 (399)	1 (0.3)	2 (0.61)	3 (0.9)	4 (1.22)	

# Tubular and Process Assemblies

## Elements and Assemblies

### Agency Recognition

UL® and CSA recognition information charts are provided to ensure:

- Safety parameters in relationship to stated voltage and amperage
- Approved sheath materials, end seals and assembly electrical enclosures

Watlow believes that UL® and CSA recognition information is necessary to confirm the reliability of our heating products in relationship to your application. As such, the accompanying Agency Recognition charts illustrate the extent of coverage each heater type

provides. Specific end use application information is required for each agency marking. Some products carry U.S. and Canada approvals.



### UL® Recognition and Listing

#### File Number E52951 (UL 499) — Component Recognition

All information for UL file #E52951 can be found in the UL® Directory, Volume I, under "Heaters Miscellaneous" (Classification KSOT2).

### Elements

WATROD Diameter inch (mm)	Code Number Designation	Max. Volts	Max Amps	Max. Watt Density		Min. Bend Radius		Allowable Sheath Materials	End Seal Types
				W/in <sup>2</sup>	W/cm <sup>2</sup>	inch	(mm)		
0.210 (6.0)	<b>U0-xx</b>	250	15	N/A	N/A	1/6	(2)	Aluminum,	
0.260 (6.6)	<b>RA</b> series <b>U1-xx</b>	250	15	N/A	N/A	1/6	(2)	Copper,	Epoxy resin,
0.315 (8.0)	<b>RB</b> series <b>U3-xx</b>	480	30	N/A	N/A	1/6	(2)	Incoloy®,	Lavacone,
0.335 (8.5)	<b>UE-xx</b>	480	30	N/A	N/A	3/6	(5)	Inconel®,	Silicone resin,
0.375 (9.5)	<b>RD, RS</b> series <b>U5-xx</b>	480	30	N/A	N/A	3/6	(5)	Stainless steel,	Silicone rubber,
0.430 (10.9)	<b>RC</b> series <b>U6-xx</b>	600	40	N/A	N/A	5/2	(4)	Steel,	Glass,
0.475 (12.0)	<b>RG</b> series <b>U7-xx</b>	600	40	N/A	N/A	3/6	(5)	Titanium,	ULTRAGARD,
0.490 (12.4)	<b>U8-xx</b>	600	40	N/A	N/A	3/6	(5)	Special Request	SF 99
0.625 (15.9)	<b>U9-xx</b>	600	40	N/A	N/A	1/6	(11)		

FIREBAR® Height inch (mm)	Code Number Designation	Max. Volts	Max. Amps	Max. Watt Density		Min. Bend Radius		Allowable Sheath Materials	End Seal Types
				W/in <sup>2</sup>	W/cm <sup>2</sup>	Major Axis inch (mm)	Minor Axis inch (mm)		

### Air or Immersion Heating

3/8 (16)	<b>FA, FS</b> series <b>A-xx</b>	250	N/A	33	(5.1)	1 (25)	1/2 (13)	Incoloy®	Epoxy resin
1 (25.4)	<b>FB, FS</b> series	250	N/A	33	(5.1)	1 (25)	1/2 (13)	Stainless steel	Lavacone
								Titanium	Silicone resin
									Silicone rubber
									ULTRAGARD

### Liquid Immersion Heating Only

3/8 (16)	<b>FA, FS</b> series <b>U-xx</b>	480	N/A	160	(24.7)	1 (25)	1/6 (2)	Incoloy®	Epoxy resin
1 (25.4)	<b>FB, FS</b> series	480	N/A	160	(24.7)	1 (25)	1/6 (2)	Stainless steel	Lavacone
								Titanium	Silicone resin
									Silicone rubber
									ULTRAGARD

**Note:** UL® and CSA must be requested at the time the order is placed.

UL® is a registered trademark of the Underwriter's Laboratories, Inc.

# Tubular and Process Assemblies

## Elements and Assemblies

### Assemblies

Refer to applicable WATROD and FIREBAR elements for maximum voltage, watt density and sheath materials.

Heater Type	Code Number Designations	Electrical Enclosure Options
Screw Plug	All catalog "B" models Series <b>U1</b> to <b>U9</b>	General purpose with or without thermostat
Flange	All catalog models <b>FE, FG, FH, FK, FL, FM, FN, FO, FP, FR, FS, FT, FW</b> —Series <b>U1</b> to <b>U9</b>	General purpose with or without thermostat
Circulation	All catalog models <b>CB, CF, CP</b> Series <b>U1</b> to <b>U9</b>	General purpose with or without thermostat
Over-the-Side	All catalog "OL," "OR" and "VL" models Series <b>U1</b> to <b>U9</b> , <i>except U2 and U4</i>	Moisture resistant with or without thermostat
Duct	All catalog "D6 to D125" models Series <b>U1</b> to <b>U9</b> , <i>except U2 and U4</i>	General purpose enclosure only (Incoloy® sheath only)

### File Number E56488 (UL 1030)—Water Immersion Only (Classification UBJY2). — Component Recognition

#### Elements

WATROD Diameter inch (mm)	Code Number Designation	Max. Volts	Max Amps	Max. Watt Density		Min. Bend Radius		Allowable Sheath Materials	End Seal Types
				W/in <sup>2</sup>	W/cm <sup>2</sup>	inch	(mm)		
0.315 (8.0)	T series Example: <b>T085CN3S</b>	480	7	120	(18.5)	1/8	(3)	Copper Incoloy® Stainless steel	Epoxy RTV Silicone
0.375 (9.5)		480	7	120	(18.5)	1/8	(3)		
0.430 (10.9)		575	7	120	(18.5)	5/16	(8)		
0.475 (12.0)		575	7	120	(18.5)	5/16	(8)		
0.490 (12.4)		575	7	120	(18.5)	5/16	(8)		
0.625 (15.9)		575	7	120	(18.5)	5/16	(8)		

FIREBAR® Height inch (mm)	Code Number Designation	Max. Volts	Max. Amps	Max. Watt Density		Min. Bend		Allowable Sheath Materials	End Seal Types
				W/in <sup>2</sup>	W/cm <sup>2</sup>	Major Axis inch (mm)	Minor Axis inch (mm)		
1 (25.4)	T series Example: <b>T085HN3W</b>	250	N/A	80	(12.4)	1 (25)	1/32 (4)	Incoloy® Stainless steel	Epoxy RTV Silicone

### Assemblies

Refer to applicable WATROD and FIREBAR elements for maximum voltage, watt density and sheath materials.

Heater Type	Code Number Designations	Electrical Enclosure Options
Screw Plug	Models <b>T3, T5, T6, T7, T8, T9</b> Example: <b>T336xxxx</b>	General purpose without thermostat
Flange	Models <b>T3, T5, T6, T7, T8, T9</b> Example: <b>T621xxxx</b>	General purpose without thermostat

**Note:** UL® and CSA must be requested at the time the order is placed.

# Tubular and Process Assemblies

## Elements and Assemblies

**File Number MH26554 (UL 574)—Electric Oil Heaters (Classification MDST2).**  
**— Component Recognition or Listing (Consult factory if UL® Listed marking is desired)**

### Elements

For reference only, marking applies only to assemblies noted below.

WATROD Diameter inch (mm)	Code Number Designation	Max. Volts	Max Amps	Max. Watt Density		Min. Bend Radius		Allowable Sheath Materials	End Seal Types
				W/in <sup>2</sup>	W/cm <sup>2</sup>	inch	(mm)		
0.260 (6.6)	series <b>1-xx</b>	250	15	23	(3.56)	1/6	(2)	Steel, Inconel®	Epoxy resin, silicone resin
0.315 (8.0)	series <b>3-xx</b>	480	30	23	(3.56)	1/6	(2)	Stainless steel	Silicone rubber
0.375 (9.5)	series <b>5-xx</b>	480	30	23	(3.56)	3/6	(5)		
0.430 (10.9)	series <b>6-xx</b>	600	40	23	(3.56)	5/2	(4)	Monel®	Lavacone
0.475 (12.0)	series <b>7-xx</b>	600	40	23	(3.56)	3/6	(5)		
0.490 (12.4)	series <b>8-xx</b>	600	40	23	(3.56)	3/6	(5)	Hastelloy®	ULTRAGARD
0.625 (15.8)	series <b>9-xx</b>	600	40	23	(3.56)	1/6	(11)		

### Assemblies

Refer to applicable WATROD elements for maximum voltage, watt density and sheath materials.

Heater Type	Code Number Designations	Electrical Enclosure Options
Screw Plug	Models <b>BCS and BGS</b> series <b>1-xx</b> thru <b>9-xx</b> , excluding series <b>2-xx</b> and <b>4-xx</b>	Enclosure Types 1 or 4, with or without thermostat. Thermostat shall be Watlow Type 4, 12 or 12A

**Note:** UL® and CSA must be requested at the time the order is placed.

### Declaration of Conformity

The Low Voltage Directive (LVD) (73/23/EEC) states that electrical and electronic equipment placed on the market in the European Union (EU) must be safe. The CE Marketing Directive (93/68/EEC) for the LVD came into force on January 1, 1995, subject to a two-year transition period. All heaters operating on a supply voltage of between 50 and 1000V~(ac), and between 75 and 1500V=(dc) fall within the scope of the LVD.

The Self Declaration of Conformity shown on the right, backed by our risk assessment and technical file, assure that the product series shown on the Declaration meet the EU requirements. The Declaration is not applicable to any of our heaters intended for use in an explosive atmosphere, or for radiological and medical purposes.

**CE**

**Declaration of Conformity**

**Watlow Industries**  
 6 Industrial Loop Road  
 Hannibal, MO 63401  
 USA

Declares that the following product(s):

Product(s) Code Number(s)	Description
Series B may be followed by additional letters and numbers	Screw Plug
Series 12 may be followed by additional letters and numbers	Disc Heaters
Series 2 may be followed by additional letters and numbers	Flange Heater
C prefix to Series B and F	Circulation Heater
Series C and V may be followed by additional letters	Over-the-Side Heaters
Min. Catalog Numbers 1, 2, 3, 4, 5, 6, 7, 8 & 9 may be followed by a series of numbers, dashes and/or letters. May be preceded by "C"	Miscellaneous

\* Series D Heaters not to be used in water or liquid applications  
 ATEXED File No.: sp-000 F4C  
 ATEXED F4C/EN/CY: 2000 02

Meets the essential requirements of the following European Union Directive(s) using the relative number(s) of the harmonized standards and related documents shown:

**73/23/EEC Low Voltage Directive**

Safety of household and similar electrical appliances  
 Part 2: Particular requirements for room heaters  
 EN 60335-2-30  
 EN 60335-2-43 Part 2: Particular requirements for commercial electric water boilers and liquid heaters  
 Reference Watlow Technical File No. D100706101

Watlow Industries  
 6 Industrial Loop Road  
 Hannibal, Missouri, USA 63401

Place of Issue: Hannibal, MO, USA  
 Date of Issue: 08 September 2000  
 Signature of Authorized Representative: *Steve Rhoads*

Name of Authorized Representative: Steve Rhoads  
 Title of Authorized Representative: Plant Manager

File: HANDEC.DOC Doc. No: 226-01-18 Revised: 09/08/00

Hastelloy® is a registered trademark of Haynes International.

# Tubular and Process Assemblies

## Elements and Assemblies

### CSA Certification

#### File Number LR 31388

All information for CSA file LR 31388 can be found in the *CSA List of Certified Electrical Equipment* catalog, Volume II, under Heaters—Miscellaneous.

### Elements

Heater Type— Diameter/Height inch (mm)	Code Number Designation	Max. Volts	Max. Watt Density W/in <sup>2</sup> (W/cm <sup>2</sup> )		Allowable Sheath Materials <sup>①</sup>	End Seal Type (All Diameters)
<b>WATROD:</b>						
0.260 (6.6)	All catalog models, <b>1-xx</b>	600	120	(18.5)	Copper	
0.315 (8.0)	All catalog models, <b>3-xx</b>	600	120	(18.5)	Incoloy®	Epoxy resin,
0.375 (9.5)	All catalog models, <b>5-xx</b>	600	120	(18.5)	Stainless steel	Lavacone,
0.430 (10.9)	All catalog models, <b>6-xx</b>	600	120	(18.5)	Steel	Silicone resin,
0.475 (12.0)	All catalog models, <b>7-xx</b>	600	120	(18.5)	Titanium	Silicone rubber
0.490 (12.4)	All catalog models, <b>8-xx</b>	600	120	(18.5)	Special request	ULTRAGARD
0.625 (15.9)	All catalog models, <b>9-xx</b>	600	120	(18.5)		
<b>FIREBAR:</b>						
$\frac{5}{8}$ (15.9)	<b>FA, FS</b> models, <b>4-xx</b>	480	120	(18.5)	Incoloy®	Epoxy resin,
1 (25.4)	<b>FB, FS</b> models, <b>2-xx</b>	480	120	(18.5)	Stainless steel Titanium	Lavacone, Silicone resin, Silicone rubber

**Note:** Heating elements are certified only for use in equipment where the acceptability of the construction combination is determined by the Canadian Standards Association.

① Some sheath materials not available on all diameters. Consult factory.

### Assemblies

Heater Type	Code Number Designations	Electrical Enclosure Options
Screw Plug	All catalog "B" models Series <b>1-xx</b> to <b>9-xx</b>	General purpose with or without thermostat Enclosure 4 with or without thermostat
Flange	All catalog models <b>FM, FN, FO, FP, FR, FS, FT, FW</b> Series <b>1-xx</b> to <b>9-xx</b>	General purpose with or without thermostat *Enclosure 4 with or without thermostat
Circulation	All catalog models <b>CBD, CBE, CBL, CFM, CFN, CFO, CFP, CFR, CFS, CFT, CFW</b> —Series <b>1-10</b> to <b>9-10</b>	General purpose with or without thermostat *Enclosure 4 with or without thermostat
Over-the-Side	All catalog "OL" and "OR" models Series <b>1-30</b> to <b>9-30</b>	Enclosure 4 with or without thermostat
Duct	All catalog "D" and "MDH" models Series <b>1-1</b> to <b>9-1</b>	General purpose enclosure only

\* 4, 5, 6 and 8 inch flange size only.

### File Number LR 61707—Heater Assemblies—Miscellaneous—For Hazardous Locations

Heater Type	Code Number Designations	Electrical Enclosure Options
Screw Plug	All catalog "B" models Series <b>1-xx</b> to <b>9-xx</b>	Class I, Groups B, C and D
Flange	All catalog models <b>FM, FN, FO, FP, FR, FS, FT, FW</b> Series <b>1-xx</b> to <b>9-xx</b>	Class I, Groups B, C and D, and Enclosure 4 with or without thermostat
Circulation	All catalog models <b>CFM, CFN, CFO, CFP, CFR, CFS, CFT, CFW</b> Series <b>1-10</b> to <b>9-10</b>	Class I, Groups B, C and D, and Enclosure 4 with or without thermostat

**Note:** UL® and CSA must be requested at the time the order is placed.

# Tubular and Process Assemblies

---

Elements and Assemblies

## Tubular and Process Assemblies

### WATROD Heating Elements

#### Single- and Double-Ended Elements

Available in single- or double-ended termination styles, the versatile and economical WATROD tubular heating element lends itself to virtually the entire range of immersion and air heating applications.

The single-ended WATROD tubular design has both terminals at one end. The opposite end is sealed. Standard 12-inch (305 mm) flexible lead wires are crimp connected to the terminal pin and have silicone-impregnated fiberglass oversleeves.

The double-ended WATROD, with its round cross-sectional geometry, is highly adaptable for bending—especially when bending is performed in the field.

Watlow's new double-sided multicoil tubular elements offer various combinations of resistor coils and thermocouples inside one sheath. They have the ability to sense the heater's internal temperature accurately every time, or offer three-phase capability in one element. Both single- and double-ended WATRODs share many construction features that deliver long life—the resistance wire is centered in the heater sheath and electrically insulated with compacted, high-grade magnesium oxide for superior heating performance.

WATROD heating elements have a variety of mounting and termination options that make them highly popular among industrial customers.

#### Single-Ended WATROD Performance Capabilities

- Watt densities to 45 W/in<sup>2</sup> (6.9 W/cm<sup>2</sup>)
- UL® and CSA component recognition to 240V~(ac)
- Incoloy® and stainless steel sheath temperatures to 1200°F (650°C)

#### Double-Ended WATROD Performance Capabilities

- Watt densities up to 120 W/in<sup>2</sup> (18.6 W/cm<sup>2</sup>)

UL® is a registered trademark of Underwriter's Laboratories, Inc.

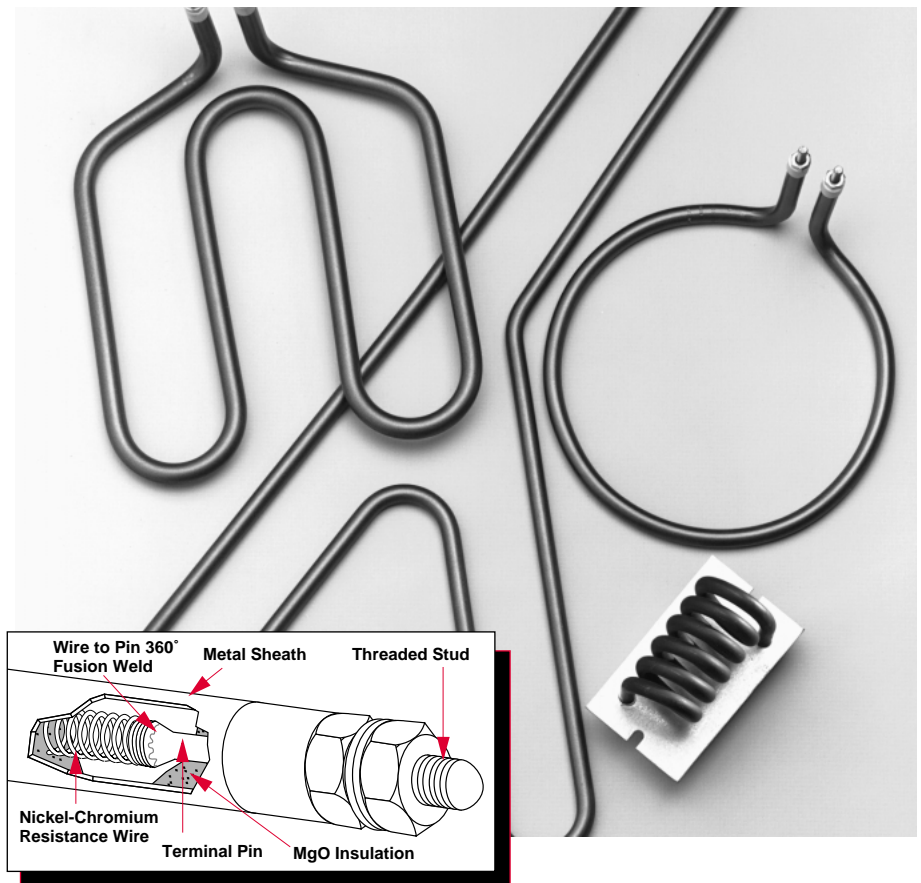

- UL® and CSA component recognition to 480 and 600V~(ac) respectively
- Inconel® sheath temperatures to 1800°F (982°C)
- Incoloy® sheath temperatures to 1600°F (870°C)
- Stainless steel sheath temperatures to 1200°F (650°C)
- Steel sheath temperatures to 750°F (400°C)
- Copper sheath temperatures to 350°F (175°C)
- Inconel® 600 sheath temperatures to 1800°F (982°C)

#### Features and Benefits

- **Precision wound nickel-chromium resistance wire** distributes heat evenly to the sheath for optimum heater performance.
- **Silicone resin seals** protect against moisture contamination and are rated to 390°F (200°C).

- **MgO insulation filled sheath** maximizes dielectric strength, heat transfer and life.
- **Standard sheath materials include:** copper, steel, 316 stainless steel and Incoloy®. Optional materials, available on made-to-order, include 304 stainless steel, Inconel® Monel® and titanium.
- **36 standard bend formations** allow forming the heating element to the application. Spirals, compound bends and multi-axis and multi-plane configurations.
- **Resistance wire fusion welded to the terminal pin** for a stronger, positive electrical connection.
- **Stainless steel studs** are fusion welded to terminal pins for mechanical strength with ceramic insulators.
- **Popular termination, mounting and moisture seal options available.**

Incoloy®, Inconel® and Monel® are registered trademarks of Special Metals Corporation.

## Tubular and Process Assemblies

### WATROD Heating Elements

#### High Temperature Tubular Double-Ended Elements



Watlow manufactures high temperature tubular heaters to bridge the gap between standard tubular heaters and Watlow multicell heaters. This new tubular is well suited for process air heating applications in excess of 1300°F (704°C), resulting in a maximum sheath temperature of 1800°F (983°C). Controlled lab testing between the new design and

current tubular designs show an increase in life of approximately 50 percent.

The high temperature tubular consists of an engineered tubing with an outer sheath of Inconel® 600 and a special internal construction. The outer sheath offers high temperature capabilities, reduced oxidation, as well as corrosion resistance.

The new tubular offering is available in 0.430 and 0.375 inch diameters that are configurable either as formed tubulars or process heaters. The heaters can also be welded to flanges and plates for mounting purposes. Maximum sheath length available is 275 inches for the 0.430 inch and 0.375 inch diameters. The factory should be contacted for longer sheath lengths.

#### Features and Benefits

- **Inconel® 600 sheath material and a special internal construction** assures high temperature performance and corrosion protection in tough applications.

- **0.375 in and 0.430 in diameters** allow heater to be configured to existing tubular designs that may be experiencing short life.
- **Dual-ended termination** can be installed into flanges and screw plugs similarly to standard product configurations.
- **Bendable in standard formations** makes the heater easy to apply in a wide variety of applications.

#### Applications

- High temperature ovens and furnaces
- Radiant heating
- Drying
- Environmental—VOC abatement
- Process air heating: duct heaters, circulation heaters
- Vacuum applications
- Flue gas cleaning (desulfurization)
- Fluidized beds

### Sheath Temperature Versus Oven Temperature at Various Watt Density

This chart is used to verify the correct watt density for an oven application assuming no air flow. To use the chart, first select the oven process temperature on the X axis, using the chosen watt density read the sheath temperature rise above oven temperature from the Y axis. This number should then be added to oven temperature. If this number is greater than 1800°F (982°C), a lower watt density should be chosen.

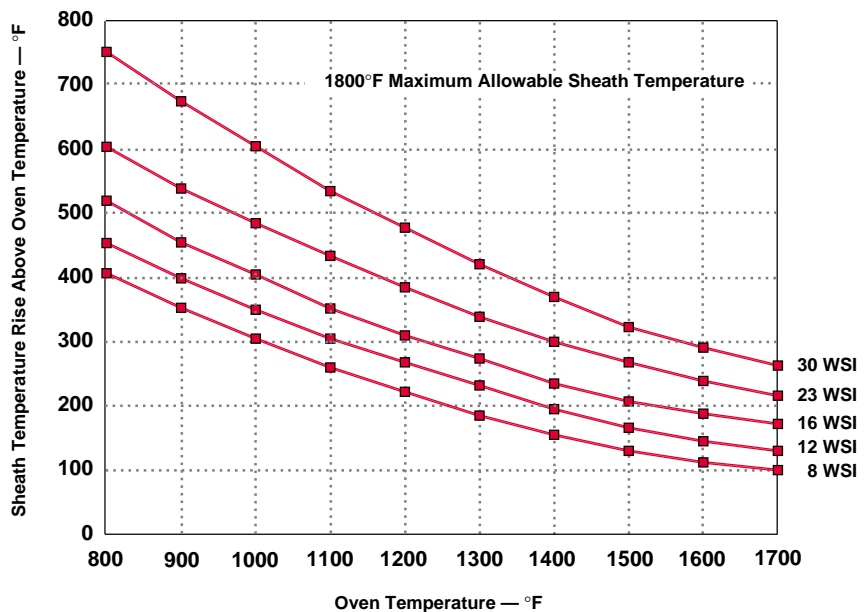

## Tubular and Process Assemblies

### WATROD Heating Elements

#### High Temperature Tubular Double-Ended Elements

Continued

### Heater Life Estimate Service

#### High Temperature Heater Comparisons

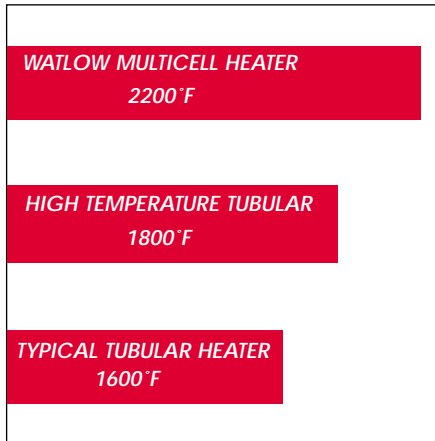

\*Assuming normal design practices.

Watlow now provides an industry first service with the offering of the high temperature tubular. By providing operating parameters Watlow can provide customers with the estimated life of the heater. To get this information the following information should be provided:

- Heater voltage
- Heater wattage
- Heater diameter (0.430 in or 0.375 in)
- Heated length
- Bend configuration and dimensions (# of bends and radius)
- Application including process temperature
- Power switching device and cycle time (SCR, etc.)

WATROD

F.O.B.: Hannibal, Missouri

#### How to Order

To order please specify:

- Volts
- Watts
- Heater diameter (0.430 in or 0.375 in)
- Termination type or style (studs, lead wire)
- Heated length
- Cold end length
- Overall sheath length
- Formation
- Mounting option (bulkheads, brackets, etc.)

## Tubular and Process Assemblies

### WATROD Heating Elements

#### Multicoil Single- or Double-Ended Elements



Watlow's new tubular element with multiple coils and/or thermocouples inside one sheath answers the need for a versatile, innovative tubular heater. Our new, patent-pending method of packaging a thermocouple inside of a heater with one or more resistance coils, gives the ability to sense a heaters' internal temperature accurately, every time.

Moreover, this is the first tubular heater in the industry with three-phase capability. The three coil, three-phase heater will offer a lower amperage solution while delivering the full power required in a compact heater package.

Previously three separate heaters would have been required to do the same job; therefore Watlow's new multicoil heater capabilities save money.

Watlow has the capability to put up to two coils in a 0.375 or 0.430 diameter heater and up to three coils in a 0.475 or 0.490 diameter heater. Any one or more of these coils can be a resistance wire or a thermocouple. The bending formations are virtually limitless; while mounting options are similar to other Watlow tubular heaters. The three-phase multicoil heaters can be single ended with three leads for three-phase wye hook up. Watlow recommends using an epoxy moisture seal or silicone-based seal.

Watlow's multicoil heaters are available in all standard materials such as Incoloy®, 304 and 316 stainless steel, and can be formed into almost any configuration. Our five thermocouple and/or coil options for multicoil tubular configurations will meet most requirements; however, we are always interested in discussing the use of different materials or changing the number of coils and thermocouples.

#### Features and Benefits

- **Three-phase capability** results in one element versus three, lower amperage, reduced installation time and lower overall cost.
- **Internal thermocouple** allows responsive and accurate, internal, high-limit sensing and reduced assembly costs.
- **Single ended** allows for mounting in a ½ inch NPT or ¾ inch NPT fitting with three-phase capability.
- **Multiple coil options** reduce inventory by allowing dual voltage capability.
- **Versatile forming capabilities** can be formed into virtually any configuration.
- **Internal construction** allows space savings because drilling and tapping of flange is unnecessary; plus, the interior thermocouple eliminates contamination buildup around the external sensing tip, reducing the possibility of false readings.

#### Applications

- Foodservice
- Process
- Medical
- Milled groove
- Plastics
- Plating
- Oven heating
- Semiconductor

## Tubular and Process Assemblies

### WATROD Heating Elements Multicoil Single- or Double-Ended Elements

Continued

#### Options

##### Option A

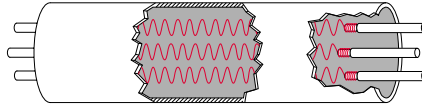

3-phase tubular, 0.475 and 0.490 inch diameter.

##### Option B

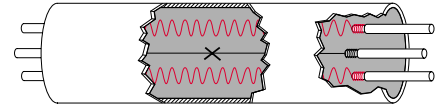

1-phase tubular with two resistance wires and one thermocouple, 0.475 and 0.490 inch diameter.

##### Option C

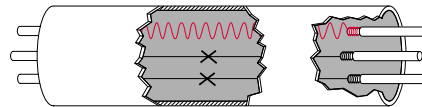

1-phase tubular with one resistance wire and two thermocouples, 0.475 and 0.490 inch diameter.

##### Option D

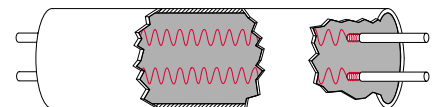

1-phase tubular with three different one phase circuits, 0.475 and 0.490 inch diameter.

##### Option E

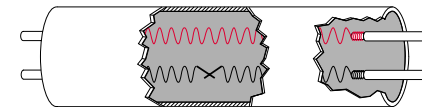

1-phase tubular with two resistance coils, 0.375, 0.430, 0.475 and 0.490 inch diameter.

##### Option F

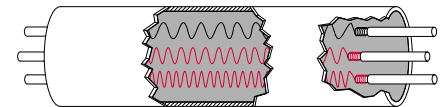

1-phase tubular with one resistance coil and one thermocouple, 0.375, 0.430, 0.475 and 0.490 inch diameter.

#### Specifications

**Termination style** is currently limited to lead wires 392°F (200°C) Sil-A-Blend™ or 482°F (250°C) GGS.

**Moisture seals** are required, options include:

- Standard epoxy with temperature rating to 266°F (130°C). Typical applications include water/oil immersion.
- Lavacone with temperature rating to 300°F (148.9°C). Typical application includes air heating.
- High-temp ceramic rated to 2800°F (1537.8°C).
- Consult factory for other moisture seal options.
- ULTRAGARD with temperature rating to 700°F (375°C).

**Mounting options** include:

- Mounting brackets
- Locator washers
- Mounting collars
- Water-tight bulkheads

**Maximum trim length** is 237 inches (6020 mm). Heater designs with trim length greater than 120 inches (3048 mm) must be reviewed with factory.

**Sheath materials:** Incoloy®, 304 and 316 stainless steel, consult factory for other sheath material options.

**Internal thermocouple options:** Type K is used, consult factory for Type J thermocouple options.

**U.S. Patent Pending**

Sil-A-Blend™ is a trademark of Radix Wire Company.

# Tubular and Process Assemblies

## WATROD Heating Elements

### Specifications

#### Double-Ended

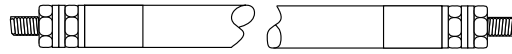

#### Single-Ended



<b>Applications</b>	Direct immersion Hot runner mold (manifold) Forced air Ovens Radiant Clamp-on	Vacuums Semiconductor	Platens Forced air Deicing antennas Plastic wrap cutting Seal bars
<b>Watt Density</b> W/in <sup>2</sup> (W/cm <sup>2</sup> )	Stock: Made-to-Order (M-t-O):	up to 60 (9.3) up to 120 (18.6)	Stock: M-t-O: up to 20 (3.1) up to 45 (6.9)
<b>Element Diameters and Surface Area per Linear</b>	<b>Dia.</b> <b>in<sup>2</sup></b>	<b>Dia. (mm)</b> <b>cm<sup>2</sup></b>	<b>Dia.</b> <b>in<sup>2</sup></b> <b>Dia. (mm)</b> <b>cm<sup>2</sup></b>
inch (mm)	0.210      0.660	(5.3)      (4.26)	0.375      1.178      (9.5)      (7.600)
and Surface Area per Linear	0.260      0.817	(6.6)      (5.27)	0.430      1.351      (10.9)      (8.717)
inch (cm)	0.315      0.990	(8.0)      (6.38)	0.475      1.492      (12.0)      (9.626)
Diameter Tolerance	0.332      1.043	(8.4)      (6.73)	0.490      1.539      (12.4)      (9.930)
± 0.005 inch (0.13 mm)	0.375      1.178	(9.5)      (7.60)	0.625      1.963      (15.9)      (12.665)
	0.430      1.351	(10.9)      (8.72)	
	0.475      1.492	(12.0)      (9.63)	
	0.490      1.539	(12.4)      (9.93)	
	0.625      1.963	(15.9)      (12.66)	
<b>Sheath Materials</b>	Stock:	Incoloy®      1600°F      (870°C) 316 stainless steel      1200°F      (650°C) Steel      750°F      (400°C) Copper      350°F      (175°C)	Stock:      Incoloy®      1200°F      (650°C)
<b>Maximum Operating Temperature</b>	M-t-O:	Inconel® 600      1800°F      (980°C) Incoloy®      1600°F      (870°C) 316 stainless steel      1200°F      (650°C) 304 stainless steel      1200°F      (650°C) Steel      750°F      (400°C) Copper      350°F      (175°C) Monel®      Consult Factory Titanium      Consult Factory	M-t-O:      Incoloy®      1600°F      (870°C) 316 stainless steel      1200°F      (650°C) 304 stainless steel      1200°F      (650°C) Steel      750°F      (400°C)
<b>Sheath Length By Diameter</b>	<b>Dia.</b> <b>Sheath Length</b>	<b>Dia.</b> <b>Sheath Length</b>	<b>Dia.</b> <b>Sheath Length</b> <b>Dia.</b> <b>Sheath Length</b>
inch (mm)	Stock:	Stock:	Stock:
	0.260      20 to 80	(6.6)      (510 to 2030)	0.375      15 to 40      (9.5)      (380 to 1015)
	0.315      12 to 100	(8.0)      (305 to 2540)	
	0.375      11 to 180	(9.5)      (275 to 4555)	
	0.430      15 to 120	(10.9)      (380 to 3050)	
	0.475      20 to 157	(12.0)      (510 to 3990)	
	M-t-O:	M-t-O:	M-t-O:
	0.210      9 to 130	(5.3)      (230 to 3300)	0.375      11 to 125      (9.5)      (280 to 3175)
	0.260      9 to 275	(6.6)      (230 to 6980)	0.430      11 to 106      (10.9)      (280 to 2690)
	0.315      9 to 270	(8.0)      (230 to 6850)	0.475      11 to 125      (12.0)      (280 to 3175)
	0.332      9 to 125	(8.5)      (230 to 3170)	0.490      11 to 125      (12.4)      (280 to 3175)
	0.375      11 to 325	(9.5)      (280 to 8255)	0.625      11 to 125      (15.9)      (280 to 3175)
	0.430      11 to 268	(10.9)      (280 to 6810)	
	0.475      11 to 275	(12.0)      (280 to 6985)	
	0.490      11 to 275	(12.4)      (280 to 6985)	
	0.625      11 to 275	(15.9)      (280 to 6985)	

# Tubular and Process Assemblies

## WATROD Heating Elements

### Specifications

#### Double-Ended

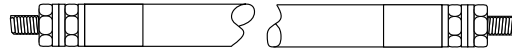

#### Single-Ended

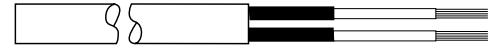

Minimum No-Heat Length inch (mm)	Sheath	No-Heat	Sheath	No-Heat	Sheath	No-Heat	Sheath	No-Heat
	Length	Length	Length	Length	Length	Length	Length	Length
	11 to 20	1	(280 to 510)	(25)	11 to 20	1½	(280 to 5100)	(38)
	21 to 50	1¼	(535 to 1270)	(32)	21 to 50	1¾	(533 to 1270)	(44)
	51 to 80	1½	(1295 to 2030)	(38)	51 to 80	2¼	(1295 to 2030)	(54)
	81 to 110	1¾	(2055 to 2795)	(42)	81 to 110	2½	(2055 to 2795)	(60)
	111 to 140	1¾	(2820 to 3555)	(44)	111 to 125	2¾	(2820 to 3175)	(67)
	141 to 170	2	(3580 to 4320)	(51)				
	171 to 200	2¼	(4345 to 5080)	(57)				
	201 & up	2½	(5105 & up)	(64)				
	<b>½ inch (13 mm) No-heat length on all blunt ends</b>							
Maximum Voltage/Amperage By Dia. inch (mm)	Dia.	Volts	Amps	Dia.	Volts	Amps		
	0.260 (6.6)	250V~(ac)	15	0.375 (9.5)	480V~(ac)	30		
	0.315 (8.0)	480V~(ac)	30	0.430 (10.9)	480V~(ac)	30		
	0.332 (8.5)	480V~(ac)	30	0.475 (12.0)	480V~(ac)	30		
	0.375 (9.5)	480V~(ac)	30	0.490 (12.4)	480V~(ac)	30		
	0.430 (10.9)	600V~(ac)	40	0.625 (15.9)	480V~(ac)	30		
	0.475 (12.0)	600V~(ac)	40					
	0.490 (12.4)	600V~(ac)	40					
	0.625 (15.9)	600V~(ac)	40					
Ohms Per Heated Inch By Dia. inch	Dia.	Minimum	Maximum	Dia.	Minimum	Maximum		
	0.210	0.100Ω	16Ω	0.375	0.200Ω	34Ω		
	0.260	0.080Ω	25Ω	0.430	0.200Ω	34Ω		
	0.315	0.050Ω	25Ω	0.475	0.200Ω	34Ω		
	0.332	0.050Ω	23Ω	0.490	0.200Ω	34Ω		
	0.375	0.020Ω	18Ω	0.625	0.200Ω	34Ω		
	0.430	0.025Ω	30Ω					
	0.475	0.030Ω	30Ω					
	0.490	0.030Ω	30Ω					
	0.625	0.030Ω	25Ω					
Terminations	Stock:	Threaded stud			Stock:	Flexible lead wires		
	M-t-O:	Threaded stud Screw lug (plate) Quick connect (spade) Flexible lead wires Rubber overmolds			M-t-O:	Flexible lead wires Rubber overmolds		
Seals	Stock:	Silicone resin	390°F	(200°C)	Stock:	Silicone resin	390°F	(200°C)
	M-t-O:	Ceramic base	2800°F	(1535°C)	M-t-O:	Silicone rubber (RTV)	500°F	(260°C)
		ULTRAGARD	700°F	(375°C)		ULTRAGARD	700°F	(375°C)
		Ceramic-to-metal	500°F	(260°C)		Silicone resin	392°F	(200°C)
		Silicone rubber (RTV)	500°F	(260°C)		Epoxy resin	266/350°F	(130/177°C)
		Silicone resin	392°F	(200°C)				
		Epoxy resin	266/350°F	(130/177°C)				
Mounting Options	Threaded bulkheads Mounting brackets Locator washers Mounting collars				Threaded bulkhead Locator washers Mounting collars			
Surface Finish Options	Belt polishing			Bright Anneal	Belt polishing			Bright Anneal
	Passivation				Passivation			
Agency Recognition	UL® Component to 480V~(ac) (file # E52951/E56488)				UL® Component to 240V~(ac) (file # E52951)			
	CSA Component to 600V~(ac) (file # 31388)				CSA Component to 240V~(ac) (file # 31388) ①			

WATROD

① Not applicable to 0.375 inch diameter single-ended WATROD

# Tubular and Process Assemblies

## WATROD Heating Elements

### Options

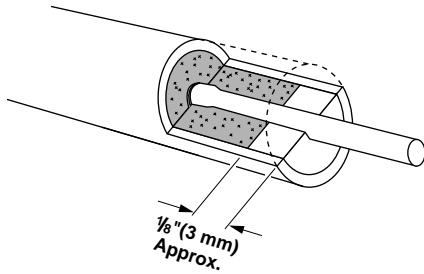

### Moisture Resistant Seals

WATROD's MgO insulating material is hygroscopic. To prevent moisture contamination from entering the heater, an appropriate moisture seal must be used. Choosing the correct seal is important to the life and performance of the heater. Be sure

the maximum continuous use temperature is not exceeded at the seal location. Most end seals are applied with a small cavity in the end of the heater. The seal will also help prevent arcing at the terminal ends.

### End Seal Options

End Seal	Code Number	Color	Seal Depth	UL® Recognition	Max. Cont. Use Temperature	Typical or General Usage/Application
Standard Epoxy	<b>EC</b>	Cream	3/16"	Yes	266°F (130°C)	General purpose for moisture resistance
Intermediate Epoxy	<b>EB</b>	Blue	3/16"	Yes	350°F (177°C)	Intermediate temp. rating for moisture resistance
High-Temp. Epoxy	<b>HTE</b>	Amber	3/16"	No	450°F (232°C)	Higher temp. rating for moisture resistance
Silicone Resin	<b>SR</b>	Clear	1/8"	Yes	392°F (200°C)	General usage on tubular products
Silicone Fluid	<b>SF</b>	Clear	N/A	No	392°F (200°C)	Moisture resistance of the MgO, or High-Temp. ceramic seal (storage only)
Lavacone	<b>LC</b>	Dark Brown	3/16"	Yes	392°F (200°C)	Porous seal for the FIREBAR
Silicone Rubber RTV	<b>RTV</b>	Red-Orange	3/16"	Yes	500°F (260°C)	General usage on FIREBAR applications
ULTRAGARD	<b>UG</b>	Clear	3/16"	Yes	700°F (350°C)	High temp. around seal area and for vacuum applications
High-Temp. Ceramic	<b>HTC</b>	White	3/16"	No	2800°F (1538°C)	Very high temperature applications

### Ceramic-to-Metal End Seal

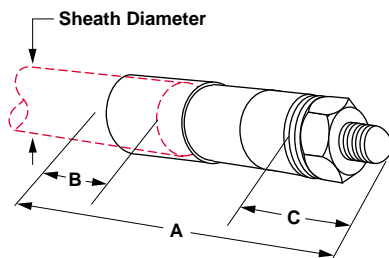

Sheath Diameter	A	B	C	Thread Size
inch (mm)	inch (mm)	inch (mm)	inch (mm)	
0.260 (6.6)	1 11/16 (40)	1/2 (13)	1 3/32 (10)	#8-32
0.315 (8)	1 7/8 (43)	1/2 (13)	1 3/32 (10)	#10-32
0.430 (10.9)	2 1/8 (54)	1/2 (13)	2 7/32 (10)	#1/4-28

To order specify, **ceramic-to-metal end seal**.

Ceramic-to-metal end seals with threaded stud terminations provide an air-tight seal for continuous terminal temperatures up to 500°F

(260°C). Watlow does not recommend this seal if terminations are exposed to temperatures exceeding 500°F (260°C).

### External Finishes

#### Belt Polishing

Belt polishing sands the oxidized sheath to a bright finish. This finish is available only on alloy sheath materials.

To order, specify **belt polishing**.

#### Bright Annealing

A process that produces a smooth, metallic finish. It is a special annealed finish created in a non-oxidizing atmosphere. This finish is popular in the pharmaceutical and food and beverage markets.

To order, specify **bright annealing**.

#### Passivation

During the manufacturing process, particles of iron or tool steel may become embedded in the stainless steel or alloy sheath. If not removed, these particles may corrode, produce rust spots and/or contaminate the process. For critical sheath applications, passivation will remove free iron from the sheath.

To order, specify **passivation**.

# Tubular and Process Assemblies

## WATROD Heating Elements

### WATROD Terminations

Double-ended WATROD elements are available with a variety of terminations. Single-ended WATROD elements are available with only flexible lead wires.

The following table and illustrations detail the terminations available with double- or single-ended WATRODs—for each available sheath diameter.

Standard flexible lead wires are 12 inches (305 mm), Sil-A-Blend™ 390°F (200°C) unless otherwise

specified. Insulation options include TGGT (480°F/250°C) plus other temperature ratings. Consult factory for availability.

Overmolds are available for flexible lead wires only. Available in silicone rubber (390°F/200°C), neoprene (212°F/90°C) and other materials. Consult factory for details.

WATROD Element	Sheath Diameter		Threaded Stud <sup>①</sup>	Screw Lug (Plate)				Quick Connect (Spade)			Flexible Lead Wires	Lead Wire Overmolds
	inch	(mm)		A	B	C	D	E	F	G		
Double-Ended	0.260	(6.6)	#6-32	Yes	Yes	Yes	Yes	Yes	Yes	Yes	Yes	Yes
	0.315	(8.0)	#10-32	Yes	Yes	Yes	Yes	Yes	Yes	Yes	Yes	Yes
	0.335	(8.5)	#10-32	Yes	Yes	Yes	Yes	Yes	Yes	Yes	Yes	No
	0.375	(9.5)	#10-32	Yes	Yes	Yes	Yes	Yes	Yes	Yes	Yes	No
	0.430	(10.9)	#10-32	Yes	Yes	Yes	Yes	Yes	Yes	Yes	Yes	Yes
	0.475	(12.0)	#10-32	Yes	Yes	Yes	Yes	Yes	Yes	Yes	Yes	Yes
	0.490	(12.4)	#10-32	Yes	Yes	Yes	Yes	Yes	Yes	Yes	Yes	No
Single-Ended	0.625	(15.9)	#10-32	Yes	Yes	Yes	Yes	Yes	Yes	Yes	Yes	No
	0.375	(9.5)	No	No	No	No	No	No	No	No	Yes	No
	0.430	(10.9)	No	No	No	No	No	No	No	No	Yes	Yes
	0.475	(12.0)	No	No	No	No	No	No	No	No	Yes	Yes
	0.490	(12.4)	No	No	No	No	No	No	No	No	Yes	No
	0.625	(15.9)	No	No	No	No	No	No	No	No	Yes	Yes

WATROD

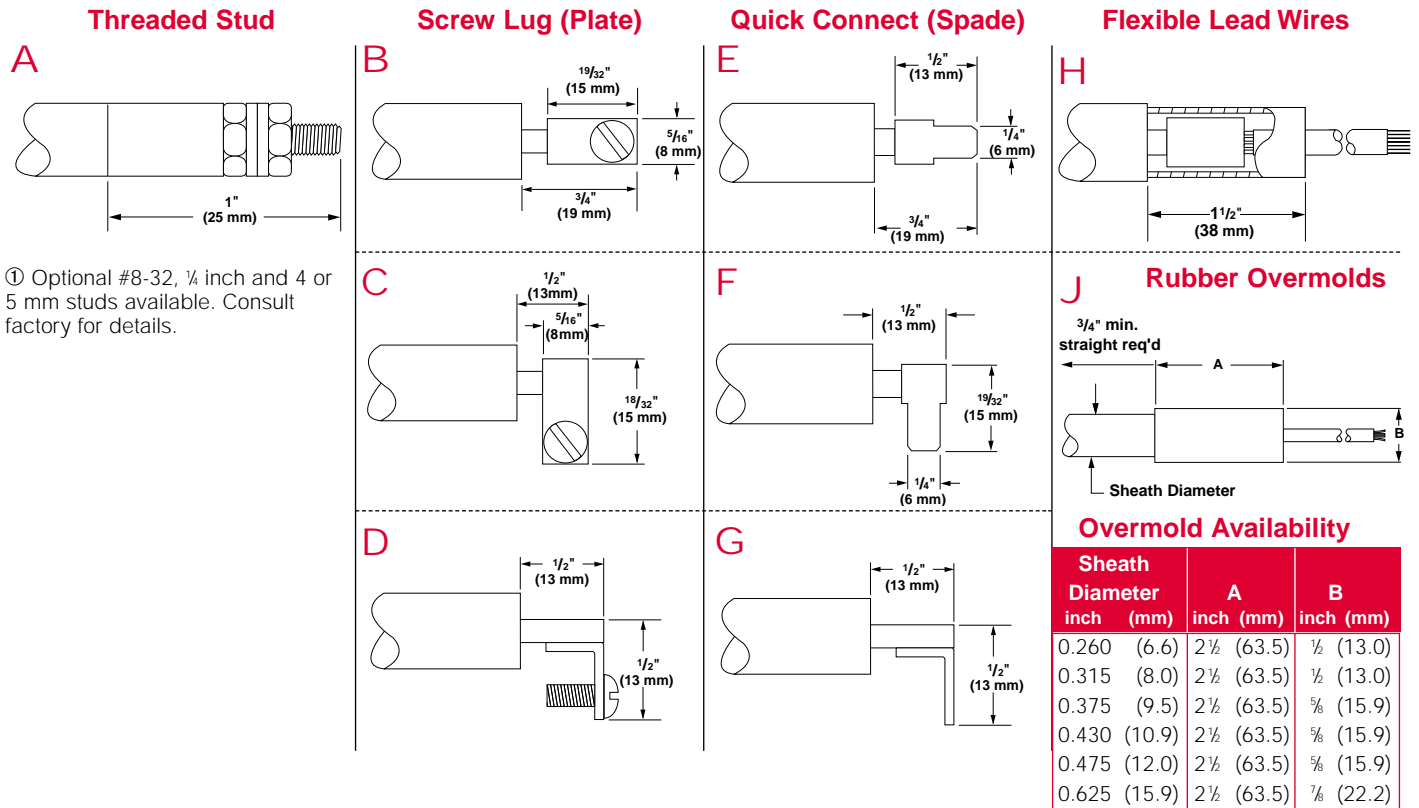

# Tubular and Process Assemblies

## WATROD Heating Elements

### Double-Ended WATROD Bend Formations

Double-ended WATROD heating elements can be formed into spirals, compounds, multi-axis and multi-planes from 36 common bend configurations. Custom bending with tighter tolerances can be made to meet specific application needs. Formation is limited by the minimum bend radius (R) and the straight length (F) required beyond the bend. In order to locate the end of a heated length within a bend, the radius must be three inches (76 mm) or larger. Additionally, overall length tolerance (T) must be included in one or more of the straight lengths.

Minimum radius for various sheath diameters and lengths are shown in the *Bend Formations* chart below. Illustrated on **pages 282 to 286** are the 36 common bend configurations available on both stock and made-to-order WATROD heating elements.

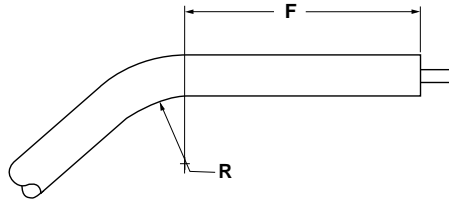

### Single-Ended WATROD Bend Formations

Watlow does not recommend field bending single-ended WATROD elements. Formation is limited by the minimum radius of a bend (R)

and the straight length (F) beyond the bend. The radius must be three inches (75 mm) or more for the heated length's end to be inside a bend.

Additionally, the overall length tolerance (T) must be provided for in one or more of the specified lengths.

The four common bend configurations available for standard and made-to-order single-ended WATROD elements are Figures 1, 6, 22 and 28.

To order a common bend formation, specify the **bend figure number**, dimensions and critical tolerances.

WATROD Length Tolerance (T)			
Sheath Length		Length Tolerance	
inch	(mm)	inch	(mm)
11-50	(280-1270)	±1/8	(±3)
51-110	(1295-2795)	±3/16	(±5)
111-170	(2820-4320)	±1/4	(±6)
171-200	(4345-5080)	±3/8	(±10)
201 & up	(5105 & up)	±1/2	(±13)

WATROD Minimum Radius							
Sheath Diameter		Field Bend R <sup>①</sup>		Factory R <sup>①</sup>		F <sup>②</sup> Dimension	
inch	(mm)	inch	(mm)	inch	(mm)	inch	(mm)
0.260	(6.6)	3/8	(19)	3/8	(10)	1/2	(13)
0.315	(8.0)	3/8	(19)	1/2	(13)	1/2	(13)
0.335	(8.5)	1	(25)	1/2	(13)	1	(25)
0.375	(9.5)	1	(25)	1/2	(13)	1/2	(13)
0.430	(10.9)	1	(25)	1/2	(13)	3/4	(19)
0.475	(12.0)	1	(25)	3/8	(16)	1	(25)
0.490	(12.5)	1	(25)	3/8	(16)	1	(25)
0.625	(15.9)	1 1/2	(38)	3/4	(19)	1 1/2	(38)

## Bend Formations

- ① R is the inside radius of a bend.
- ② F is the distance from the sheath's end to the start of the first bend.

Figure 1

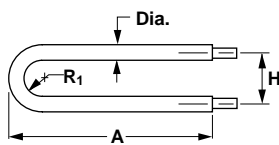

$$SL = 2A + 1.14R_1 - 0.43 \text{ Dia.}$$

(For pricing, use 1 bend)

Figure 2

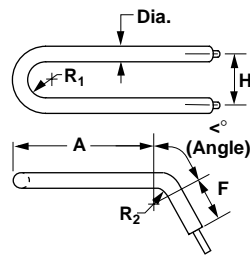

$$SL = 2A + 2F + 1.14R_1 + 0.0175 (\theta^\circ) (2R_2 + \text{Dia.}) - 0.43 \text{ Dia.}$$

(For pricing, use 3 bends)

Figure 3

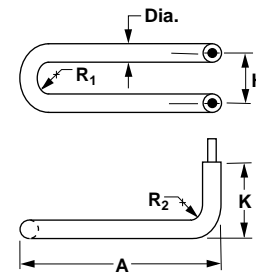

$$SL = 2K - 0.86R_2 - 2.86 \text{ Dia.} + 2A + 1.14R_1$$

(For pricing, use 3 bends)

# Tubular and Process Assemblies

## WATROD Heating Elements

**Figure 4**

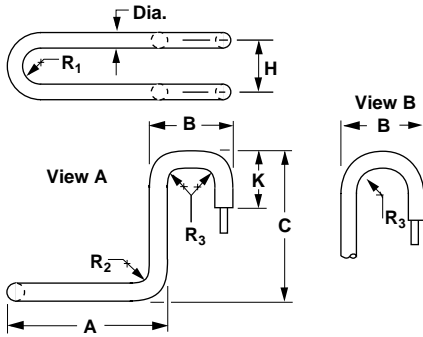

View A:  $SL = 2K - 1.72R_3 - 7.72 \text{ Dia.} + 2C - 0.86R_2 + 2A + 1.14R_1$   
 View B:  $SL = 2K - 2.28R_3 - 3.72 \text{ Dia.} + 2C - 0.86R_2 + 2A + 1.14R_1$   
 (For pricing, use 5 bends)

**Figure 5**

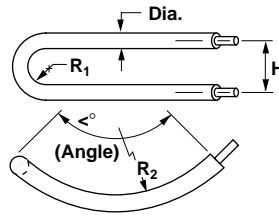

$SL = 0.0175(\angle) (2R_2 + \text{Dia.}) + 1.14R_1 + 0.43 \text{ Dia.}$   
 (For pricing, use 3 bends)

**Figure 6**

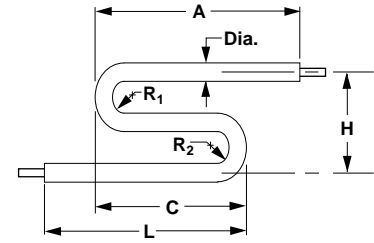

$SL = L + 1.14R_2 - 0.86 \text{ Dia.} + C + 1.14R_1 + A$   
 (For pricing, use 2 bends)

WATROD

**Figure 7**

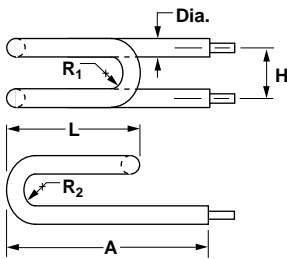

$SL = 2A + 2.28R_2 - 1.29 \text{ Dia.} + 2L + 1.14R_1$   
 (For pricing, use 3 bends)

**Figure 8**

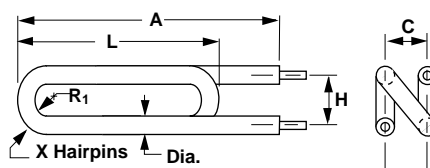

X = number of outside hairpins  
 $SL = 2A + 3.42R_1 - 1.29 \text{ Dia.} + 2L$   
 (For pricing, use 5 bends)

**Figure 9**

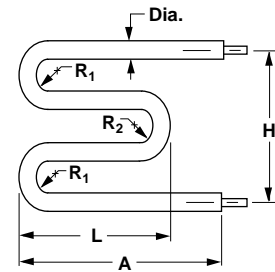

$SL = 2A + 2.28R_1 - 1.29 \text{ Dia.} + 2L + 1.14R_2$   
 (For pricing, use 3 bends)

**Figure 10**

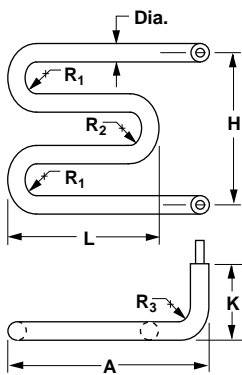

$SL = 2K - 0.86R_3 - 3.72 \text{ Dia.} + 2A + 2L + 2.28R_1 + 1.14R_2$   
 (For pricing, use 5 bends)

**Figure 11**

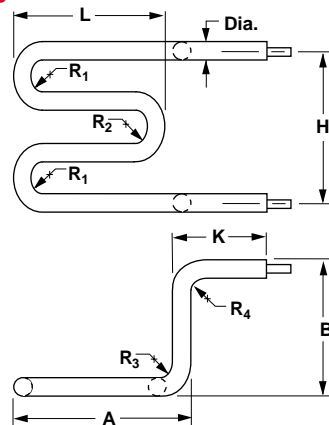

$SL = 2K - 0.86R_3 - 0.86R_4 - 6.15 \text{ Dia.} + 2B + 2A + 2L + 2.28R_1 + 1.14R_2$   
 (For pricing, use 7 bends)

**Figure 12**

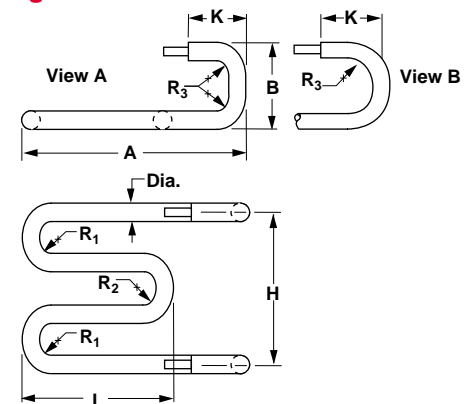

View A:  $SL = 2K + 2B + 2A + 2L + 2.28R_1 + 1.14R_2 - 1.72R_3 - 6.15 \text{ Dia.}$   
 View B:  $SL = 2K + 2A + 2L + 2.28R_1 + 1.14R_2 - 2.28R_3 - 2.15 \text{ Dia.}$   
 (For pricing, use 5 bends)

# Tubular and Process Assemblies

## WATROD Heating Elements

**Figure 13**

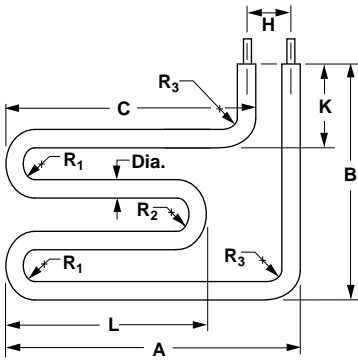

$$SL = 2B + 2A + 2L - 6.717 \text{ Dia.} - 1.717R_1 - H - 0.858R_2 - 0.858R_3$$

(For pricing, use 5 bends)

**Figure 14**

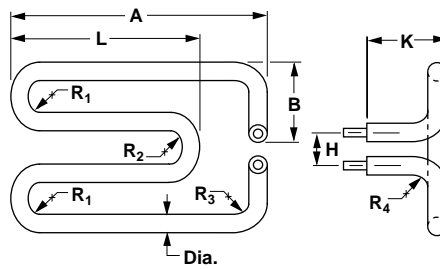

$$SL + 2K + 2A + 2L + 2.28R_1 + 1.14R_2 + 2B - 6.15 \text{ Dia.} - 0.86R_3 + 0.86R_4$$

(For pricing use 7 bends)

**Figure 15**

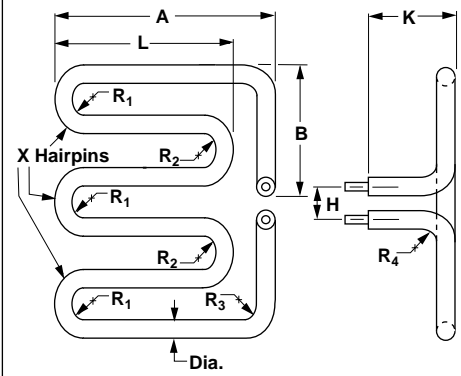

X = number of outside hairpins

$$SL = 2K + 2A + 2K(X - 1) + 2B - 0.86R_3 - 0.86R_4 + 1.14R_1(X) + 1.14R_2(X - 1) - 4.86 \text{ Dia.} - (2X - 1) 0.43 \text{ Dia.}$$

(For pricing, use 9 bends if X = 3 hairpins)

**Figure 16**

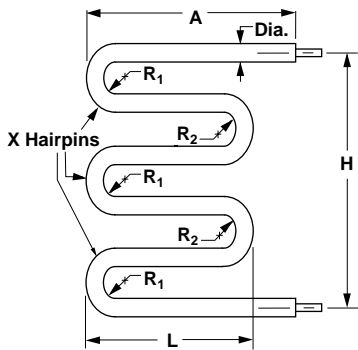

X = number of outside hairpins

$$SL = 2A + 0.43 \text{ Dia.} (1 - 2X) + 2L(X - 1) + 1.14R_1 + 1.14R_2(X - 1)$$

(For pricing, use 5 bends if X = 3 hairpins)

**Figure 17**

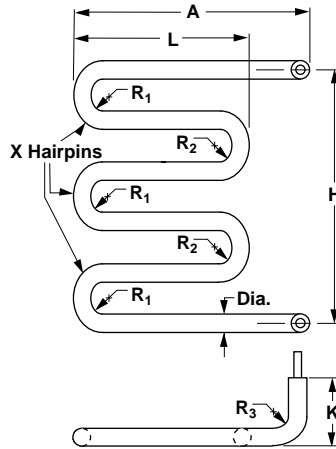

X = number of outside hairpins

$$SL = 1.14R_2 X - 0.88 \text{ Dia.} X - 1.14R_2 - 2 \text{ Dia.} + 1.14R_1 X - 0.86R_3 + 2L X - 2L + 2A + 2K$$

(For pricing, use 7 bends if X = 3 hairpins)

**Figure 18**

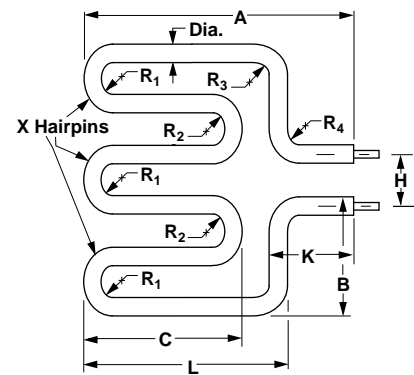

X = number of outside hairpins

$$SL = 2L + 2K + 2B + 2C(X - 1) - 0.86R_3 - 0.86R_4 - 4.86 \text{ Dia.} + 1.14R_1(X) + 1.14R_2(X - 1) - (2X - 1) 0.43 \text{ Dia.}$$

(For pricing, use 9 bends if X = 3 hairpins)

# Tubular and Process Assemblies

## WATROD Heating Elements

**Figure 19**

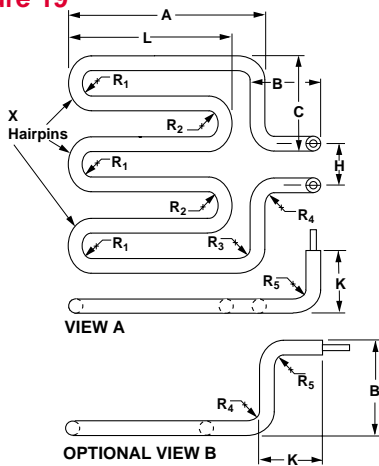

X = number of outside hairpins  
 View A and B:  $SL = 2K + 2A + 2B + 2C + 2L(X - 1) + 1.14R_1(X) + 1.14R_2(X - 1) - 0.86R_3 - 0.86R_4 - 0.86R_5 - 7.29 \text{ Dia.} - (2X - 1) 0.43 \text{ Dia.}$   
 (For pricing, use 11 bends if X = 3 hairpins)

**Figure 20**

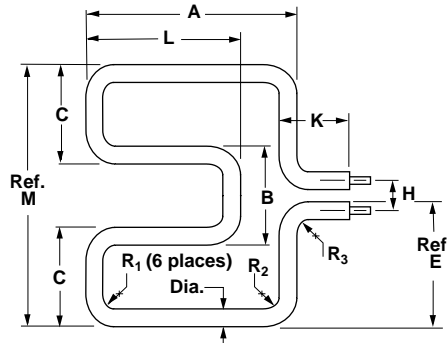

$SL = 2K + 2C + B + 2A + 2L - 2.58R_1 - 0.86R_2 - 0.86R_3 - 12.15 \text{ Dia.}$   
 (For pricing, use 10 bends)

**Figure 21**

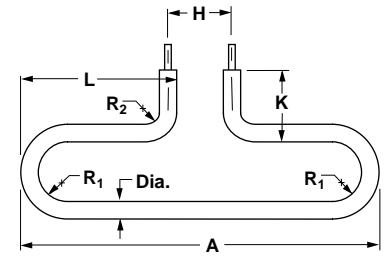

$SL = 2A + 2K - H - 2.28R_1 - 0.86R_2 - 3.29 \text{ Dia.}$   
 (For pricing, use 4 bends)

WATROD

**Figure 22**

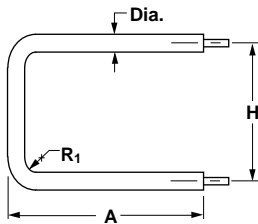

$SL = 2A - 0.86R_1 - 1.43 \text{ Dia.} + H$   
 (For pricing, use 2 bends)

**Figure 23**

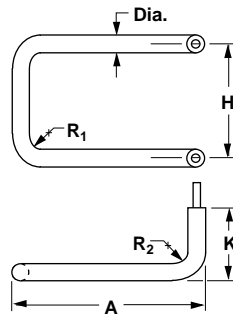

$SL = 2K - 0.86R_2 - 3.86 \text{ Dia.} + 2A - 0.86R_1 + H$   
 (For pricing, use 4 bends)

**Figure 24**

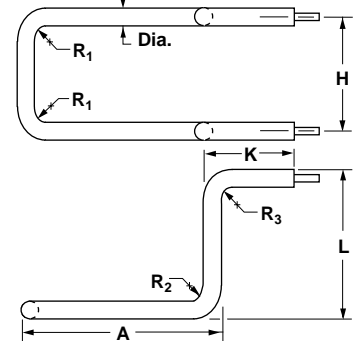

$SL = 2K + 2L + H - 0.86R_1 - 0.86R_2 - 0.86R_3 - 7.29 \text{ Dia.}$   
 (For pricing, use 6 bends)

**Figure 25**

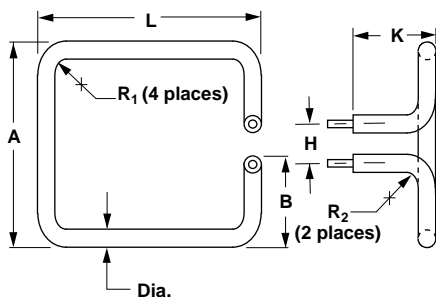

$SL = 2K + 2A + 2L - H - 1.72R_1 - 0.86R_2 - 6.92 \text{ Dia.}$   
 (For pricing, use 6 bends)

**Figure 26**

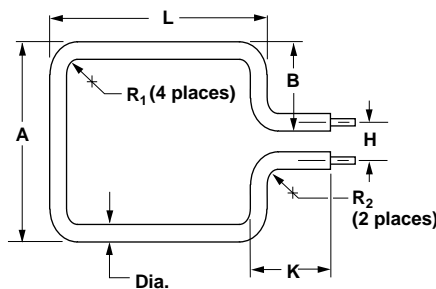

$SL = 2K + 2A + 2L - H - 1.72R_1 - 0.86R_2 - 6.29 \text{ Dia.}$   
 (For pricing, use 6 bends)

**Figure 27**

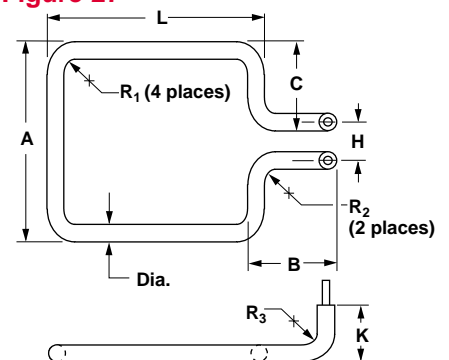

$SL = 2K + 2A + 2L + 2B - H - 1.72R_1 - 1.72R_2 - 8.72 \text{ Dia.}$   
 (For pricing, use 8 bends)

# Tubular and Process Assemblies

## WATROD Heating Elements

**Figure 28**

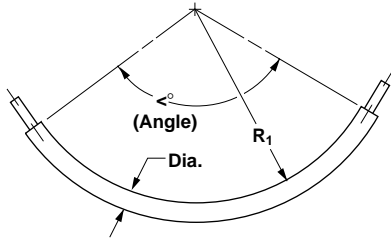

$$SL = 0.0175 <^\circ (R_1 + 0.5 \text{ Dia.})$$

(For pricing, use 1 bend)

**Figure 29**

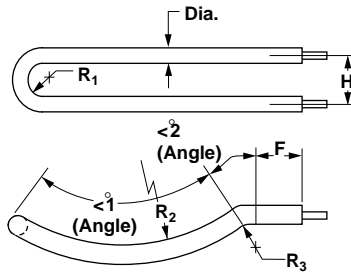

$$SL = 0.0175 <^\circ 1 (2R_2 + \text{Dia.}) + 2F + 1.14R_1 + 0.0175 <^\circ 2 (2R_3 + \text{Dia.}) - 0.43 \text{ Dia.}$$

(For pricing, use 5 bends)

**Figure 30**

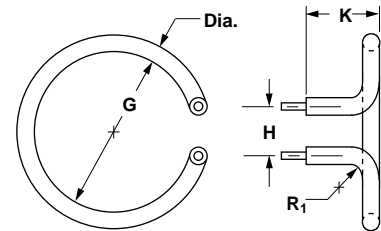

$$SL = (G + \text{Dia.}) 3.14 + 1.14R_1 + 2K + 3.28 \text{ Dia.} - H$$

(For pricing, use 4 bends)

**Figure 31**

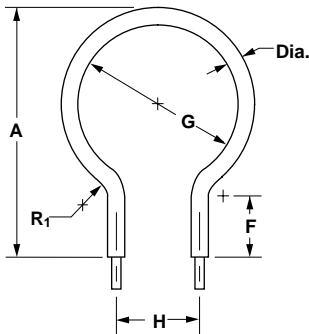

$$SL = (G + \text{Dia.}) 3.14 + 1.14R_1 + 2F + 3.71 \text{ Dia.} - H$$

(For pricing, use 4 bends)

**Figure 32**

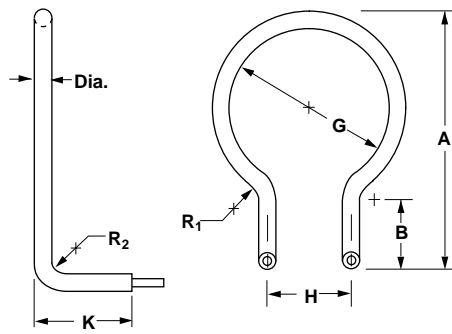

$$SL = (G + \text{Dia.}) 3.14 + 1.14R_1 + 2B + 1.14R_2 + 2K + 3.28 \text{ Dia.} - H$$

(For pricing, use 6 bends)

**Figure 33**

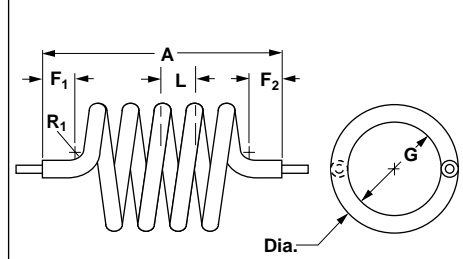

$$SL = [(G + \text{Dia.}) (3.14) (\text{Number of } 360^\circ\text{'s}) + F_1 + F_2]$$

(For pricing, consult factory)

**Figure 34**

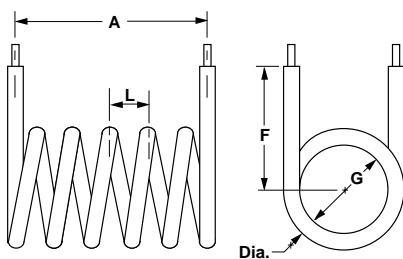

$$SL = [(G + \text{Dia.}) (3.14) (\text{Number of } 360^\circ\text{'s}) + 2F]$$

(For pricing, consult factory)

**Figure 35**

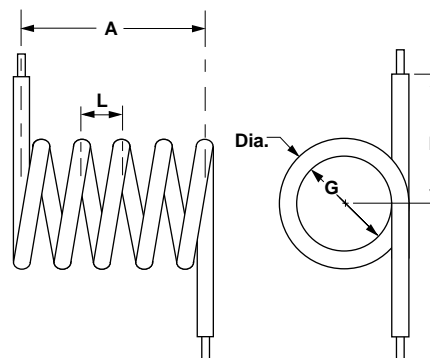

$$SL = [(G + \text{Dia.}) (3.14) (\text{Number of } 360^\circ\text{'s}) + 2F]$$

(For pricing, consult factory)

**Figure 36**

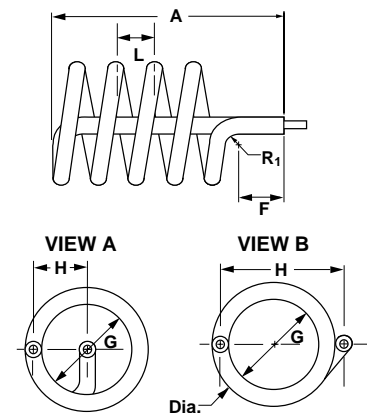

$$SL = [(G + \text{Dia.}) (3.14) (\text{Number of } 360^\circ\text{'s}) + (G + 2) + A + F]$$

(For pricing, consult factory)

## Tubular and Process Assemblies

### WATROD Heating Elements

#### Mounting Methods Brackets

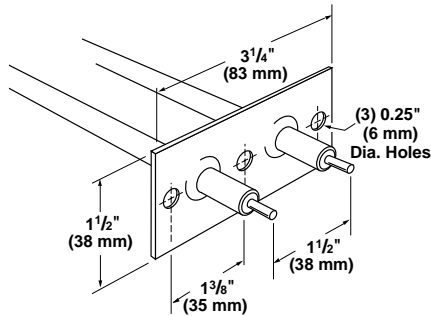

A 0.065 inch (1.7 mm) thick stainless steel bracket provides element mounting in non-pressurized applications. Attached to the heater sheath, these brackets are not suited for liquid-tight mountings. The bracket is located 1/2 inch (13 mm) from the sheath's end, unless otherwise specified. To order, specify **mounting bracket**.

#### Single Leg Bracket

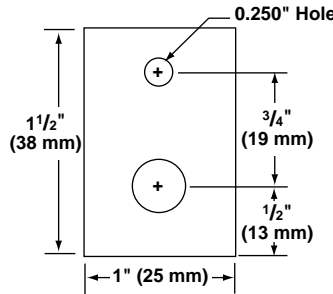

A 1 1/2 inch (38 mm) x 1 inch (25 mm) wide x 16 gauge stainless steel bracket with one element hole and one mounting hole 1/2 inch from end. To order, specify **single leg bracket**.

#### Locator Washers

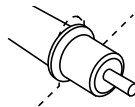

Stainless steel locator washers retain the heated area of the sheath

in the work zone, while allowing for expansion and contraction during cycling.

To order, specify **locator washer**, along with dimension from the heater's end.

#### Mounting Collars

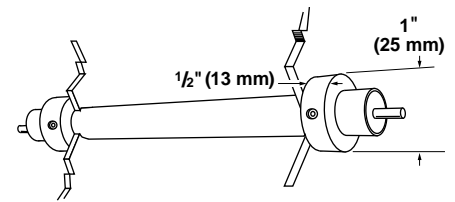

Plated steel mounting collars secure the heater sheath with set screws to serve as adjustable stops for through-the-wall mounting. Collars are shipped in bulk. To order, specify **mounting collars**.

#### Threaded Bulkheads

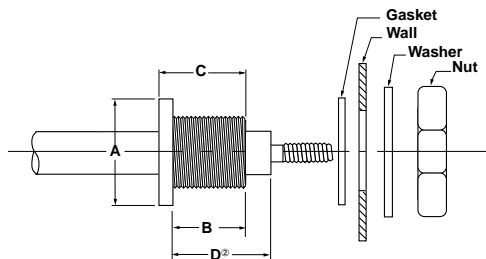

A threaded bushing with flange on the heater sheath provides rigid, leak-proof mounting through the walls of tanks. A gasket, plated steel washer and hex nut are included. The threaded end of the bushing is flush with the sheath's end unless otherwise specified. Threaded bulkheads are available in brass, steel or stainless steel as indicated in the table. To order, specify **threaded bulkheads** and the specifications from the table.

#### Threaded Bulkhead Specifications

Element Diameter inch (mm)	Material	Thread Size	A <sup>①</sup> Flange Size/Style inch (mm)	B Threaded Length inch (mm)	C Overall Length inch (mm)
0.260 (6.6)	Brass	1/2 - 20 UNF	3/4 Round (19)	5/8 (15.9)	3/4 (19)
0.260 (6.6)	Steel	1/2 - 20 UNF	3/4 Hex (19)	5/8 (15.9)	3/4 (19)
0.260 (6.6)	S. Steel	1/2 - 20 UNF	3/4 Round (19)	5/8 (15.9)	3/4 (19)
0.315 (8.0)	Brass	1/2 - 20 UNF	3/4 Round (19)	5/8 (15.9)	3/4 (19)
0.315 (8.0)	Steel	1/2 - 20 UNF	3/4 Hex (19)	3/4 (19.0)	15/16 (24)
0.315 (8.0)	S. Steel	1/2 - 20 UNF	3/4 Round (19)	3/4 (19.0)	27/32 (21)
0.375 (9.5)	Brass	1/2 - 20 UNF	3/4 Round (19)	5/8 (15.9)	3/4 (19)
0.375 (9.5)	Steel	1/2 - 20 UNF	3/4 Hex (19)	3/4 (19.0)	15/16 (24)
0.375 (9.5)	S. Steel	1/2 - 20 UNF	3/4 Round (19)	3/4 (19.0)	27/32 (21)
0.430 (10.9)	Brass	5/8 - 18 UNF	7/8 Hex (22)	3/4 (19.0)	15/16 (24)
0.430 (10.9)	Steel	5/8 - 18 UNF	7/8 Round (22)	3/4 (19.0)	15/16 (24)
0.430 (10.9)	S. Steel	5/8 - 18 UNF	1 Round (25)	3/4 (19.0)	15/16 (24)
0.475 (12.1)	Brass	5/8 - 18 UNF	7/8 Round (22)	3/4 (19.0)	15/16 (24)
0.475 (12.1)	Steel	5/8 - 18 UNF	1 Round (25)	1 (25.0)	1 1/8 (29)
0.475 (12.1)	S. Steel	5/8 - 18 UNF	1 Round (25)	3/4 (19.0)	15/16 (24)
0.490 (12.4)	Brass	3/4 - 16 UNF	1 Round (25)	3/4 (19.0)	1 (25)
0.490 (12.4)	Steel	3/4 - 16 UNF	1 Hex (25)	3/4 (19.0)	1 (25)
0.490 (12.4)	S. Steel	3/4 - 16 UNF	1 Round (25)	3/4 (19.0)	1 (25)
0.625 (15.9)	S. Steel	1/2 - 14 UNF	1 Round (25)	3/4 (19.0)	1 (25)

① Designates the dimension across flats for hex flange style and outside diameter for round flange style.

② Equal to "B" Dimension unless otherwise specified.

# Tubular and Process Assemblies

## WATROD Heating Elements

### **Tubular PLUS Program**

Watlow's Tubular PLUS Program is an innovative stocking program that allows formed tubular heaters to be shipped in three to six days, instead of the four to six weeks it takes most manufacturers.

The Tubular PLUS Program allows customers to order the desired heated length, cold length, diameter, heater wattage, voltage, formation and termination option.

By utilizing stocked 0.315 inch or 0.430 inch diameter Incoloy® elements, an appropriate heater is selected from stock and modified to fit the physical description of the required heater. The heater is annealed to remove moisture and enable bending and then formed to the desired configuration. In most cases the only variation will be a slight difference in the heater wattage.

Because Watlow will now stock additional tubular elements, the Tubular PLUS Program reduces downtime, lowers inventories and increases overall customer value.

### **Features and Benefits**

- **Availability of 0.315 inch and 0.430 inch diameters;** most commonly requested for formed tubular heaters.
- **Cold ends from one inch to 18 inches** provide increased capabilities for short and long cold ends.

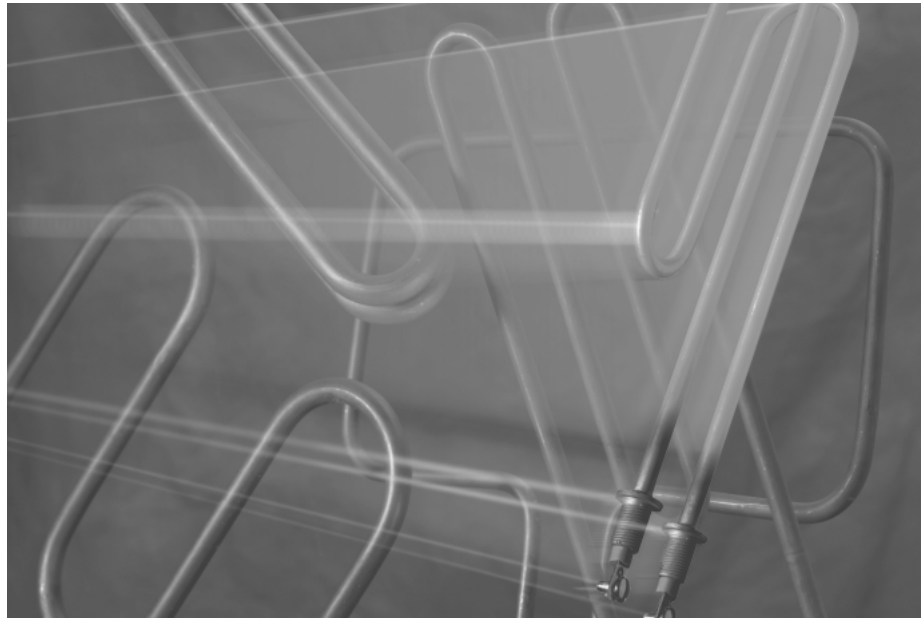

- **Minimum heated lengths to four inches** provide shorter heated lengths than currently available using conventional tubulars.
- **Incoloy® 800 sheath material** provides the highest quality sheath material for immersion and air applications.

### **PLUS One**

- **Quick delivery: three to six days vs. four to six weeks** results in reduced downtime, lower inventories and increased overall customer value.

### **PLUS Two**

- **Precise location of cold ends and heated lengths** assists in applying heater and in proper bending, allows uniform heating in platens and puts the heat within the application.

### **PLUS Three**

- **Longer element lengths** allows use of one element to replace multiple elements and reduces terminations.

### **Applications**

- Plastics-Hot runner molds
- Packaging-Seal bars
- Semiconductor-CVD, PVD
- Cast-in heater platens

### **Options**

- Maximum heated length: 118 inches, up to 18 inches cold length on each side.
- All standard WATROD options are available.
- Selection of formation numbers 1, 3, 6, 7, 8, 11, 15, 16, 17, 18, 21, 22, 23, 25, 26, 30 and 31 (**pages 282-286**) offer quick delivery. Special formations will increase delivery times. Please consult factory for details.
- To determine if program is applicable to your needs, please contact your local Watlow sales representative.

Tubular PLUS Program Fax Back Order Form

Fax to 1-800-697-4329 or outside U.S. 1-573-221-3723

Customer Name	<input type="text"/>	Ordered By	<input type="text"/>
Customer Number	<input type="text"/>	Order Date	<input type="text"/>
Ship to Address:		Purchase Order #	<input type="text"/>
Street	<input type="text"/>	Delivery Date	<input type="text"/>
City	<input type="text"/>	Ship VIA	<input type="text"/>
State	<input type="text"/>	List/Net Price/Unit	<input type="text"/>
ZIP	<input type="text"/>	NSUC	<input type="text"/>

**Heater Description**

General Description

Heater Voltage	<input type="text"/>	Product Number	<input type="text"/>
Heater Wattage (watts) desired	<input type="text"/>	Quantity (1-12 pieces)	<input type="text"/>
Heater Wattage (watts) actual	<input type="text"/>	Termination Type: (A, B, C, D, E, F, G)	<input type="text"/>
Diameter: (0.315" or 0.430")	<input type="text"/>	Leadwire: (Sil-A-Blend™ - 200°C, TGGT - 250°C, Overmold)	<input type="text"/>
Material (Incoloy®)	<input type="text"/>	Leadwire length (Inches in dec.)	<input type="text"/>
Heated Length / inches (4" min.)	<input type="text"/>	Bulkhead Type: (Brass, Steel, St. Steel)	<input type="text"/>
Cold End 1 Length / inches (1" - 18")	<input type="text"/>	Mounting: (Brackets, Locator Washers, Mounting Collars)	<input type="text"/>
Cold End 2 Length / inches (1" - 18")	<input type="text"/>	Bracket / washer location: (From element end, 1/2" standard)	<input type="text"/>
Belt Polishing: (Yes, No)	<input type="text"/>		
Moisture Seal: (Epoxy, Ceramic, Ceramic to Metal, Silicone, None)	<input type="text"/>		

WATROD

Formation Details

Formation #: (1,3,6,7,8,11,15,16,17,18,21,22,23,25,26,30,31)

Dimensions:

A Dimension in inches	<input type="text"/>	X Number of outside hairpins	<input type="text"/>
B Dimension in inches	<input type="text"/>	R (In 1/8" increments)	<input type="text"/>
C Dimension in inches	<input type="text"/>	R1 (In 1/8" increments)	<input type="text"/>
G Dimension in inches	<input type="text"/>	R2 (In 1/8" increments)	<input type="text"/>
H Dimension in inches	<input type="text"/>	R3 (In 1/8" increments)	<input type="text"/>
L Dimension in inches	<input type="text"/>	R4 (In 1/8" increments)	<input type="text"/>
K Dimension in inches	<input type="text"/>		

# Tubular and Process Assemblies

F.O.B.: Hannibal, Missouri

## WATROD Heating Elements

### Double-Ended WATROD

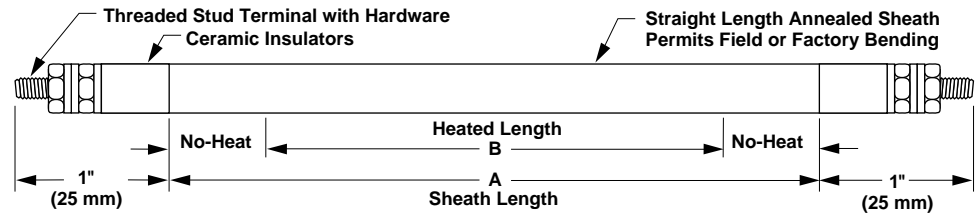

WATROD Description	Sheath A Dimension		Heated B Dimension		Watts	Code Number			Est. Net Weight	
	inch	(mm)	inch	(mm)		120V~(ac)	240V~(ac)	480V~(ac)	lbs	(kg)

#### Applications: Medium-Weight, Non-Circulating Oil, Heat-Transfer Oil

<b>15 W/in<sup>2</sup></b> <b>0.475" Dia.</b> <b>Steel</b> (2.3 W/cm <sup>2</sup> ) (12 mm)	29 $\frac{3}{8}$	(759)	22 $\frac{3}{8}$	(568)	500		<b>RGSS29R10S</b>		1.0	(0.5)
	38 $\frac{3}{8}$	(975)	29 $\frac{3}{8}$	(759)	667		<b>RGSS38G10S</b>	<b>RGSS38G11S</b>	1.3	(0.6)
	44 $\frac{3}{8}$	(1137)	37 $\frac{3}{8}$	(946)	833		<b>RGSS44G10S</b>	<b>RGSS44G11S</b>	1.7	(0.8)
	53 $\frac{3}{8}$	(1356)	44 $\frac{3}{8}$	(1137)	1000		<b>RGSS53G10S</b>	<b>RGSS53G11S</b>	1.9	(0.9)
	68 $\frac{3}{8}$	(1737)	59 $\frac{3}{8}$	(1514)	1333		<b>RGSS68G10S</b>	<b>RGSS68G11S</b>	2.1	(1.0)
	83 $\frac{3}{8}$	(2118)	74 $\frac{1}{2}$	(1892)	1667		<b>RGSS83G10S</b>	<b>RGSS83G11S</b>	2.5	(1.1)
	98 $\frac{3}{8}$	(2499)	89 $\frac{1}{2}$	(2273)	2000		<b>RGSS98G10S</b>	<b>RGSS98G11S</b>	3.0	(1.4)
	120 $\frac{3}{8}$	(3057)	111 $\frac{3}{8}$	(2842)	2500		<b>RGSS120G10S</b>	<b>RGSS120G11S</b>	3.9	(1.8)
142 $\frac{3}{8}$	(3629)	134 $\frac{1}{4}$	(3410)	3000		<b>RGSS142R10S</b>	<b>RGSS142R11S</b>	4.1	(1.9)	

#### Application: Air Heating

<b>20 W/in<sup>2</sup></b> <b>0.430" Dia.</b> <b>Incoloy®</b> (3.1 W/cm <sup>2</sup> ) (10.9 mm)	48 $\frac{3}{8}$	(1238)	38 $\frac{3}{8}$	(984)	1000		<b>RCN48N10S</b>	<b>RCN48N11S</b>	1.0	(0.5)
	58 $\frac{3}{8}$	(1492)	48 $\frac{3}{8}$	(1238)	1250		<b>RCN58N10S</b>	<b>RCN58N11S</b>	1.1	(0.5)
	73 $\frac{3}{8}$	(1873)	63 $\frac{3}{8}$	(1619)	1667			<b>RCN73N11S</b>	1.4	(0.7)
	91 $\frac{3}{8}$	(2330)	81 $\frac{3}{8}$	(2076)	2083			<b>RCN91N11S</b>	1.7	(0.8)

#### Applications: Caustic Solutions, Air Heating

<b>23 W/in<sup>2</sup></b> <b>Incoloy®</b> <b>0.315" Dia.</b> (3.6 W/cm <sup>2</sup> ) (8 mm)	29	(737)	22	(559)	500	<b>RBN291S</b>			0.4	(0.2)	
	40	(1016)	33	(839)	750	<b>RBN401S</b>			0.5	(0.3)	
	51	(1296)	44	(1118)	1000	<b>RBN511S</b>			0.7	(0.4)	
<b>23 W/in<sup>2</sup></b> <b>0.475" Dia.</b> <b>Incoloy®</b> (3.6 W/cm <sup>2</sup> ) (12 mm)	39	(991)	27	(686)	1000	<b>RGNA391S</b>	<b>RGNA3910S</b>	<b>RGNA3911S</b>	1.2	(0.6)	
	54	(1372)	42	(1067)	1500		<b>RGNA5410S</b>	<b>RGNA5411S</b>	1.6	(0.8)	
	69	(1753)	57	(1448)	2000		<b>RGNA6910S</b>	<b>RGNA6911S</b>	2.1	(1.0)	
	84	(2134)	72	(1829)	2500		<b>RGNA8410S</b>	<b>RGNA8411S</b>	2.5	(1.2)	
	99	(2515)	87	(2210)	3000		<b>RGNA9910S</b>	<b>RGNA9911S</b>	3.0	(1.4)	
	106	(2692)	94	(2388)	2778			<b>RGNA10611S</b>		3.2	(1.5)
	132	(3353)	120	(3048)	4167			<b>RGNA13211S</b>		4.0	(1.8)
157	(3988)	145	(3683)	5000		<b>RGNA15710S</b>	<b>RGNA15711S</b>	4.7	(2.2)		

#### Applications: Light Oils, Greases, Heat-Transfer Oils

<b>23 W/in<sup>2</sup></b> <b>0.315" Dia.</b> <b>Steel</b> (3.6 W/cm <sup>2</sup> ) (8 mm)	16	(406)	12	(305)	250	<b>RBS161S</b>	<b>RBS1610S</b>		0.2	(0.1)
	18	(457)	14	(356)	250	<b>RBS181S</b>			0.3	(0.2)
	21	(533)	17	(432)	350	<b>RBS211S</b>	<b>RBS2110S</b>		0.3	(0.2)
	23 $\frac{3}{8}$	(594)	19 $\frac{3}{8}$	(492)	375	<b>RBS23G1S</b>			0.3	(0.2)
	28 $\frac{3}{8}$	(733)	24 $\frac{3}{8}$	(632)	500	<b>RBS28R1S</b>			0.4	(0.2)
	29	(737)	24	(610)	500	<b>RBS291S</b>	<b>RBS2910S</b>		0.4	(0.2)
	42	(1067)	37	(940)	750	<b>RBS421S</b>	<b>RBS4210S</b>		0.6	(0.3)
	54	(1372)	49	(1245)	1000	<b>RBS541S</b>	<b>RBS5410S</b>		0.7	(0.4)
77	(1956)	72	(1829)	1500	<b>RBS771S</b>	<b>RBS7710S</b>		1.0	(0.5)	

CONTINUED

All heating elements are Stock unless otherwise noted.

Truck Shipment only

#### Availability

**Stock:** Same day shipment

**Standard:** Straight length, three weeks;  
formed with options, four weeks

# Tubular and Process Assemblies

## WATROD Heating Elements

### Double-Ended WATROD

WATROD Description	Sheath A Dimension		Heated B Dimension		Watts	Code Number			Est. Net Weight	
	inch	(mm)	inch	(mm)		120V~(ac)	240V~(ac)	480V~(ac)	lbs	(kg)

#### Applications: Light Oils, Greases, Heat-Transfer Oils

<b>23 W/in<sup>2</sup></b> <b>0.475" Dia.</b> <b>Steel</b> (3.6 W/cm <sup>2</sup> ) (12 mm)	23	(584)	14	(356)	500	<b>RGS231S</b>	<b>RGS2310S</b>		0.7	(0.4)
	31	(787)	22	(559)	750	<b>RGS311S</b>	<b>RGS3110S</b>		1.0	(0.5)
	39	(991)	27	(686)	1000	<b>RGS391S</b>	<b>RGS3910S</b>	<b>RGS3911S</b>	1.2	(0.6)
	45	(1143)	36	(914)	1250	<b>RGS451S</b>	<b>RGS4510S</b>		1.4	(0.7)
	54	(1372)	42	(1067)	1500	<b>RGS541S</b>	<b>RGS5410S</b>	<b>RGS5411S</b>	1.6	(0.8)
	69	(1753)	57	(1448)	2000	<b>RGS691S</b>	<b>RGS6910S</b>	<b>RGS6911S</b>	2.1	(1.0)
	84	(2134)	72	(1829)	2500	<b>RGS841S</b>	<b>RGS8410S</b>	<b>RGS8411S</b>	2.5	(1.2)
	99	(2515)	87	(2210)	3000		<b>RGS9910S</b>	<b>RGS9911S</b>	3.0	(1.4)
	106	(2692)	90	(2286)	2778			<b>RGS10611S</b>	3.2	(1.5)
	132	(3353)	120	(3048)	4167		<b>RGS13210S</b>	<b>RGS13211S</b>	4.0	(1.8)
	144	(3658)	128	(3251)	3889			<b>RGS14411S</b>	4.3	(2.0)
	157	(3988)	145	(3683)	5000		<b>RGS15710S</b>	<b>RGS15711S</b>	4.7	(2.2)

#### Application: Air Heating

<b>30 W/in<sup>2</sup></b> <b>0.260" Dia.</b> <b>Incoloy®</b> (4.7 W/cm <sup>2</sup> ) (6.6 mm)	20	(508)	15	(381)	400		<b>RAN2010S</b>		0.2	(0.1)
	25	(635)	20	(508)	500		<b>RAN2510S</b>		0.3	(0.2)
	30	(762)	25	(635)	600		<b>RAN3010S</b>		0.3	(0.2)
	35	(889)	30	(762)	800		<b>RAN3510S</b>		0.4	(0.2)
	40	(1016)	35	(889)	900		<b>RAN4010S</b>		0.4	(0.2)
	45	(1143)	40	(1016)	1000		<b>RAN4510S</b>		0.5	(0.3)
	50	(1270)	45	(1143)	1200		<b>RAN5010S</b>		0.5	(0.3)
	55	(1397)	50	(1270)	1200		<b>RAN5510S</b>		0.6	(0.3)
	60	(1524)	55	(1397)	1400		<b>RAN6010S</b>		0.6	(0.3)
	65	(1651)	60	(1524)	1600		<b>RAN6510S</b>		0.7	(0.4)
	70	(1778)	65	(1651)	1800		<b>RAN7010S</b>		0.7	(0.4)
	75	(1905)	70	(1778)	1800		<b>RAN7510S</b>		0.8	(0.4)
	80	(2032)	75	(1905)	2000		<b>RAN8010S</b>		0.8	(0.4)
<b>30 W/in<sup>2</sup></b> <b>0.315" Dia.</b> <b>Incoloy®</b> (4.7 W/cm <sup>2</sup> ) (8 mm)	15	(381)	10	(254)	300		<b>RBN1510S</b>		0.2	(0.1)
	20	(508)	15	(381)	400		<b>RBN2010S</b>		0.3	(0.2)
	25	(635)	20	(508)	600		<b>RBN2510S</b>		0.4	(0.2)
	30	(762)	25	(635)	800		<b>RBN3010S</b>		0.4	(0.2)
	35	(889)	30	(762)	900		<b>RBN3510S</b>		0.5	(0.3)
	40	(1016)	35	(889)	1000		<b>RBN4010S</b>		0.5	(0.3)
	45	(1143)	40	(1016)	1200		<b>RBN4510S</b>		0.6	(0.3)
	50	(1270)	45	(1143)	1400		<b>RBN5010S</b>		0.7	(0.4)
	55	(1397)	50	(1270)	1600		<b>RBN5510S</b>		0.7	(0.4)
	60	(1524)	55	(1397)	1800		<b>RBN6010S</b>		0.8	(0.4)
	65	(1651)	60	(1524)	1800		<b>RBN6510S</b>		0.8	(0.4)
	70	(1778)	65	(1651)	2000		<b>RBN7010S</b>		0.9	(0.5)
	75	(1905)	70	(1778)	2200		<b>RBN7510S</b>		1.0	(0.5)
80	(2032)	75	(1905)	2400		<b>RBN8010S</b>		1.0	(0.5)	
90	(2286)	85	(2159)	2600		<b>RBN9010S</b>		1.2	(0.6)	
100	(2540)	95	(2413)	3000		<b>RBN10010S</b>		1.3	(0.6)	

CONTINUED

All heating elements are Stock unless otherwise noted.      Truck Shipment only

#### Availability

**Stock:** Same day shipment

**Standard:** Straight length, three weeks; formed with options, four weeks

WATROD

# Tubular and Process Assemblies

## WATROD Heating Elements

### Double-Ended WATROD

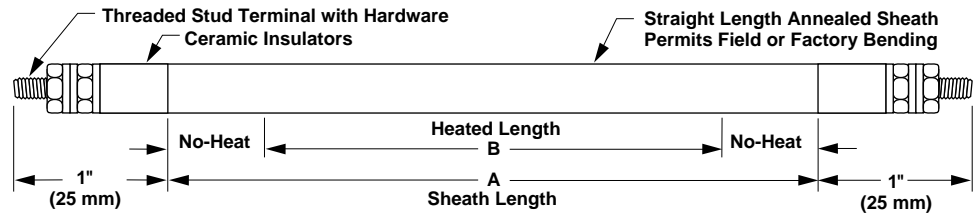

WATROD Description	Sheath A Dimension		Heated B Dimension		Watts	Code Number			Est. Net Weight	
	inch	(mm)	inch	(mm)		120V~(ac)	240V~(ac)	480V~(ac)	lbs	(kg)

### Application: Air Heating

<b>30 W/in<sup>2</sup></b> <b>0.430" Dia.</b> <b>Incoloy®</b> (4.7 W/cm <sup>2</sup> ) (10.9 mm)	15	(381)	10	(254)	400		<b>RCN1510S</b>		0.3	(0.2)
	20	(508)	15	(381)	600		<b>RCN2010S</b>		0.4	(0.2)
	25	(635)	20	(508)	800		<b>RCN2510S</b>		0.5	(0.3)
	30	(762)	25	(635)	1000		<b>RCN3010S</b>		0.6	(0.3)
	35	(889)	30	(762)	1200		<b>RCN3510S</b>		0.7	(0.4)
	40	(1016)	35	(889)	1400		<b>RCN4010S</b>		0.8	(0.4)
	48 <sup>3</sup> / <sub>4</sub>	(1238)	38 <sup>3</sup> / <sub>4</sub>	(984)	1500		<b>RCNX48N10S</b>	<b>RCNX48N11S</b>	1.0	(0.5)
	45	(1143)	40	(1016)	1600		<b>RCN4510S</b>		0.9	(0.5)
	50	(1270)	45	(1143)	1800		<b>RCN5010S</b>		1.0	(0.5)
	58 <sup>3</sup> / <sub>4</sub>	(1492)	48 <sup>3</sup> / <sub>4</sub>	(1238)	1917		<b>RCNX58N10S</b>	<b>RCNX58N11S</b>	1.1	(0.5)
	55	(1397)	50	(1270)	2000		<b>RCN5510S</b>		1.0	(0.5)
	60	(1524)	55	(1397)	2200		<b>RCN6010S</b>		1.1	(0.5)
	65	(1651)	60	(1524)	2400		<b>RCN6510S</b>		1.2	(0.6)
	73 <sup>3</sup> / <sub>4</sub>	(1873)	63 <sup>3</sup> / <sub>4</sub>	(1619)	2500			<b>RCNX73N11S</b>	1.4	(0.7)
	70	(1778)	65	(1651)	2600		<b>RCN7010S</b>		1.3	(0.6)
	75	(1905)	70	(1778)	2800		<b>RCN7510S</b>		1.4	(0.7)
	80	(2032)	75	(1905)	3000		<b>RCN8010S</b>		1.5	(0.7)
	91 <sup>3</sup> / <sub>4</sub>	(2330)	81 <sup>3</sup> / <sub>4</sub>	(2076)	3167			<b>RCNX91N11S</b>	1.7	(0.8)
90	(2286)	85	(2159)	3500		<b>RCN9010S</b>		1.7	(0.8)	
100	(2540)	95	(2413)	4000		<b>RCN10010S</b>		1.9	(0.9)	
110	(2794)	105	(2667)	4500		<b>RCN11010S</b>		2.1	(1.0)	
120	(3048)	115	(2921)	5000		<b>RCN12010S</b>		2.3	(1.1)	

### Application: Radiant Heating

<b>40 W/in<sup>2</sup></b> <b>0.375" Dia.</b> <b>Incoloy®</b> (6.2 W/cm <sup>2</sup> ) (9.5 mm)	10 <sup>1</sup> / <sub>4</sub>	(260)	7 <sup>1</sup> / <sub>4</sub>	(184)	400	<b>RDN10E1S</b>			0.2	(0.1)
	16 <sup>1</sup> / <sub>2</sub>	(422)	13 <sup>1</sup> / <sub>2</sub>	(346)	650	<b>RDN16L1S</b>			0.3	(0.2)
	21 <sup>1</sup> / <sub>6</sub>	(535)	16 <sup>1</sup> / <sub>6</sub>	(427)	800	<b>RDN21B1S</b>	<b>RDN21B10S</b>		0.4	(0.2)
	27 <sup>1</sup> / <sub>6</sub>	(689)	22 <sup>1</sup> / <sub>6</sub>	(581)	1100	<b>RDN27C1S</b>	<b>RDN27C10S</b>		0.5	(0.3)
	32 <sup>1</sup> / <sub>6</sub>	(816)	27 <sup>1</sup> / <sub>6</sub>	(708)	1300		<b>RDN32C10S</b>	<b>RDN32C11S</b>	0.6	(0.3)
	42 <sup>1</sup> / <sub>6</sub>	(1089)	38 <sup>1</sup> / <sub>6</sub>	(981)	1800		<b>RDN42R10S</b>	<b>RDN42R11S</b>	0.8	(0.4)
	57 <sup>1</sup> / <sub>2</sub>	(1461)	53 <sup>1</sup> / <sub>4</sub>	(1353)	2500		<b>RDN57J10S</b>	<b>RDN57J11S</b>	1.1	(0.5)
	69 <sup>1</sup> / <sub>4</sub>	(1759)	65	(1651)	3000		<b>RDN69E10S</b>	<b>RDN69E11S</b>	1.3	(0.6)
	81 <sup>1</sup> / <sub>4</sub>	(2064)	77	(1956)	3600		<b>RDN81E10S</b>	<b>RDN81E11S</b>	1.6	(0.8)
	109 <sup>1</sup> / <sub>4</sub>	(2775)	105	(2667)	4000		<b>RDN109E10S</b> Ⓢ		2.1	(1.0)
	134 <sup>1</sup> / <sub>2</sub>	(3416)	127 <sup>3</sup> / <sub>4</sub>	(3245)	5000		<b>RDN134J10S</b> Ⓢ		2.6	(1.2)
	153 <sup>3</sup> / <sub>8</sub>	(3896)	145 <sup>3</sup> / <sub>8</sub>	(3705)	5500		<b>RDN153R10S</b> Ⓢ		2.9	(1.4)
	179 <sup>1</sup> / <sub>4</sub>	(4553)	171 <sup>1</sup> / <sub>4</sub>	(4350)	6500		<b>RDN179E10S</b> Ⓢ		3.4	(1.6)

CONTINUED

All heating elements are Stock unless otherwise noted.

Ⓢ Standard

#### Availability

Truck Shipment only

**Stock:** Same day shipment

**Standard:** Straight length, three weeks; formed with options, four weeks

# Tubular and Process Assemblies

## WATROD Heating Elements

### Double-Ended WATROD

#### Special 208V~(ac) and 277V~(ac) Voltages

WATROD Description	Sheath A Dimension		Heated B Dimension		Watts	Code Number		Est. Net Weight	
	inch	(mm)	inch	(mm)		208V~(ac)	277V~(ac)	lbs	(kg)

#### Application: Radiant Heating

<b>40 W/in<sup>2</sup></b> <b>0.375" Dia.</b> <b>Incoloy®</b> (6.2 W/cm <sup>2</sup> ) (9.5 mm)	21 1/16	(535)	16 13/16	(427)	800	<b>RDN21B2S</b> Ⓢ	<b>RDN21B4S</b> Ⓢ	0.4	(0.2)
	27 1/8	(689)	22 7/8	(581)	1100	<b>RDN27C2S</b> Ⓢ	<b>RDN27C4S</b> Ⓢ	0.5	(0.3)
	42 7/8	(1089)	38 5/8	(981)	1800	<b>RDN42R2S</b> Ⓢ	<b>RDN42R4S</b> Ⓢ	0.8	(0.4)
	57 1/2	(1461)	53 1/4	(1353)	2500	<b>RDN57J2S</b> Ⓢ	<b>RDN57J4S</b> Ⓢ	1.1	(0.5)
	69 1/4	(1759)	65	(1651)	3000	<b>RDN69E2S</b> Ⓢ	<b>RDN69E4S</b> Ⓢ	1.3	(0.6)
	81 1/4	(2064)	77	(1956)	3600	<b>RDN81E2S</b> Ⓢ	<b>RDN81E4S</b> Ⓢ	1.6	(0.8)

WATROD Description	Sheath A Dimension		Heated B Dimension		Watts	Code Number			Est. Net Weight	
	inch	(mm)	inch	(mm)		120V~(ac)	240V~(ac)	480V~(ac)	lbs	(kg)

#### Application: Process Water

<b>48 W/in<sup>2</sup></b> <b>0.475" Dia.</b> <b>Incoloy®</b> (7.4 W/cm <sup>2</sup> ) (12 mm)	23	(584)	14	(356)	1000	<b>RGN231S</b>	<b>RGN2310S</b>	<b>RGN2311S</b>	0.7	(0.4)
	30	(762)	21	(533)	1500	<b>RGN301S</b>	<b>RGN3010S</b>	<b>RGN3011S</b>	0.9	(0.5)
	39	(991)	27	(686)	2000	<b>RGN391S</b>	<b>RGN3910S</b>	<b>RGN3911S</b>	1.2	(0.6)
	44	(1118)	35	(889)	2500	<b>RGN441S</b>	<b>RGN4410S</b>	<b>RGN4411S</b>	1.3	(0.6)
	54	(1372)	42	(1067)	3000		<b>RGN5410S</b>	<b>RGN5411S</b>	1.6	(0.8)
	69	(1753)	57	(1448)	4000		<b>RGN6910S</b>	<b>RGN6911S</b>	2.1	(1.0)
	84	(2134)	72	(1829)	5000		<b>RGN8410S</b>	<b>RGN8411S</b>	2.5	(1.2)
	92	(2337)	76	(1930)	5556			<b>RGN9211S</b>	2.8	(1.3)
	99	(2515)	87	(2210)	6000		<b>RGN9910S</b>	<b>RGN9911S</b>	3.0	(1.4)
	149	(3785)	133	(3378)	9722			<b>RGN14911S</b>	4.5	(2.1)

#### Application: Hot Runner Molds (Manifolds)

<b>60 W/in<sup>2</sup></b> <b>0.315" Dia.</b> <b>316 SS</b> (9.3 W/cm <sup>2</sup> ) (8 mm)	35	(889)	25	(635)	1500		<b>RBR3510S</b>		0.2	(0.1)
	44	(1118)	34	(864)	2000		<b>RBR4410S</b>		0.3	(0.2)
	52	(1321)	42	(1067)	2500		<b>RBR5210S</b>		0.3	(0.2)
	60	(1524)	50	(1270)	3000		<b>RBR6010S</b>		0.4	(0.2)
	69	(1753)	59	(1499)	3500		<b>RBR6910S</b>		0.4	(0.2)
	77	(1956)	67	(1702)	4000		<b>RBR7710S</b>		0.5	(0.3)
	85	(2159)	75	(1905)	4500		<b>RBR8510S</b>		0.6	(0.3)

#### Applications: Deionized Water, Demineralized Water

<b>60 W/in<sup>2</sup></b> <b>0.475" Dia.</b> <b>316 SS</b> (9.3 W/cm <sup>2</sup> ) (12 mm)	20	(508)	11	(279)	1000	<b>RGR201S</b>	<b>RGR2010S</b>	<b>RGR2011S</b>	0.6	(0.3)
	26	(660)	17	(432)	1500	<b>RGR261S</b>	<b>RGR2610S</b>	<b>RGR2611S</b>	0.8	(0.4)
	34	(864)	22	(559)	2000		<b>RGR3410S</b>	<b>RGR3411S</b>	1.0	(0.5)
	40	(1016)	28	(711)	2500		<b>RGR4010S</b>	<b>RGR4011S</b>	1.2	(0.6)
	47	(1194)	31	(787)	2778			<b>RGR4711S</b>	1.4	(0.7)
	46	(1168)	34	(864)	3000		<b>RGR4610S</b>	<b>RGR4611S</b>	1.4	(0.7)
	57	(1448)	45	(1143)	4000		<b>RGR5710S</b>	<b>RGR5711S</b>	1.7	(0.8)
	68	(1727)	56	(1422)	5000		<b>RGR6810S</b>	<b>RGR6811S</b>	2.1	(1.0)
	79	(2007)	67	(1702)	6000		<b>RGR7910S</b>	<b>RGR7911S</b>	2.4	(1.1)
	105	(2667)	93	(2362)	8333			<b>RGR10511S</b>	3.2	(1.5)

CONTINUED

All heating elements are Stock unless otherwise noted.

Ⓢ Standard

#### Availability

**Stock:** Same day shipment

**Standard:** Straight length, three weeks; formed with options, four weeks

■ Truck Shipment only.

# Tubular and Process Assemblies

## WATROD Heating Elements

### Double-Ended WATROD

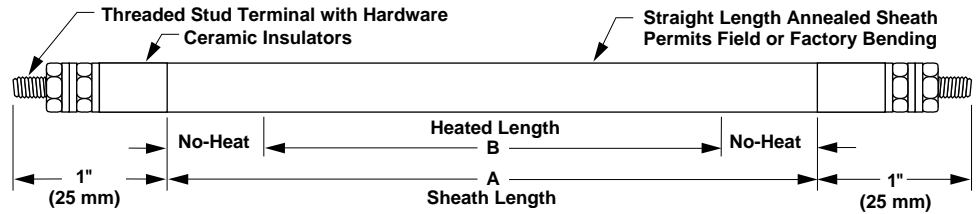

WATROD Description	Sheath A Dimension		Heated B Dimension		Watts	Code Number			Est. Net Weight	
	inch	(mm)	inch	(mm)		120V~(ac)	240V~(ac)	480V~(ac)	lbs	(kg)

#### Application: Clean Water

60 W/in <sup>2</sup> 0.315" Dia. Copper (9.3 W/cm <sup>2</sup> ) (8 mm)	12	(305)	8	(203)	500	RBC121S	RBC1210S		0.2	(0.1)
	16	(406)	12	(305)	750	RBC161S	RBC1610S		0.2	(0.1)
	19%	(505)	12%	(327)	750	RBC19R1S			0.3	(0.2)
	20	(508)	16	(406)	1000	RBC201S	RBC2010S		0.3	(0.2)
	23%	(603)	16%	(425)	1000	RBC23N1S			0.3	(0.2)
	24	(610)	20	(508)	1250	RBC241S	RBC2410S		0.3	(0.2)
	27%	(705)	20%	(527)	1250	RBC27N1S			0.4	(0.2)
	33	(838)	26	(660)	1500	RBC331S	RBC3310S		0.5	(0.3)
	41	(1041)	34	(864)	2000	RBC411S	RBC4110S		0.6	(0.3)
	50	(1270)	43	(1092)	2500	RBC501S <sup>Ⓜ</sup>	RBC5010S <sup>Ⓜ</sup>		0.7	(0.4)
58	(1473)	51	(1295)	3000	RBC581S <sup>Ⓜ</sup>	RBC5810S <sup>Ⓜ</sup>		0.8	(0.4)	
74	(1880)	67	(1702)	4000		RBC7410S <sup>Ⓜ</sup>		1.0	(0.5)	
60 W/in <sup>2</sup> 0.475" Dia. Copper (9.3 W/cm <sup>2</sup> ) (12 mm)	20	(508)	11	(279)	1000	RGC201S	RGC2010S		0.6	(0.3)
	26	(660)	17	(432)	1500	RGC261S	RGC2610S	RGC2611S	0.8	(0.4)
	34	(864)	22	(559)	2000	RGC341S	RGC3410S	RGC3411S	1.0	(0.5)
	40	(1016)	28	(711)	2500	RGC401S	RGC4010S	RGC4011S	1.2	(0.6)
	46	(1169)	34	(864)	3000		RGC4610S <sup>Ⓜ</sup>	RGC4611S <sup>Ⓜ</sup>	1.4	(0.7)
	47	(1194)	31	(787)	2778			RGC4711S <sup>Ⓜ</sup>	1.4	(0.7)
	57	(1448)	45	(1143)	4000		RGC5710S <sup>Ⓜ</sup>	RGC5711S <sup>Ⓜ</sup>	1.7	(0.8)
	68	(1727)	56	(1422)	5000		RGC6810S <sup>Ⓜ</sup>	RGC6811S <sup>Ⓜ</sup>	2.1	(1.0)
	78	(1981)	62	(1575)	5556			RGC7811S <sup>Ⓜ</sup>	2.4	(1.1)
	79	(2007)	67	(1702)	6000		RGC7910S <sup>Ⓜ</sup>	RGC7911S <sup>Ⓜ</sup>	2.4	(1.1)
105	(2661)	93	(2362)	8333			RGC10511S <sup>Ⓜ</sup>	3.2	(1.5)	

All heating elements are Stock unless otherwise noted.

#### Availability

**Stock:** Same day shipment

**Standard:** Straight length, three weeks; formed with options, four weeks

<sup>Ⓜ</sup> Stocked unannealed. Allow one day for annealing. Specify **DO NOT ANNEAL** if annealed WATROD not required.

Truck Shipment only

# Tubular and Process Assemblies

## WATROD Heating Elements

### Single-Ended WATROD Application Hints

The single-ended WATROD heater's construction limits its usefulness in some applications. The following are some guides to follow when considering a single-ended WATROD.

- When single-ended termination simplifies application wiring.
- Your application requires lower wattage or a smaller package.
- Do not locate the end of the heated length within a bend, unless the radius is three inches (75 mm) or more. Field bending is not recommended.
- Bending is limited to bend Figures 1, 6, 22 and 28 (see pages 282 to 286 for details).
- Ensure termination temperatures do not exceed 390°F (200°C) or the seal's maximum rating.
- Keep terminations clean, dry and tight.

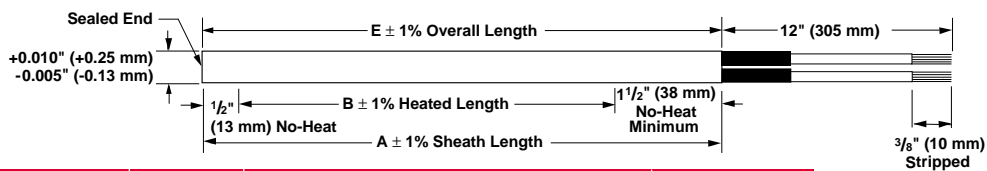

### Single-Ended WATROD

WATROD Description	Sheath A Dimension		Heated B Dimension		Watts	Code Number		Est. Net Weight	
	inch	(mm)	inch	(mm)		120V~(ac)	240V~(ac)	lbs	(kg)

#### Applications: Platen and Forced Air Heating, and Deicing

<b>20 W/in<sup>2</sup></b>	15	(381)	11 ½	(292)	270	<b>RSN151W</b>	<b>RSN1510W</b>	0.3	(0.2)
<b>0.375" Dia.</b>	20	(508)	16 ½	(419)	390	<b>RSN201W</b>	<b>RSN2010W</b>	0.4	(0.2)
<b>Incoloy®</b>	25	(635)	21 ½	(546)	500	<b>RSN251W</b>	<b>RSN2510W</b>	0.5	(0.3)
(3.1 W/cm <sup>2</sup> )	30	(762)	26 ½	(673)	625	<b>RSN301W</b>	<b>RSN3010W</b>	0.6	(0.3)
(9.5 mm)	35	(889)	31 ½	(800)	750	<b>RSN351W</b>	<b>RSN3510W</b>	0.7	(0.4)
	40	(1016)	36 ½	(927)	860	<b>RSN401W</b>	<b>RSN4010W</b>	0.8	(0.4)

All heating elements are Standard units.

#### Availability

**Standard:** Shipment within six weeks

**F.O.B.:** Hannibal, Missouri

#### How to Order

##### Single or Double-Ended WATROD

To order a stock, standard or assembly stock WATROD element, specify:

- Watlow code number
- Volts/watts
- Termination options
- Options
- Quantity

If stock WATROD heaters do not meet your application needs, Watlow can provide a made-to-order unit. Please specify:

- Description of application, including heated material, operating temperature and flow rate, etc.
- Volts/watts
- Sheath material/diameter
- Sheath length

- Single or double-ended
- Heated length
- No-heat length at each end
- Terminal pin length or termination options
- Moisture seal type
- Bend configuration, dimensions and critical tolerances (send drawing, if available)
- Options, including external finish and mounting method
- Quantity

#### Availability

##### Double-Ended WATROD

##### Straight Length Element

**Stock:** Same day shipment

**Modified Stock<sup>Ⓢ</sup>:** Three to five working days

**Standard:** 10 working days

**Made-to-Order:** Three weeks

##### Formed Element

**Modified Stock<sup>Ⓢ</sup>:** Five to seven working days

**Standard:** Three weeks

**Made-to-Order:** Four to five weeks

##### Single-Ended WATROD

##### Straight Length Element

**Modified Stock<sup>Ⓢ</sup>:** Three weeks

**Standard:** Three weeks

**Made-to-Order:** Three weeks

##### Formed Element

**Modified Stock<sup>Ⓢ</sup>:** Three weeks

**Standard:** Three weeks

**Made-to-Order:** Four to five weeks

Options, complexity and quantity may affect availability and lead times. Consult factory.

<sup>Ⓢ</sup> Stock units with catalog options.

WATROD

# Tubular and Process Assemblies

## WATROD Heating Elements

### Enclosure Heaters

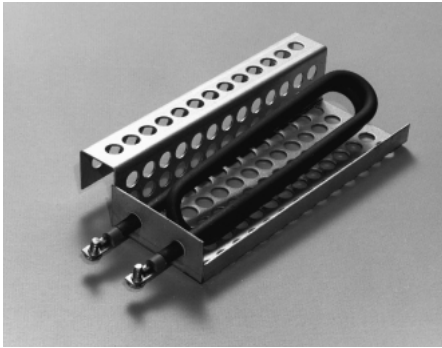

Designed to prevent freezing and condensation in electrical and mechanical housings, the WATROD element is enclosed in a perforated, aluminized-steel bracket.

#### Performance Capabilities

- Watt densities to 15 W/in<sup>2</sup> (2.3 W/cm<sup>2</sup>)
- Wattages to 1000 watts
- UL® and CSA component recognition to 250V~(ac)

#### Features and Benefits

- **Stainless steel sheath wall** further resists corrosion and protects the heating coil from exposure.

- **Silicone resin seal** provides protection against humid storage conditions and is effective to 390°F (200°C).
- **Perforated aluminized-steel mounting bracket** eases installation and helps prevent direct contact with the heating element.
- **Stock straight projection Type B #10-32 screw lug terminals** provide easy electrical connection.
- **Made-to-Order threaded stud**, quick connect and flexible lead wire termination options. See **page 281** for details.

#### Applications

- Control panels
- Traffic signal boxes
- Automatic teller machines
- Switch gear
- Electronic equipment

#### Application Hints

- Locate heater(s) in the lowest portion of the enclosure to maximize convection heating.
- Place thermostat(s) in the upper half of the enclosure, away from the heater(s).

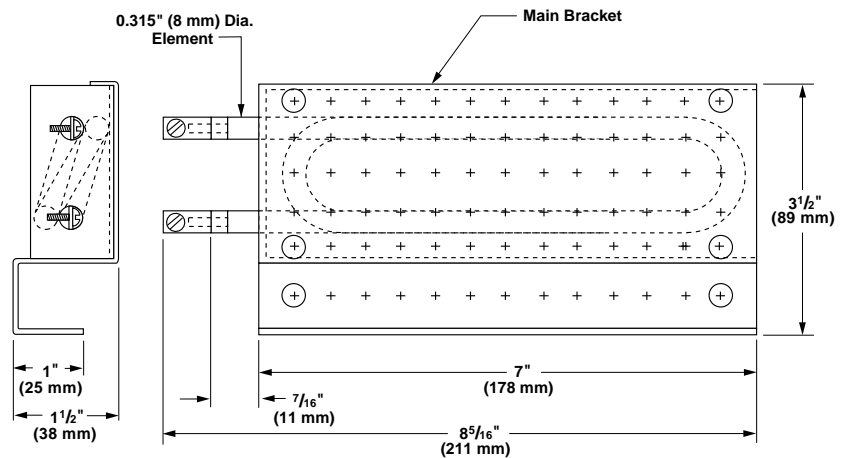

Watts	Watt Density		Code No.		Availability	Est. Net Weight	
	W/in <sup>2</sup>	(W/cm <sup>2</sup> )	125V~(ac)	250V~(ac)		lbs	(kg)
95	4	(0.6)	<b>EN951</b>		Stock	1.5	(0.7)
100	4	(0.6)		<b>EN10010</b>	Stock	1.5	(0.7)
250	10	(1.6)	<b>EN2501</b>	<b>EN25010</b>	Stock	1.5	(0.7)
375	15	(2.3)	<b>EN3751</b>	<b>EN37510</b>	Stock	1.5	(0.7)

F.O.B.: Hannibal, Missouri

#### How to Order

To order a stock WATROD enclosure heater, please specify:

- Watlow code number
- Volts/watts
- Termination options
- Options
- Quantity

If our stock units do not meet your application, Watlow can provide

**made-to-order** enclosure heaters. Please specify:

- Volts/watts
- Sheath diameter/material
- No-heat section
- A, C, H, L and R dimensions per Figure 8 bend formation shown on catalog **page 283**.
- Termination options
- Options
- Quantity

#### Availability

**Stock:** Same day shipment

**Modified Stock**Ⓞ: Three to five working days

**Made-to-Order:** Four to five weeks

Options, complexity and quantity may affect availability and lead times. Consult factory.

Ⓞ Stock units with catalog options.

# Tubular and Process Assemblies

F.O.B.: Hannibal, Missouri

## WATROD Heating Elements

### Plastics Application



### Hot Runner Mold (Manifold) Features and Benefits

- **Precise conformity to customer specifications** ensures easy installation—bending tolerances as low as  $\pm 0.002$  inch.
- **Common element diameters** include: 0.260, 0.315, 0.335, 0.375 and 0.430 inch (6.6, 8, 8.5, 9.5 and 10.9 mm).
- **Incoloy® sheath material** for high temperatures, 304 stainless steel for smaller radius bends.
- **Superior resistance coil design** produces even heating.
- **Threaded stud or leadwire termination** as required.

Use the *Milled Groove Sheath Watt Density and Groove Fit* chart to find the recommended watt density or tightest groove fit. Optimum groove fit, without heat transfer cement, can be determined by plotting the intersect point between the required sheath watt density and the Delta temperature (T). If the Delta T is not known, simply subtract the mold temperature from the maximum 1000°F (540°C) sheath temperature. Any combination of watt density and groove fit which results in a Delta T below the recommended maximum will maximize heater life. Conversely, if the Delta T is greater, less heater life can be expected.

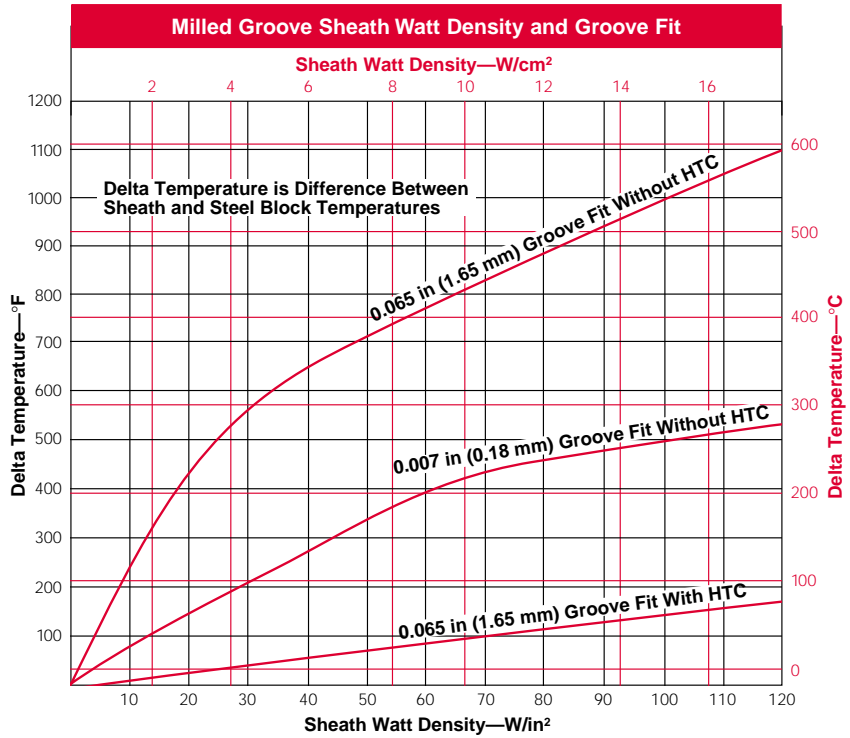

- Recommended maximum watt density = 40 to 70 W/in<sup>2</sup> (6.2 to 10.9 W/cm<sup>2</sup>)
- Recommended groove = 0.065 inch (1.65 mm) larger in diameter than sheath diameter, and use heat transfer cement.
- Recommended heater sheath diameter = 0.315 inch (8 mm)
- Recommended maximum Delta T = 400°F (205°C)
- Maximum sheath temperature = 1000°F (540°C)
- Recommended sheath material = Incoloy®

### How to Order

All milled groove heaters are made-to-order. Due to precision forming requirements, please provide a detailed drawing or CAD disk. Consult your Watlow representative for price and shipment details. To help the ordering process, provide the following information:

- Operating temperature
- Volts/watts
- Sheath diameter and material
- No-heat section
- Electrical terminations
- Bend configurations and dimensions
- Groove cross section dimensions
- Quantity

### Replacement Heaters

To order a replacement for an existing milled groove heater, specify original Watlow code

number, or provide dimensions of the competitive heater, or the groove dimensions from the manifold.

### Heat Transfer Cement (HTC)

Heat transfer cement can maximize heater performance and life by increasing thermal conductivity between the sheath and manifold. The maximum exposure temperature is 1250°F (675°C). Available in one quart cans. To order, specify **code number 148-15-2-1**.



### Caution

Heat transfer cement conducts electricity. Avoid contact with terminations, wiring and other sources of electric current.

# Tubular and Process Assemblies

## WATROD Heating Elements

### Semiconductor Application



Sheath temperatures can vary up to a maximum sheath temperature of 1832°F (1000°C), with maximum watt densities up to 60 W/in<sup>2</sup>. Individual element and assembly specifications vary depending on the application. Contact factory for E-beam welding, vacuum brazing and special plating.

#### Features and Benefits

- Operating temperatures to 1832°F (1000°C)
- Electrical isolation to a minimum of 10 teraohms, high isolation resistance heater only
- Vacuum compatibility to 10<sup>-9</sup> Torr
- Nitrogen purge vacuum packaging
- Milled groove patterning to 0.25 inch (6.35 mm) radius
- Materials: stainless steel, Incoloy®, Inconel®, aluminum, nickel, copper

- Heated part assemblies: hot plates, vacuum fittings, special formed heaters
- Round elements from 0.210 to 0.475 inch (5.3 to 12.1 mm) diameter
- FIREBAR heating elements from 0.625 to 1.00 inch (15.9 to 25.4 mm) wide
- X-Ray capabilities and testing certification for ensured reliability.

#### Applications

- CVD
- PVD
- Etch
- Photolithography
- Annealing
- Wafer probers
- Flat panel display

---

#### External Finishes

- Black oxide
- Bright anneal
- Glass bead
- Belt polish
- Electropolish

---

#### ULTRAGARD Seal

A high temperature hermetic seal to 700°F (350°C).

For special plating, consult the factory.

## Tubular and Process Assemblies

### FIREBAR Heating Elements

FIREBAR® heating elements provide added heating performance over standard round tubular heating elements—especially for immersion applications in petroleum based liquids that require high kilowatts. The FIREBAR's unique flat surface geometry packs more power in shorter elements and assemblies, along with a host of other performance improvements. These include:

- Minimizing coking and fluid degrading
- Enhancing the flow of fluid past the element's surface to carry heat from the sheath
- Improving heat transfer with a significantly larger boundary layer that allows much more liquid to flow up and across the sheath's surface.

FIREBAR elements are available in single- and double-ended constructions with one inch or 5/8 inch heights. These two configuration variables make it possible to use FIREBAR elements instead of round tubular elements in virtually all applications.

**FINBAR** is a special version of the one inch, single-ended FIREBAR. FINBAR is specially modified with fins to further increase surface area for air and gas heating applications. Details are contained in the FINBAR section, starting on [page 318](#).

#### Double-Ended Performance Capabilities

##### One Inch

- Watt densities to 120 W/in<sup>2</sup> (18.6 W/cm<sup>2</sup>)
- Incoloy® sheath temperatures to 1400°F (760°C)
- 304 stainless steel sheath temperatures to 1200°F (650°C)

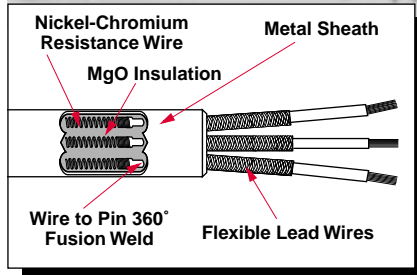
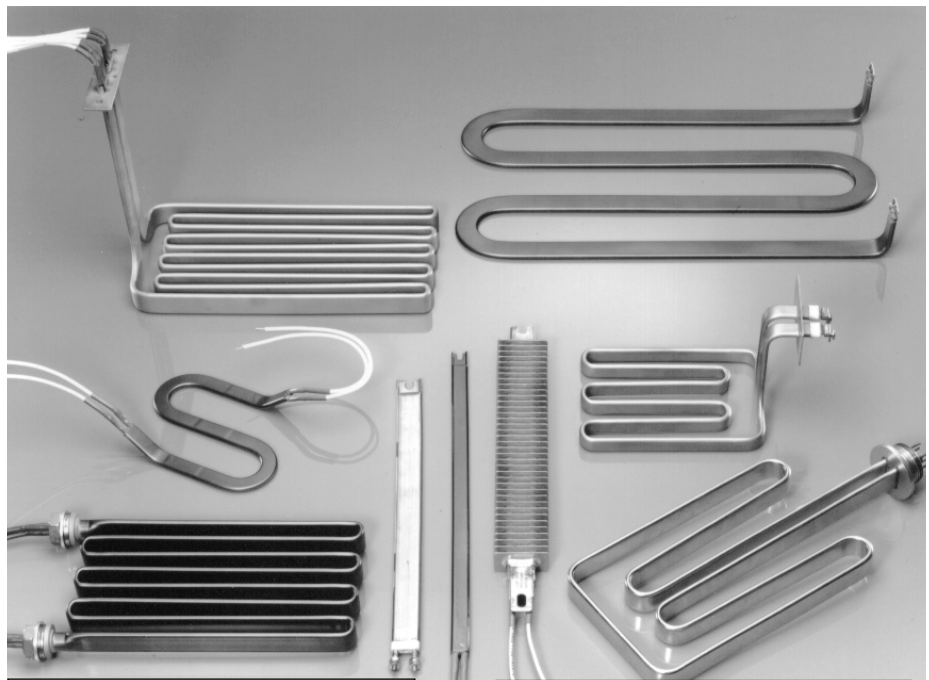

One Inch Double-Ended FIREBAR Element and Lead Configurations

- Voltages to 480V~(ac)
  - Amperages to 48 amps per heater or 16 amps per coil
- 5/8 Inch**
- Watt densities to 90 W/in<sup>2</sup> (13.9 W/cm<sup>2</sup>)
  - Incoloy® sheath temperatures to 1400°F (760°C)
  - Voltages to 480V~(ac)
  - Amperages to 32 amps per heater or 16 amps per coil

#### Single-Ended Performance Capabilities

##### One Inch

- Watt densities to 60 W/in<sup>2</sup> (9.3 W/cm<sup>2</sup>)

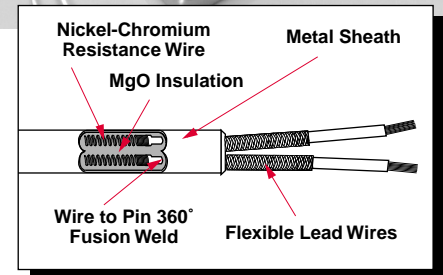

5/8 Inch Double-Ended FIREBAR Element and Lead Configurations

- Incoloy® sheath temperatures to 1400°F (760°C)
- 304 stainless steel sheath temperatures to 1200°F (650°C)
- Voltages to 480V~(ac)
- Amperages to 48 amps per heater or 16 amps per coil

##### 5/8 Inch

- Watt densities to 80 W/in<sup>2</sup> (12.4 W/cm<sup>2</sup>)
- Incoloy® sheath temperatures to 1400°F (760°C)
- Voltages to 480V~(ac)
- Amperages to 25 amps per heater.

Incoloy® is a registered trademark of Special Metals Corporation.

# Tubular and Process Assemblies

## FIREBAR Heating Elements

### Specifications

#### One Inch FIREBAR



#### 5/8 Inch FIREBAR



<b>Applications</b>	Direct immersion; water, oils, etc. Clamp-on; hoppers, griddles Forced air heating (Also see FINBAR, <a href="#">page 318</a> ) Radiant heating	Direct immersion; water, oils, etc. Clamp-on; hoppers, griddles Forced air heating Radiant heating
<b>Watt Density</b> W/in <sup>2</sup> (W/cm <sup>2</sup> )	Stock: up to 90 (13.9) Made-to-Order (M-t-O): up to 120 (18.6)	Stock: up to 90 (13.9) Made-to-Order (M-t-O): up to 90 (13.9)
<b>Surface Area Per Linear Inch (cm)</b>	2.3 in <sup>2</sup> (14.8 cm <sup>2</sup> )	1.52 in <sup>2</sup> (9.80 cm <sup>2</sup> )
<b>Cross Section</b>		
Height ± 0.015/0.010" (0.381/0.254 mm)	1.010 (25.7)	0.650 (16.5)
Thickness ± 0.005/0.001" (0.127/0.025 mm)	0.235 (5.9)	0.235 (5.9)
<b>Sheath Material—Maximum Operating Temperature</b>	Stock: Incoloy® 1400°F (760°C) M-t-O: Incoloy® 1400°F (760°C) 304 S. Steel 1200°F (650°C)	Stock: Incoloy® 1400°F (760°C) M-t-O: Incoloy® 1400°F (760°C) 304 S. Steel 1200°F (650°C)
<b>Sheath Length</b> inch (mm)	Stock: 15 to 114 (381 to 2896) M-t-O: 11 to 180 (280 to 4572)	Stock: 15 to 51 (381 to 1295) M-t-O: 11 to 115 (280 to 2920)
<b>Straightness Tolerance</b>		
Major axis inch/foot (cm/m):	0.062 (0.52)	0.062 (0.52)
Minor axis inch/foot (cm/m):	0.062 (0.52)	0.062 (0.52)
<b>No-Heat Length</b> (Refer to <a href="#">page 279</a> )	1" minimum, 12" maximum (25/305 mm)	1" minimum, 12" maximum (25/305 mm)
<b>Maximum Voltage—Amperage</b>	480V~(ac)—48 amps	480V~(ac)—32 amps
<b>Maximum Hipotential</b>	1960V~(ac)	1960V~(ac)
<b>Maximum Current Leakage (cold)</b>	2 milliamps	2 milliamps
<b>Maximum Amperage Per Coil</b>	16 amps	16 amps
<b>Phase(s)</b>	1-phase parallel/series, 3-phase delta/wye	1-phase parallel/series
<b>Resistance Coils</b>	3 or 2	2
<b>Ohms/Inch/Unit</b> ①	0.270Ω minimum—2.833Ω maximum	0.040Ω minimum—4.250Ω maximum
<b>Ohms/Inch/Coil</b> ①	0.080Ω minimum—8.500Ω maximum per coil	0.080Ω minimum—8.500Ω maximum per coil
<b>Terminations</b>	Flexible lead wires Quick connect (spade) Screw lug (plate) Threaded stud	Flexible lead wires Quick connect (spade) Screw lug (plate) Threaded stud
<b>Seals</b>	Stock: Lavacone 390°F (200°C) M-t-O: Ceramic base 2800°F (1535°C) RTV 500°F (260°C) Lavacone 390°F (200°C) Epoxy resin 250°F (120°C)	Stock: Lavacone 390°F (200°C) M-t-O: Ceramic base 2800°F (1535°C) RTV 500°F (260°C) Lavacone 390°F (200°C) Epoxy resin 250°F (120°C)
<b>Minimum Axis Bending Radius</b> inch (mm) (Do Not Field Bend)	Major: 1 (25) Minor: 1/2 (13) 90° bend Minor: 5/32 (4) 180° bend	Major: 3/4 (19) Minor: 1/2 (13) 90° bend Minor: 5/32 (4) 180° bend
<b>Mounting Options</b>	Brackets (Type 1, 2 and 3) Threaded bulkhead or fitting	Brackets (Type 1, 2 and 3) Threaded bulkhead or fitting
<b>Surface Finish Options</b>	Bright Anneal, Passivation	Bright Anneal, Passivation
<b>Optional Internal Thermocouple</b>	ASTM Type K	—
<b>Agency Recognition</b>	UL® Component recognition to 480V~(ac) (file # E52951) CSA Component recognition to 480V~(ac) (file # 31388)	UL® Component recognition to 480V~(ac) (file # E52951) CSA Component recognition to 480V~(ac) (file # 31388)

① Resistance values valid for three coil 1 inch FIREBAR only.

# Tubular and Process Assemblies

## FIREBAR Heating Elements

### Specifications

#### One Inch Single-Ended FIREBAR

#### 5/8 Inch Single-Ended FIREBAR

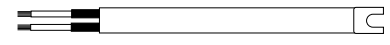
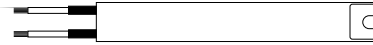

<b>Applications</b>	Clamp-on; hoppers, griddles Forced or convection air heating (Also see FINBAR, <a href="#">page 318</a> )	Clamp-on; hoppers, griddles Forced or convection air heating
<b>Watt Density</b> W/in <sup>2</sup> (W/cm <sup>2</sup> )	Stock: up to 40 (6.2) M-t-O: up to 60 (9.3)	Stock: up to 20 (3.1) M-t-O: up to 60 (12.4)
<b>Surface Area Per Linear Inch (cm)</b>	2.3 in <sup>2</sup> (14.8 cm <sup>2</sup> )	1.52 in <sup>2</sup> (9.80 cm <sup>2</sup> )
<b>Cross Section</b> Height ± 0.015/0.010" (0.381/0.254 mm) Thickness ± 0.005/0.001" (0.127/0.025 mm)	1.010 (25.7) 0.235 (5.9)	0.650 (16.5) 0.235 (5.9)
<b>Sheath Material—Maximum Operating Temperature</b>	Stock: 304 S. Steel 1200°F (650°C) M-t-O: Incoloy® 1400°F (760°C) 304 S. Steel 1200°F (650°C)	Stock: Incoloy® 1400°F (760°C) M-t-O: Incoloy® 1400°F (760°C) 304 S. Steel 1200°F (650°C)
<b>Sheath Length</b> inch (mm)	Stock: 11 to 46 1/4 (280 to 1175) M-t-O: 11 to 120 (280 to 3048)	Stock: 11 1/2 to 52 (280 to 1321) M-t-O: 11 to 116 (280 to 2946)
<b>Straightness Tolerance</b> Major axis inch/foot (cm/m): Minor axis inch/foot (cm/m):	0.062 (0.52) 0.062 (0.52)	0.062 (0.52) 0.062 (0.52)
<b>No-Heat Length</b> (Refer to <a href="#">page 279</a> ) Top Cold End Bottom (blunt end) Cold End	1" min., 12" max. (25/305 mm) 1 ph- 0.5 min., 2" max. (13/51 mm) 3 ph- 0.75 min., 2" max. (19/51 mm)	1" min., 12" max. (25/305 mm) Only available at 1.25" N/A
<b>Maximum Voltage—Amperage</b> <b>Maximum Hipotential</b> <b>Maximum Current Leakage (cold)</b> <b>Maximum Amperage Per Coil</b> <b>Phase(s)</b> <b>Resistance Coils</b>	480V~(ac)—48 amps 1960V~(ac) 2 milliamps 16 amps 1-phase, 3-phase wye 3 or 1	480V~(ac)—25 amps 1960V~(ac) 2 milliamps 16 amps 1-phase 1
<b>Ohms/Inch/Unit</b>	0.200Ω minimum—14.00Ω maximum <sup>Ⓛ</sup>	0.200Ω minimum—14.00Ω maximum <sup>Ⓛ</sup>
<b>Terminations</b>	Flexible lead wires Threaded stud Quick connect (spade) Screw lug (plate)	Flexible lead wires Quick connect (spade) Screw lug (plate)
<b>Seals</b>	Stock: Lavacone 392°F (200°C) M-t-O: Ceramic base 2800°F (1535°C) RTV 500°F (260°C) Lavacone 390°F (200°C) Epoxy resin 266/350°F (130/176°C)	Stock: Lavacone 392°F (200°C) M-t-O: Ceramic base 2800°F (1535°C) RTV 500°F (260°C) Lavacone 390°F (200°C) Epoxy resin 266/350°F (130/176°C)
<b>Minimum Axis Bending Radius</b> inch (mm) (Do Not Field Bend)	Major: 1 (25) Minor: 1/2 (13) 90° bend Minor: 5/32 (4) 180° bend	Major: 3/4 (19) Minor: 1/2 (13) 90° bend Minor: 5/32 (4) 180° bend
<b>Mounting Options</b>	Bracket (Type 2) Threaded bulkhead	Bracket (Type 2) Threaded bulkhead
<b>Surface Finish Options</b>	Bright Anneal	Bright Anneal
<b>Optional Internal Thermocouple</b>	—	—
<b>Single-end Configuration</b>	Stock: Slotted M-t-O: Slotted, sealed or welded	Stock: Slotted M-t-O: Slotted, sealed or welded
<b>Agency Recognition</b>	UL® Component recognition to 480V~(ac) (file # E52951) CSA Component recognition to 480V~(ac) (file # 31388)	UL® Component recognition to 480V~(ac) (file # E52951) CSA Component recognition to 480V~(ac) (file # 31388)

<sup>Ⓛ</sup> Based on 1-phase, single voltage heater.

# Tubular and Process Assemblies

## FIREBAR Heating Elements

### One inch Features and Benefits

#### Double-Ended

- **Streamline, 0.235 X 1.010 inch (5.9 X 25.6 mm) normal to flow dimension** reduces drag.
- **The 70 percent greater surface area per linear inch**, compared to a 0.430 inch (11 mm) diameter round tubular heater, reduces watt density or packs more kilowatts in smaller bundles.
- **Compacted MgO insulation** maximizes thermal conductivity and dielectric strength.
- **Nickel-chromium resistance wires** are precision wound.
- **The 0.040 inch (1 mm) thick MgO walls** more efficiently transfer heat away from the resistance wire to the sheath and media—conducts heat out of the element faster.
- **The 360° fusion welded wire-to-pin connection** ensures reliable electrical connection.
- **Three resistance coil design**, configurable to either one- or three-phase power, readily adapts to a variety of electrical sources and wattage outputs.
- **Lavacone seals** provide protection against humid storage conditions. Moisture retardant to 392°F (200°C).

#### Single-Ended

- **Single-ended termination** simplifies wiring and installation.
- **Streamline, 0.235 X 1.010 inch (5.9 X 25.6 mm) normal to flow dimension** reduces drag.
- **The 70 percent greater surface area per linear inch** reduces the watt density from that of the 0.430 inch (11 mm) diameter round tubular heater.
- **Slotted end** provides installation ease in clamp-on applications.
- **Lavacone seals** provide protection against humid storage conditions. Moisture retardant to 392°F (200°C).

### 5/8 inch Features and Benefits

#### Double-Ended

- **Special sheath dimensions, 0.235 X 0.650 inch (5.9 X 16.5 mm)**, result in a lower profile heater.
- **The 10 percent greater surface area per linear inch** reduce the watt density from that of the 0.430 inch (11 mm) diameter round tubular heater.
- **The 0.040 inch (1 mm) thick MgO walls** efficiently transfer heat away from the resistance wire to the heated media—conducts heat out of the element faster.
- **Lavacone seals** provide protection against humid storage conditions. Moisture retardant to 392°F (200°C).

#### Single-Ended

- **Single-ended termination** simplifies wiring and installation.
- **Special sheath dimensions, 0.235 X 0.650 inch (5.9 X 16.5 mm)**, result in a lower profile heater for more wattage in a smaller package.
- **Slotted end** is supplied for installation ease in clamp-on applications.
- **Lavacone seals** provide protection against humid storage conditions. Moisture retardant to 392°F (200°C).

## Tubular and Process Assemblies

### FIREBAR Heating Elements

#### **FIREBAR Performance Features**

FIREBAR's flat tubular element geometry produces performance features and benefits not possible with traditional round tubular technology. The following describes how and why the FIREBAR is functionally superior for many applications—especially those requiring large wattage with low watt density.

#### **By using the FIREBAR element you can:**

- Lower the element's watt density
- Reduce element size and keep the same watt density
- Increase element life by reducing sheath temperature

#### **Flat Shape Produces Lower Sheath Temperature**

The FIREBAR element operates at a lower sheath temperature than a round tubular element of equal watt density because of three factors.

#### **1) Flat Surface Geometry**

FIREBAR's flat, vertical geometry is streamline. The liquid's flow past the heating element's surface is not impaired by back eddies inherent in the round tubular shape. The FIREBAR's streamline shape results in fluids flowing more freely with more heat carried away from the sheath.



#### **2) Normal to the Flow**

The element's width (thickness) of both one inch and 5/8 inch FIREBAR elements is just 0.235 inch (5.9 mm). Compared to a 0.430 inch (11 mm) round tubular element, this relative thinness further reduces drag on liquids or gases flowing past the heater.

#### **Comparative Widths**

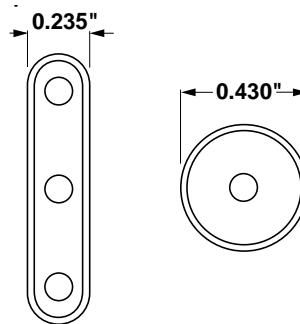

#### **3) Buoyancy Force**

The FIREBAR element's boundary layer, or vertical side, is greater than virtually all round tubular elements. This is 1.010 and 0.650 inches (25.6 and 16.5 mm) for the one inch and 5/8 inch FIREBARs respectively, compared to a 0.430 inch (11 mm) diameter on a round tubular element. The FIREBAR element's increased height, relative to flow, increases the buoyancy force in viscous liquids. This buoyancy force can be as much as 10 times greater depending on the FIREBAR element and liquid used.

#### **Watt Density and Surface Area Advantages**

The surface area per linear inch of a one inch FIREBAR is 70 percent greater than the 0.430 inch (11 mm) diameter round tubular element. And for the 5/8 inch FIREBAR it's nearly 10 percent greater.

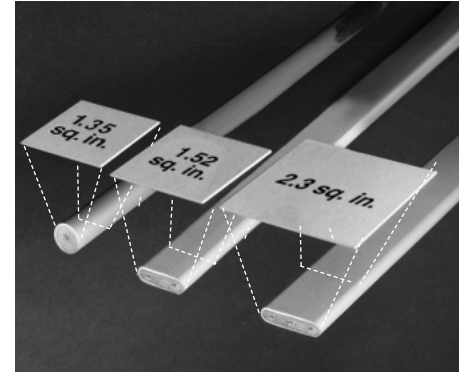

Element Type	Surface Area Per Linear inch (cm)	
	in <sup>2</sup>	(cm <sup>2</sup> )
One inch FIREBAR	2.30 in <sup>2</sup>	(5.84 cm <sup>2</sup> )
5/8 inch FIREBAR	1.52 in <sup>2</sup>	(3.86 cm <sup>2</sup> )
0.430 inch Round	1.35 in <sup>2</sup>	(3.43 cm <sup>2</sup> )

#### **Flat vs. Round Geometry Comparisons**

The unique flat surface geometry of the FIREBAR element offers more versatility in solving heater problems than the conventional round tubular element. The following comparisons show how the FIREBAR element consistently outperforms round tubular heaters. FIREBAR elements can:

- Reduce coking and fluid degrading
- Increase heater power within application space parameters
- Provide superior heat transfer in clamp-on applications resulting from greater surface area contact
- Lower watt density

Reducing watt density or sheath temperature extends life. The FIREBAR element allows you to do either, without sacrificing equipment performance ... as is proven by the accompanying *Heater Oil Test, Air Flow and Watt Density vs. Sheath Temperature* graphs.

# Tubular and Process Assemblies

## FIREBAR Heating Elements

For example, the *FIREBAR Heater Oil Test* graph compares sheath temperatures of 40 W/in<sup>2</sup> (6.7 W/cm<sup>2</sup>) flat and round tubular elements. The FIREBAR element consistently operates at a lower sheath temperature than the round tubular element ... even when light oils are tested at different temperatures. This reduces the chance that coking and fluid degradation will occur.

In fact, the FIREBAR element's sheath temperature at 40 W/in<sup>2</sup> (6.7 W/cm<sup>2</sup>) is lower than a 30 W/in<sup>2</sup> (4.6 W/cm<sup>2</sup>) round tubular element.

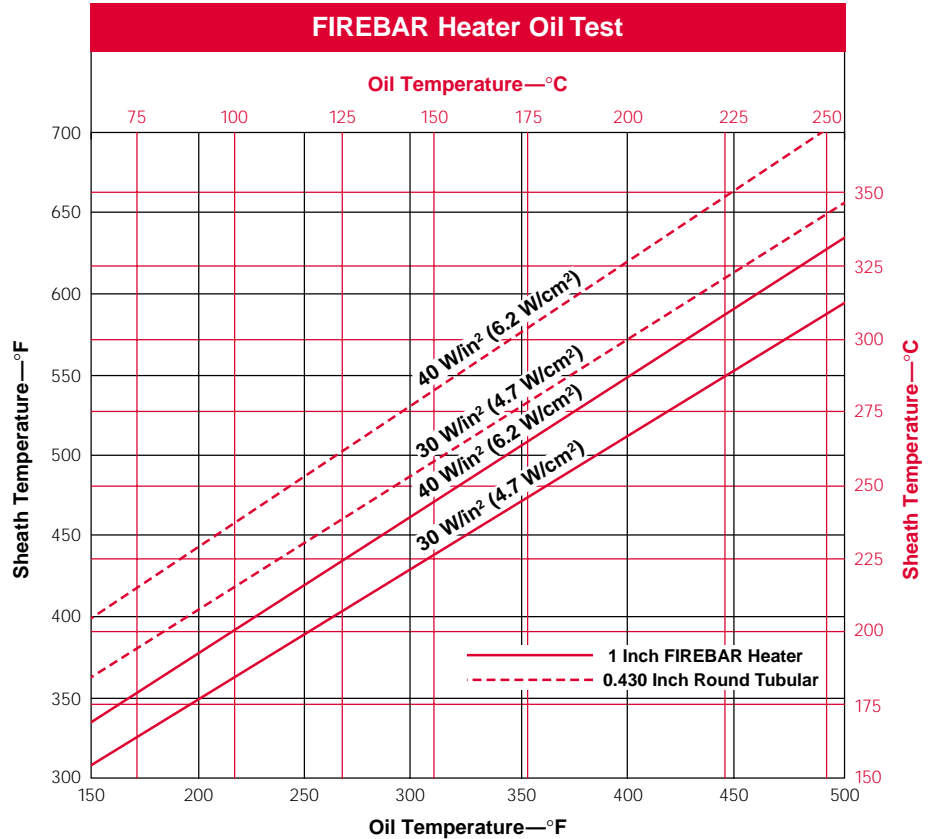

### Heater Size and Power

The *Heater Size Comparison* chart shows, at the same wattage and watt density, the FIREBAR element is 38 percent shorter than a 0.430 inch (11 mm) round tubular element. The FIREBAR element requires less space in application and equipment designs.

The *Heater Power Comparison* chart demonstrates equal watt density, element length and increased total wattage for the FIREBAR element. The power in the FIREBAR element is 70 percent greater.

### Heater Size Comparison

Element	Heated Length inches (mm)	Wattage	W/in <sup>2</sup>	(W/cm <sup>2</sup> )
One inch FIREBAR Element	19 7/8 (505)	1000	23	(3.6)
0.430 inch Round Tubular Element	32 1/4 (820)	1000	23	(3.6)

### Heater Power Comparison

Element	Heated Length inches (mm)	Wattage	W/in <sup>2</sup>	(W/cm <sup>2</sup> )
One inch FIREBAR Element	32 1/4 (820)	1700	23	(3.6)
0.430 inch Round Tubular Element	32 1/4 (820)	1000	23	(3.6)

# Tubular and Process Assemblies

## FIREBAR Heating Elements

### Clamp-On Applications

Direct immersion in the liquid may not always be practical. In these instances the FIREBAR element can be clamped to a tank wall. Heat from the FIREBAR is conducted to the tank wall and into the media.

FIREBAR elements are also economical platen heaters. The *Platen Heating* graph shows FIREBAR's large, flat surface area allows it to operate at twice the watt density of round tubular elements ... without sacrificing heater life.

Clamps should be placed approximately six inches (150 mm) apart and torqued down with 60 in-lbs (6.8 Newton meters).

Platen Heating (°F)

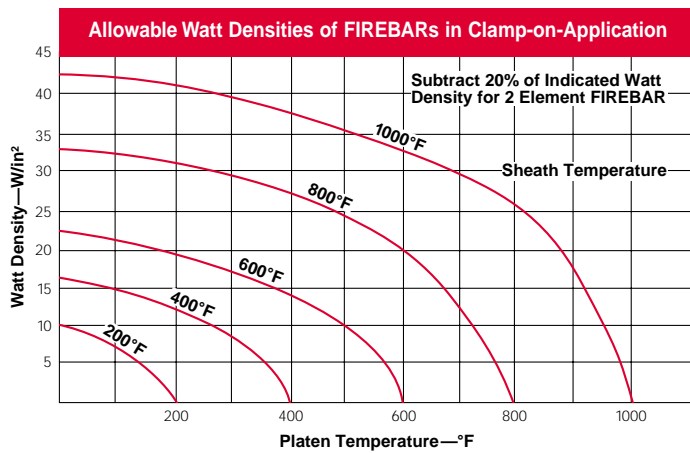

Platen Heating (°C)

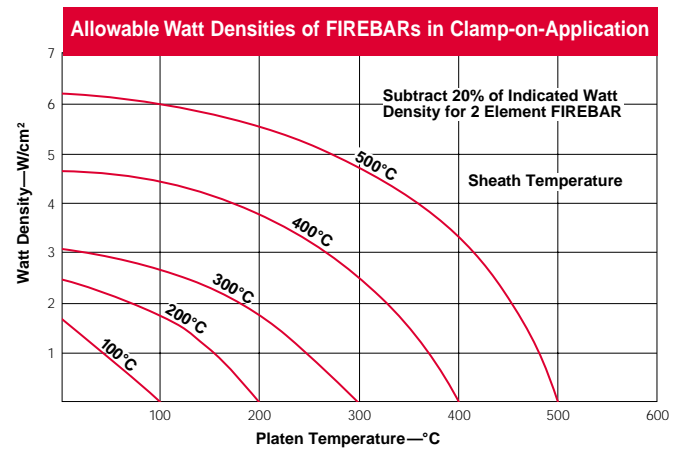

### Watt Density Vs. Sheath Temperature

The *Watt Density vs. Sheath Temperature* graph features sheath temperature curves for commonly heated substances. A FIREBAR element's watt density will result in the sheath temperature shown at the intersecting point of its vertical watt density line and substance curve.

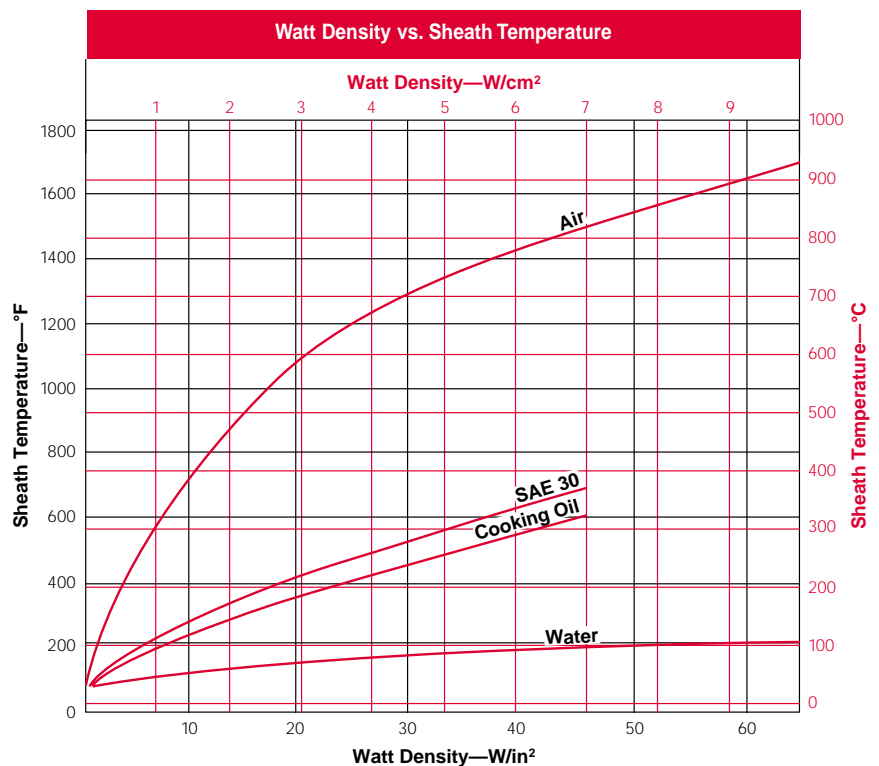

# Tubular and Process Assemblies

## FIREBAR Heating Elements

### Air Heating

The Air Flow/Watt Density/Sheath Temperature graph shows the relationship between air flow, watt density and sheath temperature. Keep in mind that lower sheath temperature yields longer heater life.

To use the Air Flow graph, determine the air flow in feet per second (or meters per second). Then follow the curve to find the recommended sheath temperature and watt density.

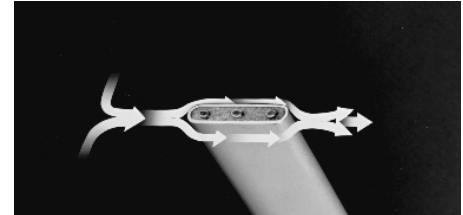

Air flow normal to sheath geometry

**Air Flow/Watt Density/Sheath Temperature (°F)**

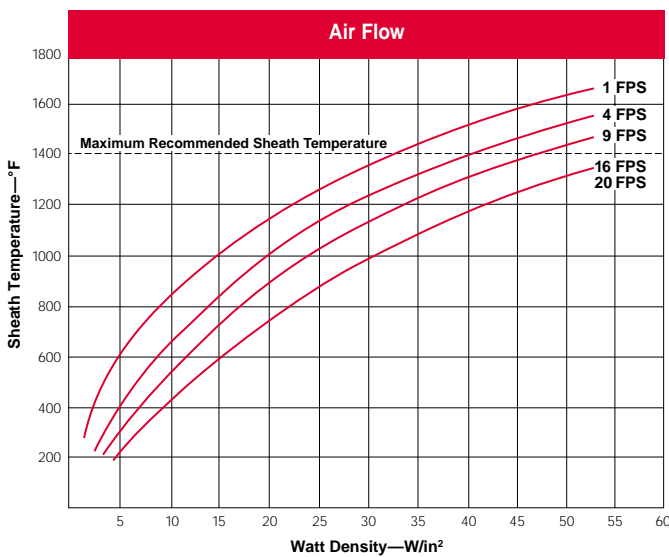

**Air Flow/Watt Density/Sheath Temperature (°C)**

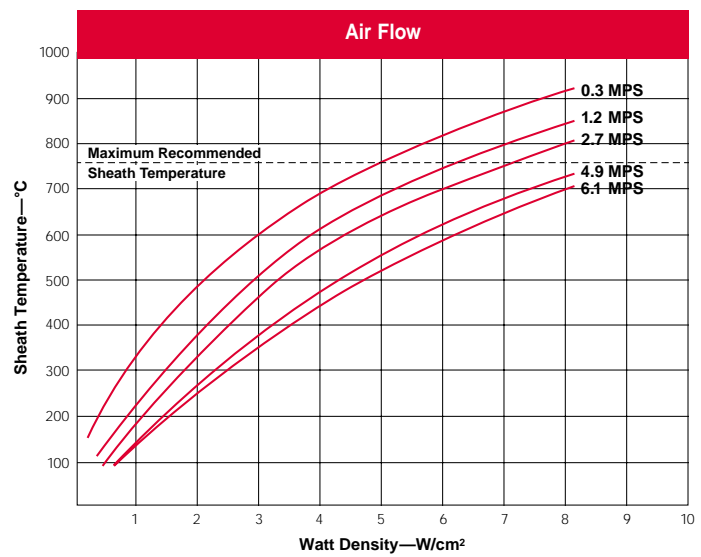

### Moisture Resistant Seals

A standard lavacone seal is provided to prevent moisture and contaminants from entering the heater. Upon request, optional silicone rubber (RTV) and epoxy resin seals may be ordered.

### Silicone Rubber (RTV) Seal

Silicone rubber (RTV) seals are 1/8 inch (3.2 mm) moisture barriers surrounding the terminal pins at the end of the sheath. Silicone rubber is effective to 500°F (260°C).

### Epoxy Resin Seal

Epoxy resin seals are 1/8 inch (3.2 mm) moisture barriers surrounding the terminal pins at the end of the sheath. Epoxy resin is effective to 266°F (130°C) or 350°F (176°C), and recommended for water heating applications.

### Application Hints

- Choose a FIREBAR heating element instead of an assembly, when your application requires lower wattages or smaller system packages.
- Keep terminations clean, dry and tight.
- Extend the heated section completely into the media being heated at all times to maximize heat transfer and heater life.
- Do not locate the end of the heated length within a bend, unless the radius is three inches (76 mm) or larger.
- Ensure termination temperatures do not exceed 392°F (200°C) or the maximum temperature rating of the end seal.

# Tubular and Process Assemblies

## FIREBAR Heating Elements

All FIREBAR heaters are available with a variety of termination options. Consult factory for availability.

### Termination Code Legend

#### Termination Type







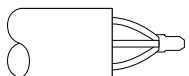
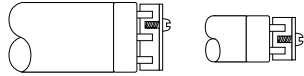
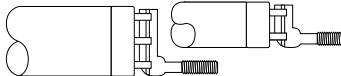
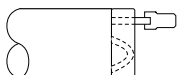

- A = Silicone rubber insulation (Sil-A-Blend™) with fiberglass oversleeves. Rated to 392°F (200°C).
- B = High-temperature TGGT insulation with fiberglass oversleeves. Rated to 480°F (250°C).
- C = Nickel-plated steel quick connect.
- D = Nickel-plated steel screw lug with ceramic insulator and plated steel screw
- E = #10-32 nickel-plated steel threaded stud with plated steel nuts and washers.

#### Electrical Configuration

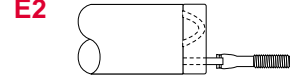
1 = 1-Phase parallel, 2 = 1-Phase series, 3 = 3-Phase delta, 4 = 3-Phase wye

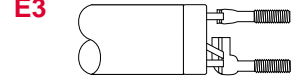
Code No.	Termination	Phase	Wiring	1 Inch FIREBAR		5/8 inch FIREBAR	
				Dual Ended	S. End/FINBAR	Dual Ended	Single Ended
A1	Sil-A-Blend™ 200°C Lead wire	1	Parallel	Yes	Yes	Yes	Yes
A2	Sil-A-Blend™ 200°C Lead wire	1	Series	Yes	No	No	No
A3	Sil-A-Blend™ 200°C Lead wire	3	Delta	Yes	No	No	No
A4	Sil-A-Blend™ 200°C Lead wire	3	Wye	No	Yes	No	No
B1	TGGT 250°C Lead wire	1	Parallel	Yes	Yes	Yes	Yes
B2	TGGT 250°C Lead wire	1	Series	Yes	No	No	No
B3	TGGT 250°C Lead wire	3	Delta	Yes	No	No	No
B4	TGGT 250°C Lead wire	3	Wye	No	Yes	No	No
C1	1/4" Quick Connect (Spade)	1	Parallel	Yes	Yes	Yes	Yes
C2	1/4" Quick Connect (Spade)	1	Series	Yes	No	No	No
D1	Screw Lug (Plate) Terminal	1	Parallel	Yes	Yes	Yes	Yes
D2	Screw Lug (Plate) Terminal	1	Series	Yes	No	No	No
D3	Screw Lug (Plate) Terminal	3	Delta	Yes	No	No	No
E1	#10-32 Stud Terminal	1	Parallel	Yes	Yes	Yes	No
E2	#10-32 Stud Terminal	1	Series	Yes	No	No	No
E3	#10-32 Stud Terminal	3	Delta	Yes	No	No	No

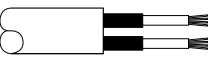
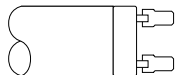
FIREBAR®

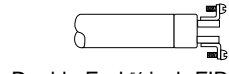
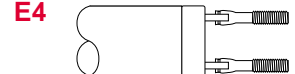
Flexible Lead Wire A, B	Quick Connect (Spade) C1, C2, C3	Screw Lug (Plate) D1, D2, D3, D4	Threaded Stud E1, E2, E3, E4
 <ul style="list-style-type: none"> <li>• Double End 1 inch FIREBAR</li> <li>• Single End 1 inch FIREBAR</li> <li>• FINBAR</li> </ul>	 <ul style="list-style-type: none"> <li>• Double End 1 inch FIREBAR</li> </ul>	 <ul style="list-style-type: none"> <li>• Double End 1 &amp; 5/8 inch FIREBAR</li> </ul>	 <ul style="list-style-type: none"> <li>• Double End 1 &amp; 5/8 inch FIREBAR</li> </ul>
	 <ul style="list-style-type: none"> <li>• Double End 1 inch FIREBAR</li> </ul>	 <ul style="list-style-type: none"> <li>• Double End 1 inch FIREBAR</li> </ul>	 <ul style="list-style-type: none"> <li>• Double End 1 inch FIREBAR</li> </ul>
		 <ul style="list-style-type: none"> <li>• Double End 1 inch FIREBAR</li> </ul> <p>3 Phase delta wiring example </p>	 <ul style="list-style-type: none"> <li>• Double End 1 inch FIREBAR</li> </ul> <p>3 Phase delta wiring example </p>
 <ul style="list-style-type: none"> <li>• Single End 1 inch FIREBAR</li> <li>• Double End 5/8 inch FIREBAR</li> <li>• Single End 5/8 inch FIREBAR</li> <li>• FINBAR</li> </ul>	 <ul style="list-style-type: none"> <li>• Single End 1 FIREBAR</li> <li>• FINBAR</li> </ul> <ul style="list-style-type: none"> <li>• Double End 5/8 inch FIREBAR</li> <li>• Single End 5/8 inch FIREBAR</li> </ul>	 <ul style="list-style-type: none"> <li>• Single End 1 inch FIREBAR</li> <li>• FINBAR</li> </ul>  <ul style="list-style-type: none"> <li>• Double End 5/8 inch FIREBAR</li> <li>• Single End 5/8 inch FIREBAR</li> </ul>	 <ul style="list-style-type: none"> <li>• Single End 1 inch FIREBAR</li> <li>• FINBAR</li> </ul>

① Flexible lead wires are 12 inches (305 mm) long unless otherwise specified. Sil-A-Blend™ is a trademark of Radix Wire Company.

# Tubular and Process Assemblies

## FIREBAR Heating Elements

### Bending

#### Major and Minor Axis Bending Parameters

The following illustrations detail the recommended major and minor axis bend parameters for FIREBAR elements. These illustrations show

the relationship between the type of bend and the location of heat and no-heat sections. See [pages 309 to 310](#) for the 15 common bend formations.

**Note:** Watlow does not recommend field bending FIREBAR elements. If the element must be bent in the field, please consult your Watlow representative for assistance.

**180 degree Minor Axis Heated Bend**

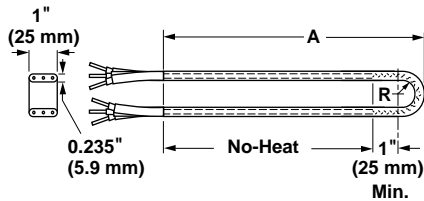

**180 degree Major Axis Heated Bend**

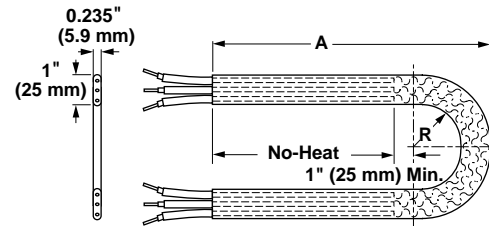

**90 degree Minor Axis Heated Bend**

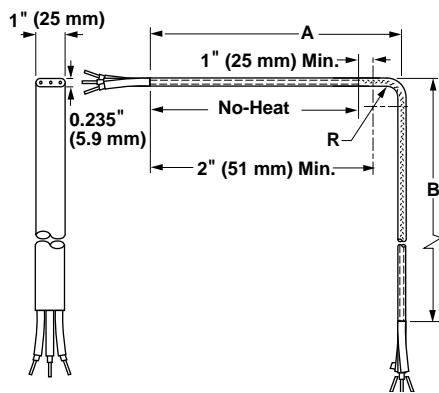

**90 degree Major Axis Heated Bend**

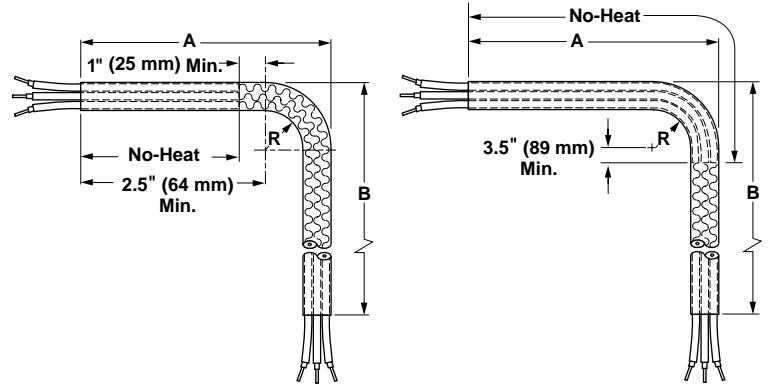

**90 degree Minor Axis Un-Heated Bend**

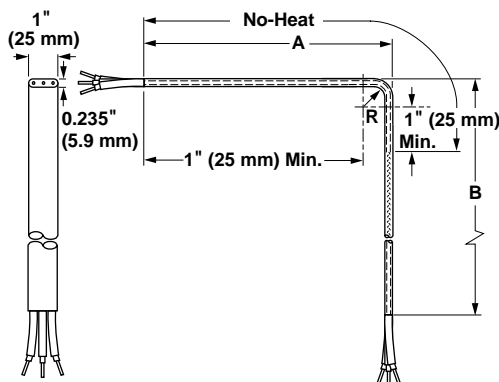

**180 degree Major Axis Bends**

FIREBAR Size		Radius		Arc Length
inch	(mm)	inch	(mm)	
5/8"	(16)	3/4"	(19)	3.125
5/8"	(16)	1"	(25)	3.900
5/8"	(16)	1 1/4"	(32)	4.620
5/8"	(16)	1 1/2"	(38)	5.600
1"	(25)	1"	(25)	4.335
1"	(25)	1 1/4"	(32)	5.121
1"	(25)	1 1/2"	(38)	5.906

# Tubular and Process Assemblies

## FIREBAR Heating Elements

### Bend Formations

FIREBAR elements can be formed into spirals, compounds, multi-axis and multi-plane configurations from 15 common bends. Custom bending with tighter tolerances can be made to meet specific application needs.

Formation is limited by bending parameters specified in the illustrations of major and minor axis

bends on **page 308**. On these illustrations, please note the no-heat end location.

The no-heat end junction must be located a minimum of one inch (25 mm) from any bend. If these parameters are not followed, the heater may fail prematurely.

Illustrated on **pages 309 to 310** are the 15 common bends that can be

ordered for all in-stock and **made-to-order** FIREBAR heating elements.

To order a common bend, specify the **figure number** and **critical dimensions**.

**Note:** The alpha characters and symbols are used to designate specific dimensions within each illustration.

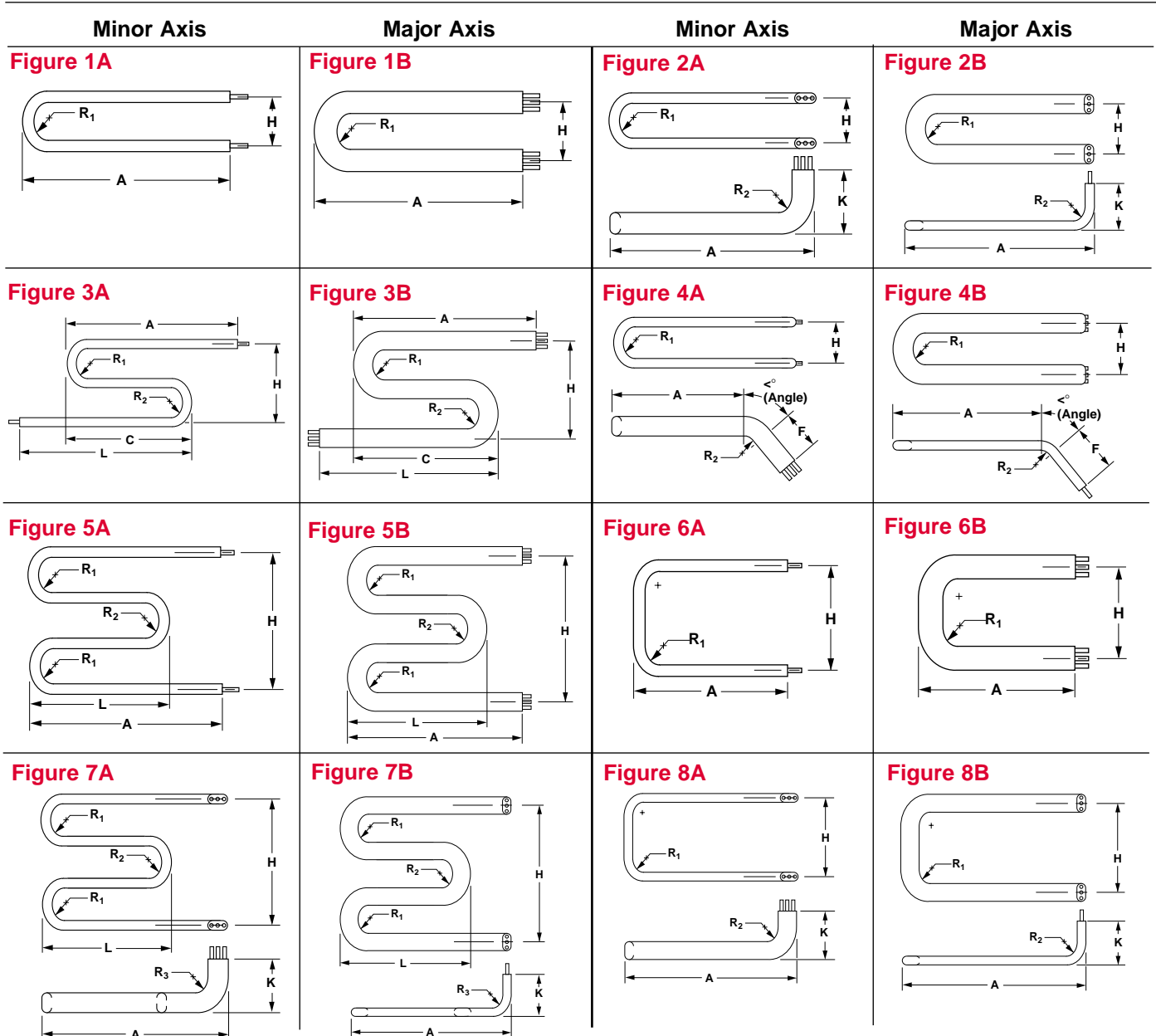

# Tubular and Process Assemblies

## FIREBAR Heating Elements

Minor Axis	Major Axis	Minor Axis	Major Axis
<p><b>Figure 9A</b></p>	<p><b>Figure 9B</b></p>	<p><b>Figure 10A</b></p>	<p>Bend Figure 10B Not Available On Major Axis</p>
<p><b>Figure 11A</b></p>	<p>Bend Figure 11B Not Available On Major Axis</p>	<p><b>Figure 12A</b></p>	<p><b>Figure 12B</b></p>
<p><b>Figure 13A</b></p>	<p><b>Figure 13B</b></p>	<p><b>Figure 14A</b></p>	<p><b>Figure 14B</b></p>
<p><b>Figure 15A</b></p>	<p><b>Figure 15B</b></p>		

## Tubular and Process Assemblies

### FIREBAR Heating Elements

#### Mounting Brackets

Steel brackets provide element mounting in non-pressurized applications. In air heating applications, an 18 gauge aluminized steel bracket is press fitted to the element. A 1/4 inch (6 mm) thick steel bracket is brazed or welded liquid-tight to the element for liquid heating. Upon request, stainless steel brackets can be provided. Special sizes also available.

The bracket is located 1/2 inch (13 mm) from the sheath's end, unless otherwise specified.

Available on 3/8 inch FIREBAR as **made-to-order** only.

To order, specify **mounting bracket** as well as type, location, material and size.

Type 1

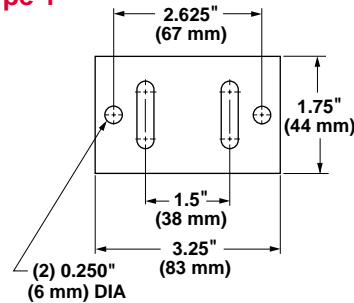

Type 2

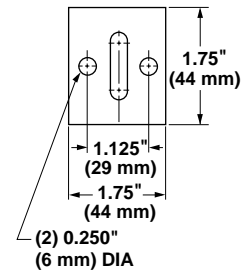

Type 3

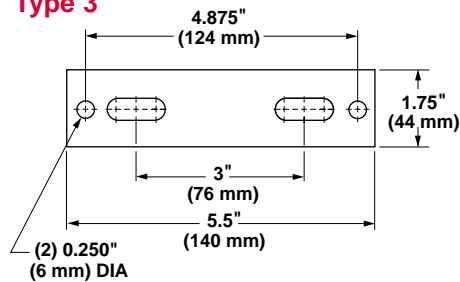

#### Threaded Bulkheads

A threaded stainless steel bushing with flange on the heater sheath provides rigid, leak-proof mounting through tank walls. A gasket, plated steel washer and hex nut are included.

To order, specify **threaded bulkheads**.

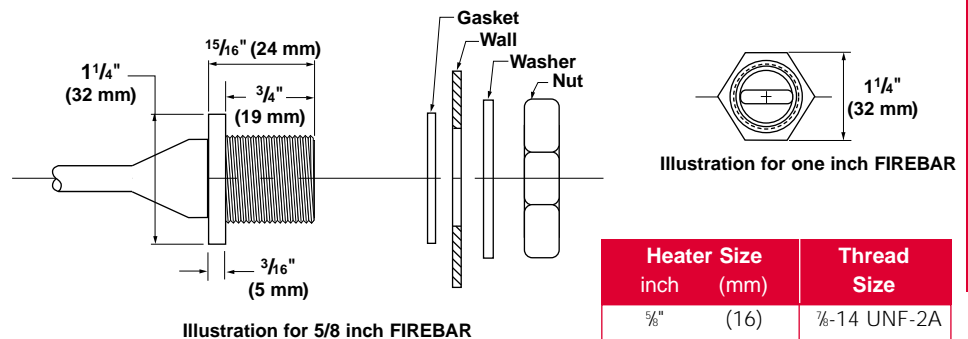

Heater Size inch	Heater Size mm	Thread Size
5/8"	(16)	3/8-14 UNF-2A
1"	(25)	1/2-16 UNF-2A

#### Water-Tight Double Leg Threaded Fitting

A threaded 1 5/8 inch-10 UNC stainless steel fitting with flange on the heater sheath provides rigid, leak-proof mounting through tank walls. This fitting allows both legs of the heater to pass through the same opening. A gasket, plated steel washer and hex nut are included. The threaded end of the bulkhead is mounted flush with the sheath's end, unless otherwise specified. Available on **one inch FIREBAR only**.

To order, specify **water-tight double leg threaded fitting**.

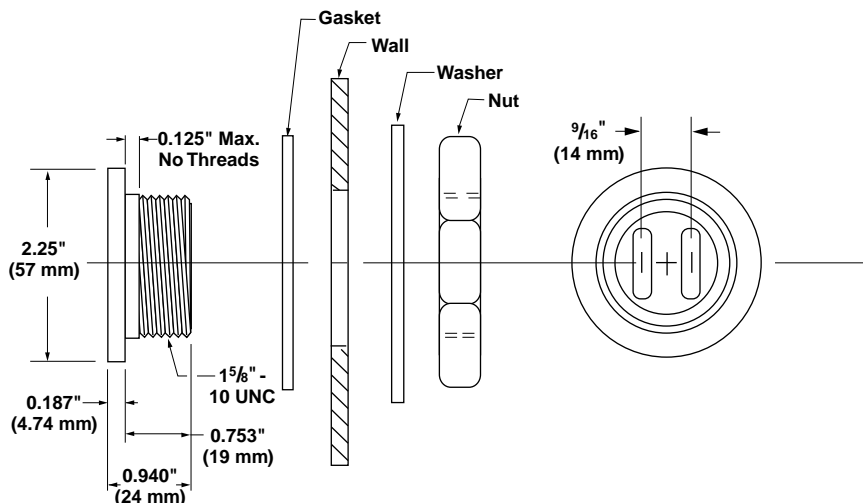

# Tubular and Process Assemblies

## FIREBAR Heating Elements

### Options

Continued

### Surface Finish

#### Bright Annealing

A process that produces a smooth, metallic finish. It is a special annealed finish created in a non-oxidizing atmosphere. This finish is popular in the pharmaceutical and foodservice/beverage markets.

To order, specify **bright annealing**.

#### Passivation

During manufacturing, particles of iron or tool steel may be embedded in the stainless steel or alloy sheath. If not removed, these particles may corrode and produce rust spots. For critical sheath applications, passivation will remove free iron from the sheath.

To order, specify **passivation**.

#### Internal Thermocouples

To provide protection against element over-temperature conditions, one inch single- and double-ended FIREBAR elements can be ordered with ASTM **Type K** thermocouples. This is accomplished by eliminating the center resistance coil and embedding the thermocouple

junction inside the sheath. Thus thermocouples are available only on two resistance coil, one inch FIREBAR elements.

To order, specify:

- **Type K** thermocouple
- Distance the junction is to be located from the element's end
- Lead length

#### Thermocouple Types

ASTM Type	Conductor Positive	Characteristics Negative	Recommended <sup>①</sup> Temperature Range °F (°C)
K	Chromel® (Non-magnetic)	Alumel® (Magnetic)	0 to 2000 (-20 to 1100)

① **Type K** thermocouples are rated 32 to 2282°F (0 to 1250°C). Watlow does not recommend exceeding the temperature range shown on this chart.

Alumel® and Chromel® are registered trademarks of the Hoskins Manufacturing Company.

# Tubular and Process Assemblies

F.O.B.: Hannibal, Missouri

## FIREBAR Heating Elements

### One Inch, Double Ended FIREBAR

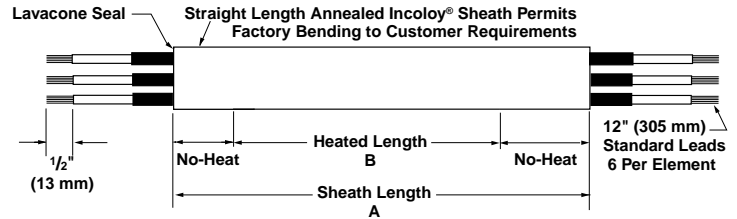

FIREBAR Description	Sheath A Dimension		Heated B Dimension		Watts	Code Number			Est. Net Weight	
	inch	(mm)	inch	(mm)		120V~(ac)	240V~(ac)	480V~(ac)	lbs	(kg)

**Applications: Asphalt, Paraffin (Solid), Bunker Oil, Clamp-On**

6 W/in <sup>2</sup> Incoloy® (1 W/cm <sup>2</sup> )	35	(889)	25	(635)	310	FBN351WD			1.3	(0.6)
	41	(1041)	31	(787)	410	FBN411WD			1.5	(0.7)
	51	(1295)	41	(1041)	530	FBN511WD	FBN5110WD		1.9	(0.9)
	62	(1574)	52	(1320)	650	FBN621WD	FBN6210WD		2.3	(1.1)
	72	(1828)	62	(1574)	800	FBN721WD	FBN7210WD		2.6	(1.2)
	93	(2362)	83	(2108)	1060	FBN931WD	FBN9310WD		3.4	(1.6)
	114	(2895)	104	(2641)	1350	FBN1141WD	FBN11410WD		4.2	(1.9)

**Applications: Griddles, Fuel Oil, Clamp-On**

10 W/in <sup>2</sup> Incoloy® (1.6 W/cm <sup>2</sup> )	25	(635)	22	(558)	500	FBN251WL			0.9	(0.4)
	35	(889)	32	(812)	750	FBN351WL	FBN3510WL		1.3	(0.6)
	47	(1193)	43	(1092)	1000	FBN471WL	FBN4710WL		1.7	(0.8)
	69	(1752)	65	(1651)	1500	FBN691WL	FBN6910WL		2.5	(1.2)
	90	(2286)	86	(2184)	2000	FBN901WL	FBN9010WL		3.3	(1.5)

**Applications: Clamp-On, Medium Weight Oils, Liquid Paraffin, Low Temperature Ovens 400°F (205°C)**

15 W/in <sup>2</sup> ② Incoloy® (2.3 W/cm <sup>2</sup> )	29	(736)	19	(482)	670		FBN2910WE		1.1	(0.5)
	34	(863)	24	(609)	830		FBN3410WE		1.3	(0.6)
	39	(990)	29	(736)	1000		FBN3910WE		1.4	(0.7)
	48	(1219)	38	(965)	1330		FBN4810WE	FBN4811WE	1.8	(0.9)
	58	(1473)	48	(1219)	1670		FBN5810WE	FBN5811WE	2.1	(1.0)
	68	(1727)	58	(1473)	2000		FBN6810WE	FBN6811WE	2.5	(1.2)
	87	(2209)	77	(1955)	2670		FBN8710WE	FBN8711WE	3.2	(1.5)
	106	(2692)	96	(2438)	3330		FBN10610WE	FBN10611WE	3.9	(1.8)

**Applications: Radiant, Platens, Dies, Low Temperature Ovens 300°F (150°C)**

20 W/in <sup>2</sup> Incoloy® (3.1 W/cm <sup>2</sup> )	15	(381)	11	(279)	500	FBN151WM			0.6	(0.3)
	20	(508)	16	(406)	750	FBN201WM			0.8	(0.4)
	26	(660)	22	(558)	1000	FBN261WM	FBN2610WM		1.0	(0.5)
	36	(914)	32	(812)	1500	FBN361WM	FBN3610WM		1.3	(0.6)
	48	(1219)	43	(1092)	2000	FBN481WM	FBN4810WM		1.8	(0.9)
	70	(1778)	65	(1651)	3000		FBN7010WM	FBN7011WM	2.6	(1.2)
	91	(2311)	85	(2159)	4000		FBN9110WM	FBN9111WM	3.3	(1.5)

**Applications: Degreasing Solutions, Heat Transfer Oils**

23 W/in <sup>2</sup> Incoloy® (3.6 W/cm <sup>2</sup> )	35	(889)	25	(635)	1250	FBN351WT	FBN3510WT		1.3	(0.6)
	41	(1041)	31	(787)	1625	FBN411WT	FBN4110WT		1.5	(0.7)
	51	(1295)	41	(1041)	2125	FBN511WT	FBN5110WT	FBN5111WT	1.9	(0.9)
	62	(1574)	52	(1320)	2625	FBN621WT	FBN6210WT	FBN6211WT	2.3	(1.1)
	72	(1828)	62	(1574)	3200	FBN721WT	FBN7210WT	FBN7211WT	2.6	(1.2)
	93	(2362)	83	(2108)	4250	FBN931WT	FBN9310WT	FBN9311WT	3.4	(1.6)
	114	(2895)	104	(2641)	5400	FBN1141WT	FBN11410WT	FBN11411WT	4.2	(1.9)

CONTINUED

All heating elements are Stock units unless otherwise noted.

② Standard

**Availability**

**Stock:** Same day shipment

**Standard:** 10 working days

Truck Shipment only

FIREBAR®

# Tubular and Process Assemblies

## FIREBAR Heating Elements

### One Inch, Double Ended FIREBAR

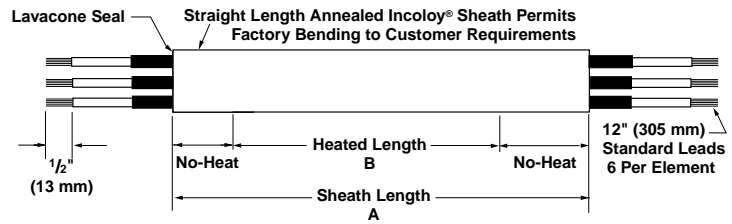

FIREBAR Description	Sheath A Dimension		Heated B Dimension		Watts	Code Number			Est. Net Weight	
	inch	(mm)	inch	(mm)		120V~(ac)	240V~(ac)	480V~(ac)	lbs	(kg)

#### Applications: Cooking Oils, Mild Caustic Solution, Ethylene Glycol (100%)

30 W/in <sup>2</sup> Incoloy® (4.7 W/cm <sup>2</sup> )	16 (406)	10 (254)	750	FBN161WH			0.6 (0.3)
	20 (508)	14 (355)	1000	FBN201WH			0.8 (0.4)
	27 (685)	21 (533)	1500	FBN271WH	FBN2710WH		1.0 (0.5)
	34 (863)	28 (711)	2000	FBN341WH	FBN3410WH		1.3 (0.6)
	50 (1270)	43 (1092)	3000		FBN5010WH	FBN5011WH	1.8 (0.9)
	64 (1625)	57 (1447)	4000		FBN6410WH	FBN6411WH	2.4 (1.1)
80 (2032)	72 (1828)	5000		FBN8010WH	FBN8011WH	2.9 (1.4)	

#### Applications: Process Water, Ethylene Glycol (50%)

40 W/in <sup>2</sup> Incoloy® (6.2 W/cm <sup>2</sup> )	25 (635)	22 (558)	2000		FBN2510WK		0.9 (0.4)
	35 (889)	32 (812)	3000		FBN3510WK	FBN3511WK	1.3 (0.6)
	47 (1193)	43 (1092)	4000		FBN4710WK	FBN4711WK	1.7 (0.8)
	69 (1752)	65 (1651)	6000		FBN6910WK	FBN6911WK	2.5 (1.2)
45 W/in <sup>2</sup> Incoloy® (7 W/cm <sup>2</sup> )	90 (2286)	86 (2184)	8000		FBN9010WK	FBN9011WK	3.3 (1.5)
	29 (736)	19 (482)	2000		FBN2910WP		1.1 (0.5)
	34 (863)	24 (609)	2500		FBN3410WP		1.3 (0.6)
	39 (990)	29 (736)	3000		FBN3910WP		1.4 (0.7)
	48 (1219)	38 (965)	4000		FBN4810WP	FBN4811WP	1.8 (0.9)
	58 (1473)	48 (1219)	5000		FBN5810WP	FBN5811WP	2.1 (1.0)
	68 (1727)	58 (1473)	6000		FBN6810WP	FBN6811WP	2.5 (1.2)
	87 (2209)	77 (1955)	8000		FBN8710WP	FBN8711WP	3.2 (1.5)
	106 (2692)	96 (2438)	10,000		FBN10610WP	FBN10611WP	3.9 (1.8)

#### Applications: Clean and Potable Water

80 W/in <sup>2</sup> Incoloy® (12.4 W/cm <sup>2</sup> )	15 (381)	11 (279)	2000		FBN1510WJ		0.6 (0.3)
	20 (508)	16 (406)	3000		FBN2010WJ		0.8 (0.4)
	26 (660)	22 (558)	4000		FBN2610WJ	FBN2611WJ	1.0 (0.5)
	36 (914)	32 (812)	6000		FBN3610WJ	FBN3611WJ	1.3 (0.6)
	48 (1219)	43 (1092)	8000		FBN4810WJ	FBN4811WJ	1.8 (0.9)
	70 (1778)	65 (1651)	12,000			FBN7011WJ	2.6 (1.2)
90 W/in <sup>2</sup> Incoloy® (14 W/cm <sup>2</sup> )	91 (2311)	85 (2159)	16,000			FBN9111WJ	3.3 (1.5)
	35 (889)	25 (635)	5000	FBN351WG	FBN3510WG	FBN3511WG	1.3 (0.6)
	41 (1041)	31 (787)	6500	FBN411WG <sup>①</sup>	FBN4110WG	FBN4111WG	1.5 (0.7)
	51 (1295)	41 (1041)	8500		FBN5110WG	FBN5111WG	1.9 (0.9)
	62 (1574)	52 (1320)	10,500		FBN6210WG	FBN6211WG	2.3 (1.1)
	72 (1828)	62 (1574)	12,750		FBN7210WG	FBN7211WG	2.6 (1.2)
	93 (2362)	83 (2108)	17,000			FBN931WG	3.4 (1.6)
	114 (2895)	104 (2641)	21,500			FBN11411WG	3.4 (1.6)

All heating elements are Stock units unless otherwise noted.

① Standard

#### Availability

**Stock:** Same day shipment

**Standard:** 10 working days

Truck Shipment only

# Tubular and Process Assemblies

## FIREBAR Heating Elements

### 5/8 Inch, Double Ended FIREBAR

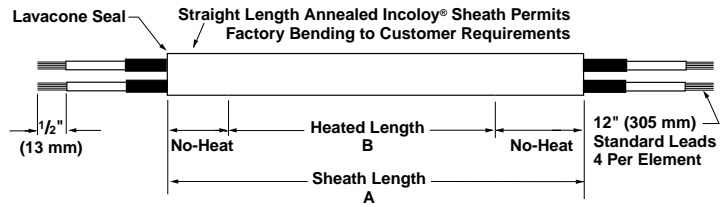

FIREBAR Description	Sheath A Dimension		Heated B Dimension		Watts	Code Number			Est. Net Weight	
	inch	(mm)	inch	(mm)		120V~(ac)	240V~(ac)	480V~(ac)	lbs	(kg)

#### Applications: Degreasing Fluids, Heat Transfer Oils

<b>23 W/in<sup>2</sup></b> ② <b>Incoloy®</b> (3.6 W/cm <sup>2</sup> )	19	(483)	11	(279)	375	<b>FAN191WT</b>			0.5	(0.3)
	22	(559)	14	(356)	500	<b>FAN221WT</b>	<b>FAN2210WT</b>		0.5	(0.3)
	26	(660)	18	(457)	625	<b>FAN261WT</b>	<b>FAN2610WT</b>		0.6	(0.3)
	30	(762)	22	(559)	750	<b>FAN301WT</b>	<b>FAN3010WT</b>		0.7	(0.4)
	37	(940)	29	(737)	1000	<b>FAN371WT</b>	<b>FAN3710WT</b>		0.9	(0.5)
	44	(1118)	36	(914)	1250	<b>FAN441WT</b>	<b>FAN4410WT</b>		1.0	(0.5)
	51	(1295)	43	(1092)	1500	<b>FAN511WT</b>	<b>FAN5110WT</b>		1.2	(0.6)

#### Applications: Clean and Potable Water

<b>90 W/in<sup>2</sup></b> <b>Incoloy®</b> (14 W/cm <sup>2</sup> )	15	(381)	7	(178)	1000	<b>FAN151WG</b> ②	<b>FAN1510WG</b>		0.4	(0.2)
	19	(483)	11	(279)	1500	<b>FAN191WG</b>	<b>FAN1910WG</b> ②	<b>FAN1911WG</b>	0.5	(0.3)
	22	(559)	14	(356)	2000	<b>FAN221WG</b>	<b>FAN2210WG</b> ②	<b>FAN2211WG</b>	0.5	(0.3)
	26	(660)	18	(457)	2500	<b>FAN261WG</b>	<b>FAN2610WG</b> ②	<b>FAN2611WG</b>	0.6	(0.3)
	30	(762)	22	(559)	3000	<b>FAN301WG</b> ②	<b>FAN3010WG</b> ②	<b>FAN3011WG</b>	0.7	(0.4)
	37	(940)	29	(737)	4000		<b>FAN3710WG</b> ②	<b>FAN3711WG</b>	0.9	(0.5)
	44	(1118)	36	(914)	5000		<b>FAN4410WG</b> ②	<b>FAN4411WG</b>	1.0	(0.5)
	51	(1295)	43	(1092)	6000		<b>FAN5110WG</b> ②	<b>FAN5111WG</b>	1.2	(0.6)

All heating elements are Stock units.

② Stock

#### Availability

**Stock:** Same day shipment

**Standard:** 10 working days

# Tubular and Process Assemblies

## FIREBAR Heating Elements

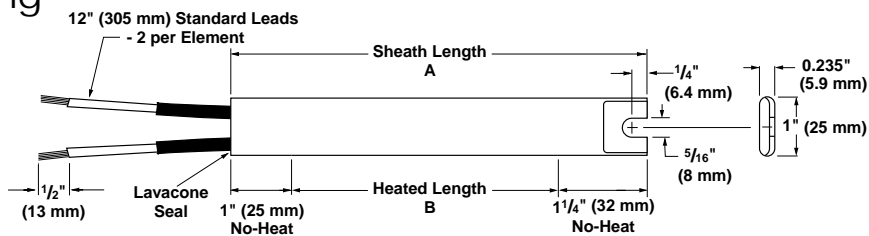

### One Inch, Single Ended FIREBAR

FIREBAR Description	Sheath A Dimension		Heated B Dimension		Watts	Code Number		Est. Net Weight	
	inch	(mm)	inch	(mm)		120V~(ac)	240V~(ac)	lbs	(kg)

Applications: Radiant, Platens, Dies, Low Temperature Ovens 300°F (150°C)

20 W/in <sup>2</sup> 304 SS (3.1 W/cm <sup>2</sup> )	8 3/4	(222)	6 1/2	(165)	300	FSP91WM		0.4	(0.2)
	10 1/4	(260)	7 1/2	(203)	375	FSP101WM		0.4	(0.2)
	12 1/4	(311)	10	(254)	450	FSP121WM		0.5	(0.3)
	13 1/2	(342)	11 1/4	(285)	500	FSP141WM		0.5	(0.3)
	16 1/4	(408)	13 3/8	(352)	650	FSP161WM	FSP1610WM	0.6	(0.3)
	17 3/4	(450)	15 1/2	(393)	725	FSP181WM	FSP1810WM	0.7	(0.4)
	19 1/4	(489)	17	(431)	800	FSP191WM	FSP1910WM	0.7	(0.4)
	22	(558)	19 3/4	(501)	900	FSP221WM	FSP2210WM	0.8	(0.4)
	23 3/4	(603)	21 1/2	(546)	1000	FSP241WM	FSP2410WM	0.9	(0.4)
	25	(635)	22 3/4	(577)	1050	FSP251WM	FSP2510WM	0.9	(0.4)
	28 3/8	(727)	26 3/8	(669)	1250	FSP291WM	FSP2910WM	1.1	(0.5)
	31 3/8	(803)	29 3/8	(746)	1350	FSP321WM	FSP3210WM	1.2	(0.6)
	34 3/8	(865)	31 3/8	(809)	1500		FSP3410WM	1.3	(0.6)
	36 3/8	(936)	34 3/8	(879)	1600		FSP3710WM	1.4	(0.7)
	40 3/8	(1031)	38 3/8	(974)	1800		FSP4110WM	1.5	(0.7)
	46 1/4	(1174)	44	(1117)	2000		FSP4610WM	1.7	(0.8)

Applications: Process Water, Ethylene Glycol (50%)

40 W/in <sup>2</sup> 304 SS (6.2 W/cm <sup>2</sup> )	8 3/4	(222)	6 1/2	(165)	600	FSP91WK		0.4	(0.2)
	10 1/4	(260)	7 1/2	(203)	750	FSP101WK		0.4	(0.2)
	12 1/4	(311)	10	(254)	900	FSP121WK	FSP1210WK	0.5	(0.3)
	13 1/2	(342)	11 1/4	(285)	1000	FSP131WK	FSP1310WK	0.5	(0.3)
	16 1/4	(408)	13 3/8	(352)	1300	FSP161WK	FSP1610WK	0.6	(0.3)
	17 3/4	(450)	15 1/2	(393)	1450	FSP181WK	FSP1810WK	0.7	(0.4)
	19 1/4	(489)	17	(431)	1600		FSP1910WK	0.7	(0.4)
	22	(558)	19 3/4	(501)	1800		FSP2210WK	0.8	(0.4)
	23 3/4	(603)	21 1/2	(546)	2000		FSP2410WK	0.9	(0.4)
	25	(635)	22 3/4	(577)	2100		FSP2510WK	0.9	(0.4)
	28 3/8	(727)	26 3/8	(669)	2500		FSP2910WK	1.1	(0.5)
	31 3/8	(803)	29 3/8	(746)	2700		FSP3210WK	1.2	(0.6)
	34 3/8	(865)	31 3/8	(809)	3000		FSP3410WK	1.3	(0.6)
	36 3/8	(936)	34 3/8	(879)	3200		FSP3710WK	1.4	(0.7)
	40 3/8	(1031)	38 3/8	(974)	3600		FSP4110WK	1.5	(0.7)
	46 1/4	(1174)	44	(1117)	4000		FSP4610WK	1.7	(0.8)

All heating elements are Stock units.

#### Availability

Stock: Same day shipment

# Tubular and Process Assemblies

## FIREBAR Heating Elements

### 5/8 Inch, Single Ended FIREBAR

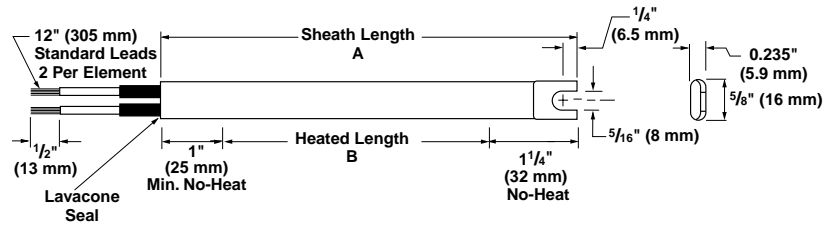

FIREBAR Description	Sheath A Dimension		Heated B Dimension		Watts	Code Number		Est. Net Weight	
	inch	(mm)	inch	(mm)		120V~(ac)	240V~(ac)	lbs	(kg)

Applications: Radiant, Platens, Dies, Low Temperature Ovens 300°F (150°C)

20 W/in <sup>2</sup>	11 1/2	(292)	8	(203)	250	FSA121WM <sup>①</sup>		0.3	(0.2)
Incoloy® (3.1 W/cm <sup>2</sup> )	15 1/2	(394)	12	(304)	375	FSA161WM	FSA1610WM	0.4	(0.2)
	19 1/2	(495)	16	(406)	500	FSA201WM	FSA2010WM <sup>①</sup>	0.5	(0.3)
	28	(711)	24	(609)	750	FSA281WM <sup>①</sup>	FSA2810WM <sup>①</sup>	0.6	(0.3)
	36	(914)	32	(812)	1000	FSA361WM	FSA3610WM	0.8	(0.4)
	52	(1321)	48	(1219)	1500	FSA521WM	FSA5210WM <sup>①</sup>	1.2	(0.6)

**Availability**

**Stock:** Same day shipment

**Standard:** 10 working days

<sup>①</sup> Stock

F.O.B.: Hannibal, Missouri

**How to Order**

To order a stock FIREBAR heating element, specify:

- Watlow code number
- Size (one or 5/8 inch)
- Type (single- or double-ended)
- Volts/watts
- Termination options
- Options
- Quantity

If our stock units do not meet your application needs, Watlow can provide a **made-to-order** unit, please specify:

- Type of application, including heated material, operating temperature, etc.
- Size (one or 5/8 inch)
- Type (single- or double-ended)
- Volts/watts
- Sheath length and material
- Heated length
- No-heat length

- Terminal pin length or termination options
- Moisture seal
- Bend configuration—including dimensions, critical tolerances, major and minor axis bends (please send drawing, if available)
- Options, including external finish and mounting method
- Quantity

**Availability**

**One and 5/8 Inch Double Ended**

**Straight Length Element**

**Stock:** Same day shipment

**Modified Stock<sup>①</sup>:** Three to five working days

**Standard:** Three weeks

**Made-to-Order:** Four to five weeks

**Formed Element**

**Modified Stock<sup>①</sup>:** Five to seven working days

**Standard:** Three weeks

**Made-to-Order:** Four to five weeks

**One and 5/8 Inch Single Ended Straight Length Element**

**Stock:** Same day shipment

**Modified Stock<sup>①</sup>:** Three working days

**Made-to-Order:** Four to five weeks

**Formed Element**

**Modified Stock<sup>①</sup>:** Three working days

**Made-to-Order:** Four to five weeks

Options, complexity and quantity may affect availability and lead times. Consult factory.

<sup>①</sup> Stock units with catalog options.

# Tubular and Process Assemblies

## FIREBAR Heating Elements

### FINBAR

Composed of aluminized steel fins press fitted to a one inch single-ended FIREBAR element. The FINBAR is designed to improve heat transfer to the air and permits putting more power in tighter spaces—like forced air ducts, dryers, ovens and load bank resistors.

Heat transfer, lower sheath temperature and element life are all maximized by its finned construction.

Installation is simplified by terminations exiting at one end and mounting accommodations on both ends.

#### Performance Capabilities

- Watt densities to 50 W/in<sup>2</sup> (7.7 W/cm<sup>2</sup>)
- 304 stainless steel sheath temperatures to 1200°F (650°C)
- Voltages to 480V~(ac)
- Amperages to 48 amps per heater or 16 amps per coil

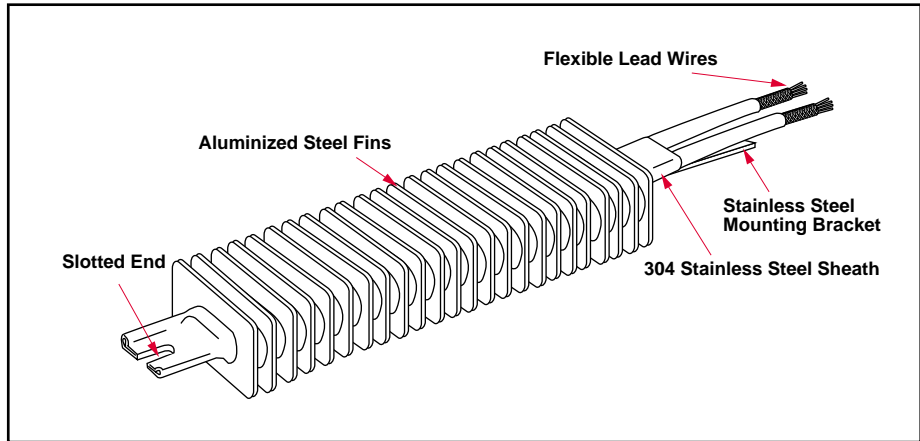

#### Features and Benefits

- **Rugged aluminized steel fins** effectively increase surface area to approximately 16 square inches for every linear inch of element length. Fins press fitted to the heating element improve heat transfer to the air.
- **Single-ended termination** simplifies wiring and installation.
- **Stainless steel mounting bracket**, welded to the terminal end, is supplied with a slotted end for ease of installation.
- **Lavacone seals** provide protection against humid storage conditions. Moisture retardant to 392°F (200°C).

#### Applications

- Forced air heating for dryers, ovens, ducts
- Still air heating for ovens, comfort heating
- Incubators
- Ink drying
- Load bank resistors

#### Construction Features

Construction features are detailed for assembly stock products only. Optional materials, sizes, terminations and ratings may be available at additional cost. For availability and ordering information on options, see [pages 307 to 312](#).

**Watt Density:** Stock; up to 40 W/in<sup>2</sup> (6.2 W/cm<sup>2</sup>), made-to-order; up to 50 W/in<sup>2</sup> (7.7 W/cm<sup>2</sup>)

**Fin Surface Area:** 16 in<sup>2</sup>/linear inch (40.5 cm<sup>2</sup>/linear cm)

**Fin Cross Section:** 2 X 1 inch (50 X 25 mm)

**Maximum Operating Temperature:** Sheath material: 304 Stainless Steel, 1200°F (650°C), Fin material; Aluminized Steel; 1100°F (600°C)

**Heater Length:** Stock; 10 to 48 inches (260 to 1210 mm), made-to-order; 6 to 120 inches (150 to 3050 mm)

**No-Heat Length:** 1 inch minimum, 12 inch maximum (25/305 mm)

**Voltages:** Up to 480V~(ac)

**Phase:** Stock; 1-phase parallel made-to-order; 1-phase parallel or 3-phase wye

**Resistance Coils:** Stock; 1 made-to-order 1 or 3

**Terminations:** Flexible lead wires, quick connect (spade), screw lug (plate) and threaded stud

**Seal Material:** Lavacone, rated to 392°F (200°C)

**Optional Internal Thermocouple:** made-to-order only; ASTM **Type K**

**Single-End Configuration:** Stock; slotted, made-to-order; slotted, no-slot or sealed

**Agency Recognition:** refer to FIREBAR UL file # E52951 and CSA file # 31388 under **Agency Recognition** on [pages 268 to 271](#).

# Tubular and Process Assemblies

## FIREBAR Heating Elements

### Air Heating

The *Watt Density, Air Flow and Sheath Temperature* graph shows the relationship between watt density, air flow velocity and sheath temperature, along with a recommended temperature to avoid deteriorating the fins. Be aware that **lower sheath temperature yields longer heater life.**

The graphic representation is based on a single-ended FINBAR, various air velocities (at 68°F/20°C inlet temperature) and different watt densities.

To determine, from the graph, the operating temperature of the FINBAR's sheath, identify the air velocity curve that approximates

your application in feet per second (meters per second). Then look at the vertical line that most closely approximates the FINBAR's watt density. From the intersecting point, read over to the temperature column to determine the sheath's operating temperature.

Watt Density, Air Flow and Sheath Temperature (°F)

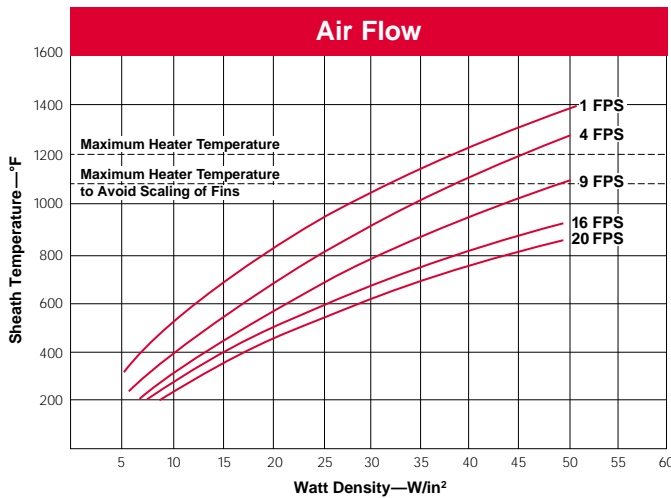

Watt Density, Air Flow and Sheath Temperature (°C)

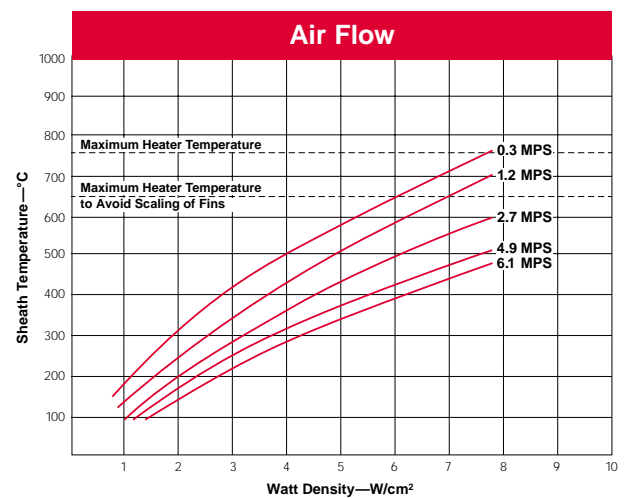

### Application Hints

- Avoid deteriorating the fins by not exceeding the recommended maximum fin temperature of 1100°F (600°C).
- Ensure proper air flow to prevent premature heater failure.
- Locate the temperature sensor downstream from heater(s) for process temperature sensing.

The following mounting parameters are recommended:

- Air flow over element must be parallel with the flat side.
- Element center line to element center line spacing must be a minimum of 1½ inches (38 mm).

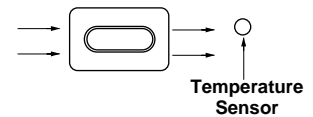

Proper air flow relative to the heater's sheath is parallel with the longer cross sectional axis.

### Dual Ended FINBAR

FINBAR elements are typically terminated at one end. Upon request, however, dual ended

FINBAR heaters can be ordered. To order, specify **dual ended FINBAR** and lead length.



# Tubular and Process Assemblies

## FIREBAR Heating Elements

### FINBAR

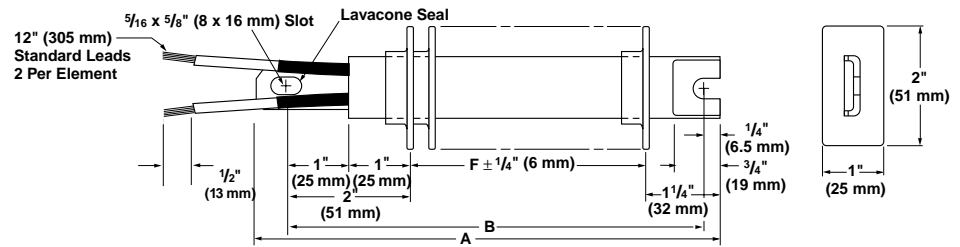

FINBAR Description	Overall A Dimension		Overall F Dimension		Mounting B Dimension		Watts	Code Number		Est. Net Weight	
	Inch	(mm)	Inch	(mm)	Inch	(mm)		120V~(ac)	240V~(ac)	lbs	(kg)

### Application: Forced Air

<b>20 W/in<sup>2</sup></b> <b>304 SS</b> (3.1 W/cm <sup>2</sup> )	10 3/4	(260)	6 1/2	(158)	9 1/2	(241)	300	<b>FSP91WMF</b>		1.4	(0.7)
	11 3/4	(298)	8	(203)	11	(279)	375	<b>FSP101WMF</b>		1.4	(0.7)
	13 3/4	(349)	10	(254)	13	(330)	450	<b>FSP121WMF</b>		1.5	(0.7)
	15	(381)	11 1/4	(285)	14 1/4	(362)	500	<b>FSP141WMF</b>		1.5	(0.7)
	17 3/4	(447)	13 3/8	(352)	16 3/8	(428)	650	<b>FSP161WMF</b>	<b>FSP1610WMF</b>	1.6	(0.8)
	19 3/4	(489)	15 1/2	(393)	18 1/2	(469)	725	<b>FSP181WMF</b>	<b>FSP1810WMF</b>	1.7	(0.8)
	20 3/4	(527)	17	(431)	20	(508)	800	<b>FSP191WMF</b>	<b>FSP1910WMF</b>	1.7	(0.8)
	23 1/2	(597)	19 3/4	(501)	22 3/4	(577)	900	<b>FSP221WMF</b>	<b>FSP2210WMF</b>	1.8	(0.9)
	25 1/4	(641)	21 1/2	(546)	24 1/2	(622)	1000	<b>FSP241WMF</b>	<b>FSP2410WMF</b>	1.9	(0.9)
	26 1/2	(673)	22 3/4	(577)	25 3/4	(654)	1050	<b>FSP251WMF</b>	<b>FSP2510WMF</b>	1.9	(0.9)
	30 3/8	(765)	26 3/8	(669)	29 3/8	(746)	1250	<b>FSP291WMF</b>	<b>FSP2910WMF</b>	2.1	(1.0)
	33 3/8	(841)	29 3/8	(746)	32 3/8	(822)	1350	<b>FSP321WMF</b>	<b>FSP3210WMF</b>	2.2	(1.0)
	35 3/8	(905)	31 3/8	(809)	34 3/8	(885)	1500		<b>FSP3410WMF</b>	2.3	(1.1)
	38 3/8	(975)	34 3/8	(879)	37 3/8	(955)	1600		<b>FSP3710WMF</b>	2.4	(1.1)
42 3/8	(1070)	38 3/8	(974)	41 3/8	(1050)	1800		<b>FSP4110WMF</b>	2.5	(1.2)	
47 3/8	(1213)	44	(1117)	47	(1193)	2000		<b>FSP4610WMF</b>	2.7	(1.3)	
<b>40 W/in<sup>2</sup></b> <b>304 SS</b> (6.2 W/cm <sup>2</sup> )	10 3/4	(260)	6 1/2	(158)	9 1/2	(241)	600	<b>FSP91WKF</b>		1.4	(0.7)
	11 3/4	(298)	8	(203)	11	(279)	750	<b>FSP101WKF</b>		1.4	(0.7)
	13 3/4	(349)	10	(254)	13	(330)	900	<b>FSP121WKF</b>	<b>FSP1210WKF</b>	1.5	(0.7)
	15	(381)	11 1/4	(285)	14 1/4	(362)	1000	<b>FSP131WKF</b>	<b>FSP1310WKF</b>	1.5	(0.7)
	17 3/4	(447)	13 3/8	(352)	16 3/8	(428)	1300	<b>FSP161WKF</b>	<b>FSP1610WKF</b>	1.6	(0.8)
	19 3/4	(489)	15 1/2	(393)	18 1/2	(469)	1450	<b>FSP181WKF</b>	<b>FSP1810WKF</b>	1.7	(0.8)
	20 3/4	(527)	17	(431)	20	(508)	1600		<b>FSP1910WKF</b>	1.7	(0.8)
	23 1/2	(597)	19 3/4	(501)	22 3/4	(577)	1800		<b>FSP2210WKF</b>	1.8	(0.9)
	25 1/4	(641)	21 1/2	(546)	24 1/2	(622)	2000		<b>FSP2410WKF</b>	1.9	(0.9)
	26 1/2	(673)	22 3/4	(577)	25 3/4	(654)	2100		<b>FSP2510WKF</b>	1.9	(0.9)
	30 3/8	(765)	26 3/8	(669)	29 3/8	(746)	2500		<b>FSP2910WKF</b>	2.1	(1.0)
	33 3/8	(841)	29 3/8	(746)	32 3/8	(822)	2700		<b>FSP3210WKF</b>	2.2	(1.0)
	35 3/8	(905)	31 3/8	(809)	34 3/8	(885)	3000		<b>FSP3410WKF</b>	2.3	(1.1)
	38 3/8	(975)	34 3/8	(879)	37 3/8	(955)	3200		<b>FSP3710WKF</b>	2.4	(1.1)
42 3/8	(1070)	38 3/8	(974)	41 3/8	(1050)	3600		<b>FSP4110WKF</b>	2.5	(1.2)	
47 3/8	(1213)	44	(1117)	47	(1193)	4000		<b>FSP4610WKF</b>	2.7	(1.3)	

All stock units are Assembly stock.

### Availability

**Assembly Stock:** Three working days

**F.O.B.: Hannibal, Missouri**

### How to Order

To order a stock FINBAR heating element, specify:

- Watlow Code number
- Volts/watts
- Termination options
- Options
- Quantity

For **made-to-order** FINBAR heating elements, specify:

- Type of application, including air flow velocity, volume, etc.
- Single- or double-ended element
- Volts/watts
- Heated length
- No-heat length
- Terminal pin length or termination options, including moisture seal type
- Quantity

- Options, including thermocouple, sealed end, no mounting bracket, etc.

### Availability

**Assembly Stock:** Three working days

**Modified Stock**®: Five to seven working days

**Made-to-Order:** Four to five weeks

Options, complexity and quantity may affect availability and lead times. Consult factory.

① Assembly Stock units with catalog options.

# Tubular and Process Assemblies

## Quick Ship

- On stock chart units:
- Same day on most heaters
  - 10 working days on special voltages and/or wattages
  - 15 working days on special element lengths

### Screw Plug Immersion Heaters

Screw plug immersion heaters are ideal for direct immersion heating of liquids, including all types of oils and heat transfer solutions.

Available in a variety of stock and made-to-order sizes, Watlow screw plug immersion heaters feature both WATROD round and FIREBAR® flat tubular elements.

Heating elements are hairpin bent and either welded or brazed into the screw plug—depending on element sheath and plug material compatibility.

General purpose (NEMA 1) terminal enclosures are standard; with optional moisture resistant (NEMA 4), explosion resistant (NEMA 7) and explosion/moisture resistant (NEMA 7/4) enclosures available to meet specific application needs.

Optional thermostats provide convenient process temperature regulation.

#### Performance Capabilities

- Watt densities to 120 W/in<sup>2</sup> (18.6 W/cm<sup>2</sup>)
- Wattages to 38kW
- UL® and CSA component recognition to 480V~(ac) and 600V~(ac) respectively
- Incoloy® sheath temperatures to 1600°F (870°C)
- Passivated 316 stainless steel sheath temperatures to 1200°F (650°C)
- 304 stainless steel sheath temperatures to 1200°F (650°C)
- Steel sheath temperatures to 750°F (400°C)
- Copper sheath temperatures to 350°F (175°C)

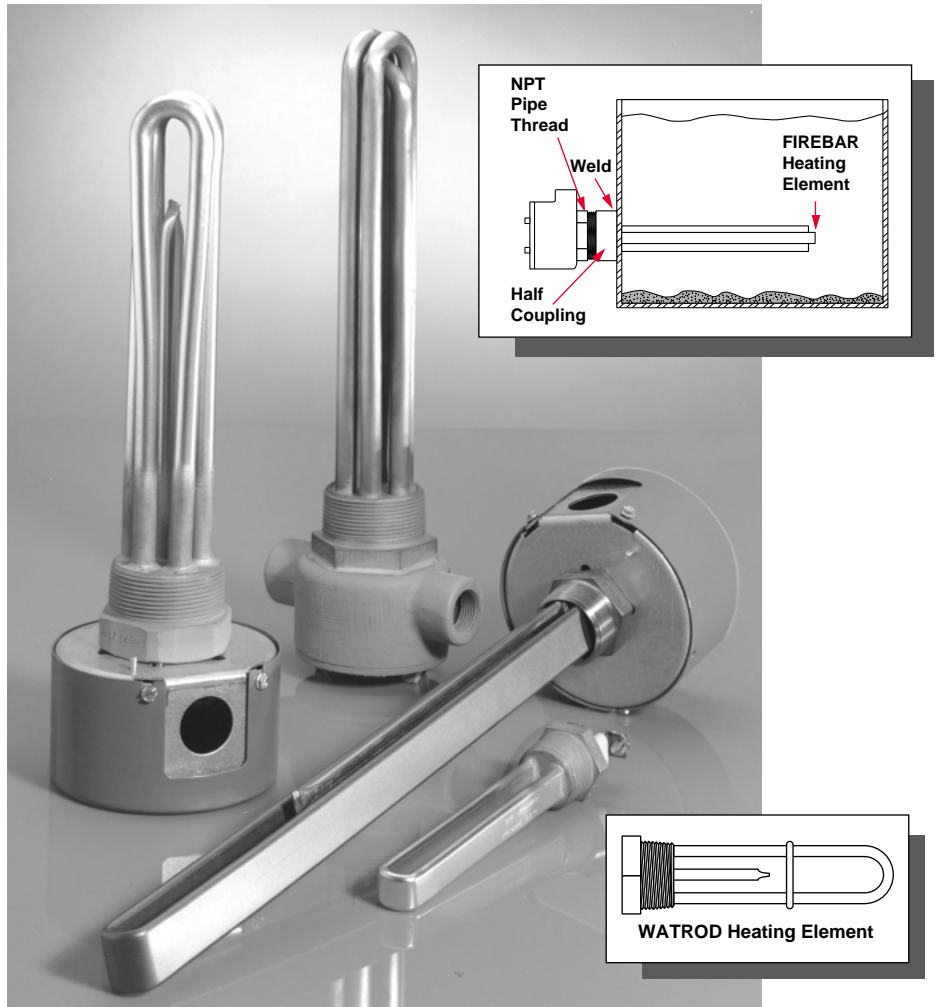

#### Features and Benefits

##### • Screw plug and element sizes:

1" NPT	0.315" WATROD
1¼" NPT	0.315" WATROD 1" FIREBAR
2" NPT	0.475" WATROD
2½" NPT	0.475" WATROD 1" FIREBAR

- **A variety of element sheath and screw plug materials** to meet application needs.
- **Integral thermowells** provide convenient temperature sensor insertion and replacement without draining the fluid being heated.
- **Terminal enclosures** can be rotated to simplify connection with existing conduits.

- **Welding or brazing** WATROD and FIREBAR elements to the screw plug provides a pressure tight seal.
- **WATROD hairpins are repressed (recompacted)** to maintain MgO density, dielectric strength, heat transfer and life.
- **2½" NPT screw plug assemblies feature element support(s)** to help ensure proper spacing for maximizing heater performance and life.
- **Phase capability:**

1" NPT	1-Phase
1¼", 2", 2½" NPT	1- or 3-Phase

- **UL® and CSA component recognition** under file numbers E52951 and 31388 respectively. See **pages 268-271** for details.

Incoloy® is a registered trademark of Special Metals Corporation.

UL® is a registered trademark of Underwriter's Laboratories, Inc.

# Tubular and Process Assemblies

## Screw Plug Immersion Heaters

### Applications

- Water:
  - Deionized
  - Demineralized
  - Clean
  - Potable
  - Process
- Industrial water rinse tanks
- Vapor degreasers
- Hydraulic oil, crude, asphalt
- Lubricating oils at API specified watt densities
- Air and gas flow
- Caustic solutions
- Chemical baths
- Anti-freeze (glycol) solutions
- Paraffin

### Screw Plug Orientation

Correct element/thermowell orientation assures proper process temperature sensing.

Correct horizontal mounting of WATROD and FIREBAR screw plugs is shown to the right. Correct orientation assures optimum performance and maximum heater life. Additional mounting information is provided in the *Installation and Maintenance Instructions*.

### FIREBAR Heating Element

#### 1½" NPT—One Element

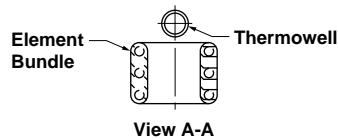
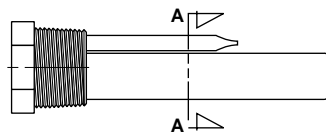

#### 2½" NPT—Three Elements

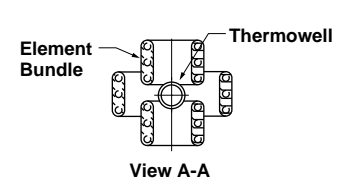
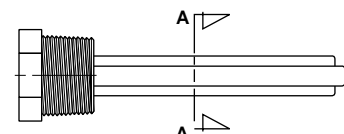

### WATROD Heating Element

#### 1" NPT—One Element

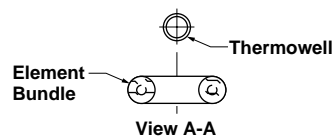
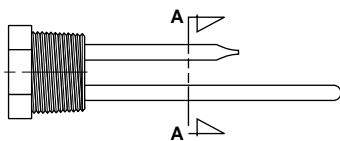

#### 1¼" & 2" NPT—Two Elements

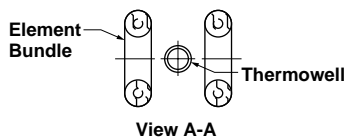
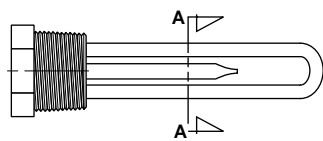

#### 2" & 2½" NPT—Three Elements

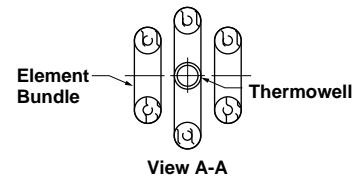
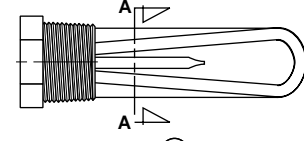

## Options

### Terminal Enclosures

General purpose (NEMA 1) terminal enclosures, without thermostats, are standard on all screw plug immersion heaters. To meet specific application requirements, Watlow offers the following optional terminal enclosures:

- General purpose (NEMA 1) with single or double pole thermostat

- Moisture resistant (NEMA 4) or corrosion resistant (NEMA 4X) — available with optional single or double pole thermostat
- Explosion resistant (NEMA 7) class 1, groups C and D explosion resistant—available with optional single or double pole thermostat. For class 1, group B enclosures, consult your Watlow representative or refer to CSA specifications on [page 271](#).
- Explosion/moisture resistant (NEMA 7/4) combination—

available with optional single or double pole thermostat  
**Note:** Unless otherwise stated on the accompanying illustrations, both WATROD and FIREBAR screw plugs are centered on the terminal enclosure. To order, add the suffix letter(s) to the screw plug heater's base code number. This is depicted on the *Stock and Options* ordering example on [page 336](#). Also, specify class and group, if applicable.

# Tubular and Process Assemblies

## Screw Plug Immersion Heaters

### Options

Continued

#### General Purpose (NEMA 1)

##### Single Pole Thermostat

All screw plug sizes

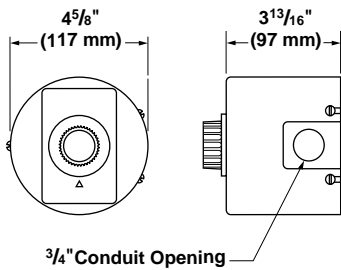

##### Double Pole Thermostat

All screw plug sizes

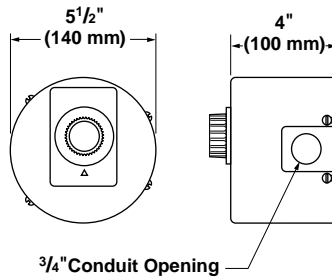

#### Caution:

Explosion-resistant terminal enclosures are intended to provide explosion containment in the electrical termination/wiring enclosure only. No portion of the assembly outside of this enclosure is covered under this NEMA rating. NEMA rating effectiveness may be compromised by abuse or misapplication.

#### Moisture Resistant NEMA 4

##### Without Thermostat

All screw plug sizes

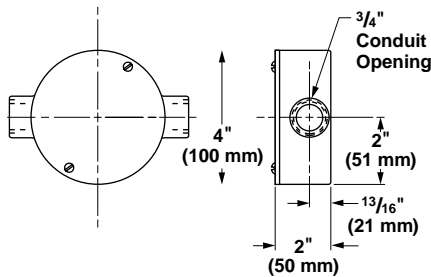

##### Single Pole Thermostat

1" & 1 1/4" NPT-1 WATROD Element

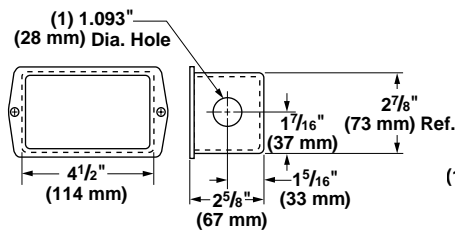

**Note:** The thermostat is not centered on the WATROD screw plug immersion heater.

##### Single or Double Pole Thermostat

1 1/4" NPT-2 WATROD Elements  
1 1/4" NPT-1 FIREBAR Element  
All 2" & 2 1/2" NPT screw plugs

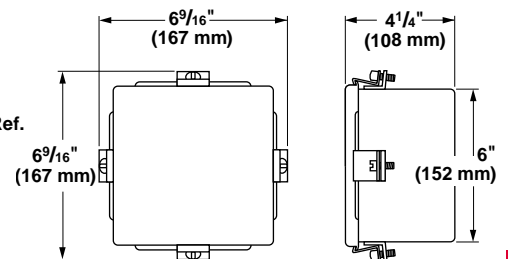

**Note:** The thermostat is not centered on the screw plug immersion heater.

#### Explosion/Moisture Resistant (NEMA 7 or 7/4) ①

##### Without Thermostat

All WATROD screw plugs

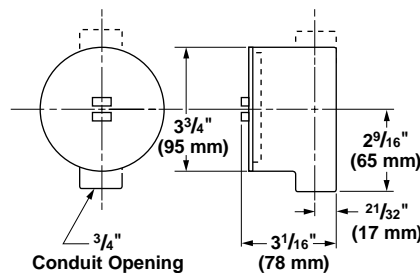

##### Single or Double Pole Thermostat

1 1/4" NPT-1 FIREBAR Element  
All WATROD screw plugs

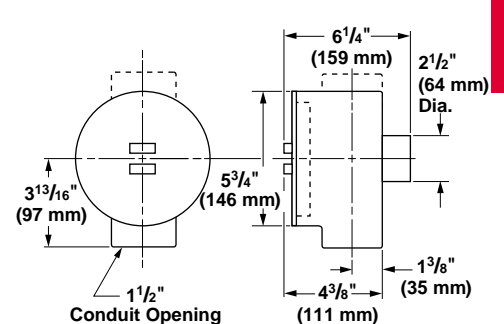

① All NEMA 7/4 rated terminal enclosures supplied with a gasket for the cover.

# Tubular and Process Assemblies

## Screw Plug Immersion Heaters

### Options

Continued

#### Explosion/Moisture Resistant (NEMA 7 or 7/4) ①

##### Without Thermostat

1/4" NPT--1 FIREBAR element

##### Without Thermostat

2 1/2" NPT--3 FIREBAR elements

##### Single or Double Pole Thermostat

2 1/2" NPT--3 FIREBAR elements

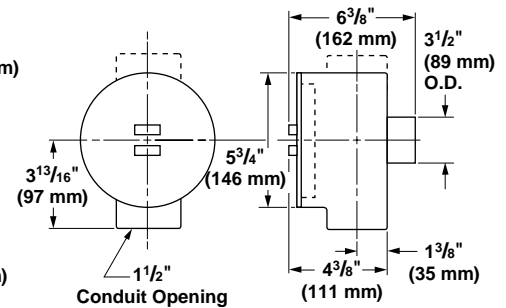
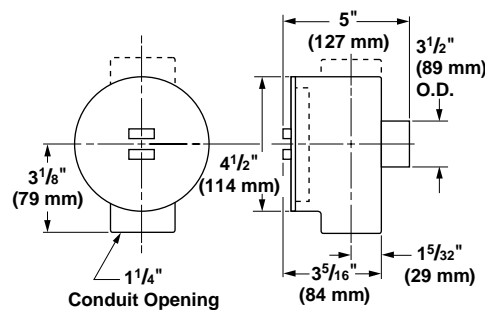
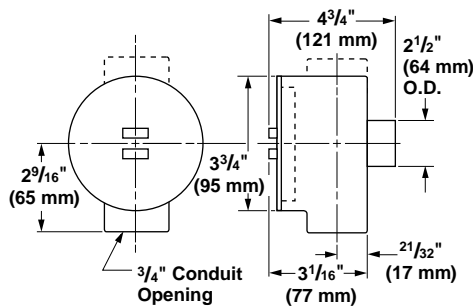

① All NEMA 7/4 rated terminal enclosures supplied with a gasket for the cover.

### CSA Certified Enclosures

CSA certified moisture and/or explosion resistant terminal enclosures protect wiring in hazardous gas environments. These terminal enclosures, covered under

CSA file number 61707, are available on all WATROD and FIREBAR screw plug immersion heaters. For additional information, consult your Watlow representative.

To order, specify **CSA certified enclosure**, **process temperature** (°F), maximum **working pressure** of application (psig), **media** being heated and heater **mounting orientation** (horizontal or vertical) and **screw plug size**.

### Pilot Light

The optional pilot light gives the operator visual indication of heater on or off power status.

The PL10 pilot light is configured to a maximum 250V~(ac), and supplied with six inch (150 mm) leads.

The PL11 pilot light is rated for 480V~(ac), and supplied with four inch (100 mm) leads.

Pilot lights may be attached to either single or double pole thermostats with general purpose (NEMA 1) enclosure only. For moisture or

explosion resistant terminal enclosures (NEMA 4 or NEMA 7), consult factory.

To order, refer to the *Build-a-Code* chart on **page 336**.

### Thermostats

To provide process temperature control, Watlow offers optional single pole, single throw (SPST) and double pole, single throw (DPST) thermostats.

Unless otherwise specified, thermostats are mounted inside the terminal enclosure. For details and ordering information, refer to *Thermostats* on **pages 423 to 425**.

Please verify that the thermostat's sensing bulb O.D. is compatible with the screw plug's thermowell I.D.

## Tubular and Process Assemblies

### Screw Plug Immersion Heaters

#### Options

Continued

#### Thermocouples

Type J or K thermocouples offer extremely accurate sensing of process and/or sheath temperatures. A thermocouple may be inserted into the thermowell or attached to the heater's sheath.

Thermocouples are supplied with 120 inch (305 mm) leads (longer lead lengths available). Unless otherwise specified, thermocouples are supplied with temperature ranges detailed on the *Thermocouple Types* chart.

Using a thermocouple requires an appropriate temperature and power control. These must be purchased

separately. Watlow offers a wide variety of temperature and power controls to meet virtually all applications. Temperature controls can be configured to accept process variable inputs, too. Consult your Watlow representative for details.

To order, specify **Type J** or **K** thermocouple and lead length.

Indicate if the thermocouple is for **process temperature sensing** or heater sheath **high-limit protection**. Please specify if the screw plug will be mounted **vertical** or **horizontal** in the tank. **If vertical, indicate if the housing is on top or bottom.**

If the screw plug heater is mounted in an in-line circulation heating application, indicate flow direction relative to the heater's enclosure.

#### Thermocouple Types

ASTM Type	Conductor Characteristics		Recommended <sup>①</sup> Temperature Range	
	Positive	Negative	°F	(°C)
J	Iron (Magnetic)	Constantan (Non-Magnetic)	0 to 1000	(-20 to 540)
K	Chromel® (non-magnetic)	Alumel® (Magnetic)	0 to 2000	(-20 to 1100)

<sup>①</sup> Type J and Type K thermocouples are rated 32 to 1382°F and 32 to 2282°F (0-750°C and 0-1250°C), respectively. Watlow does not recommend exceeding temperature ranges shown on this chart for the tubular product line.

#### Wattages and Voltages

Watlow routinely supplies screw plug immersion heaters with 120 to 480V~(ac) as well as wattages from

250 watts to 38kW. If required, Watlow will configure heaters with voltages and wattages outside these parameters. For more information on

special voltage and wattage configurations, consult your Watlow representative.

#### Sheath Materials

The following sheath materials are available on WATROD and FIREBAR heating elements:

#### Standard Sheath Materials

WATROD	Incoloy®
	316 stainless steel
	Steel
	Copper
FIREBAR	Incoloy®

#### Made-to-Order Sheath Materials

WATROD	304 stainless steel Monel®
FIREBAR	304 stainless steel

#### Exotic Sheath Materials

Consult your Watlow representative for details and availability.

#### External Finishing

##### Passivation

During the manufacturing process, particles of iron or tool steel may become embedded in the stainless steel or alloy sheath. If not removed, these particles may corrode,

produce rust spots and/or contaminate the process. For critical applications, passivation will remove free iron from the sheath. To order, specify **passivation**.

##### Other Finishes

Simple belt polishing and glass beading are available to meet cosmetic demands. Consult factory for details.

Incoloy® and Chromel® are registered trademarks of the Hoskins Manufacturing Company. Monel® is a registered trademark of Special Metals Corporation.

# Tubular and Process Assemblies

## Screw Plug Immersion Heaters

### Options

Continued

#### Screw Plug Materials

The following screw plug materials are available:

To order, specify **screw plug size** and **material**.

#### Standard Screw Plug Materials

<b>WATROD</b>	304 stainless steel
	316 stainless steel
	Steel
	Brass
<b>FIREBAR</b>	304 stainless steel

#### Made-to-Order Plug Materials

For both WATROD and FIREBAR, consult factory about details and availability.

#### Screw Plug Sizes

Including European

- **NPT**–1, 1¼, 2, 2½ inch
- **Gas**–G1¼, G1½, G 2 inch (brass only)

- **BSP**–1½ inch (stainless steel only)

Consult factory for sizes and materials not listed.

To order, specify **size, style** (NPT, Gas or BSP) and material.

BSP = British Standard Pipe  
Gas = Gas pipe standard

#### Screw Plug to Flange Adaptors

Screw plug to flange adaptors permit replacing flange heaters with screw plug heaters. To order, specify the appropriate code number.

#### Screw Plug to Flange Adaptors

Screw Plug to Flange Adaptor Sizes	Material	Estimated Shipping Wt.		Availability	Code Number
		lbs	(kg)		
1 ¼ to 3"-150#	Steel	13	(5.9)	Stock	<b>125X3SA</b>
2 ½ to 3"-150#	Steel	11	(5.0)	Stock	<b>250X3SA</b>
2 ½ to 4"-150#	Steel	16	(7.3)	Stock	<b>250X4SA</b>
2 ½ to 5"-150#	Steel	25	(11.3)	Stock	<b>250X5SA</b>
2 ½ to 6"-150#	Steel	33	(15.0)	Stock	<b>250X6SA</b>

#### Application Hints

- Select the recommended sheath material and watt density for the substance being heated. Use the **Supplemental Applications Chart** on **pages 263 to 266**. If unable to determine the correct heater material and type, consult your Watlow representative.
- Extend the element's no-heat section completely into the fluid being heated to help prevent premature heater failure. See accompanying illustration for proper no-heat section placement.
- Locate screw plug heater low in the tank, but above the sludge level.

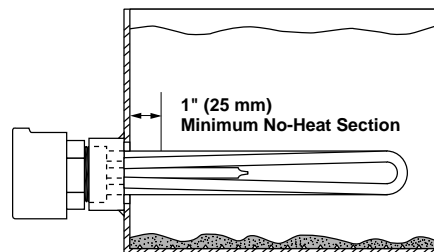

- Choose a FIREBAR element when your application requires a smaller system package or lower watt density.
- Ensure wiring integrity by making sure terminal enclosure temperature does not exceed 400°F (205°C).
- Keep electrical connections clean, dry and tight.

- Minimize problems associated with low liquid level conditions by using a low liquid level sensor or sheath temperature high-limit control.
- Periodically remove the screw plug assembly for inspection and clean the heating element(s). This preventive maintenance will reduce premature failure and optimize heater performance.
- Refer to the *Installation and Maintenance Instructions* for correct orientation of FIREBAR elements. Correct element orientation to flow minimizes pressure drop, increases buoyancy force and heater performance.

# Tubular and Process Assemblies

## Screw Plug Immersion Heaters

### Screw Plug Heater Dimensions

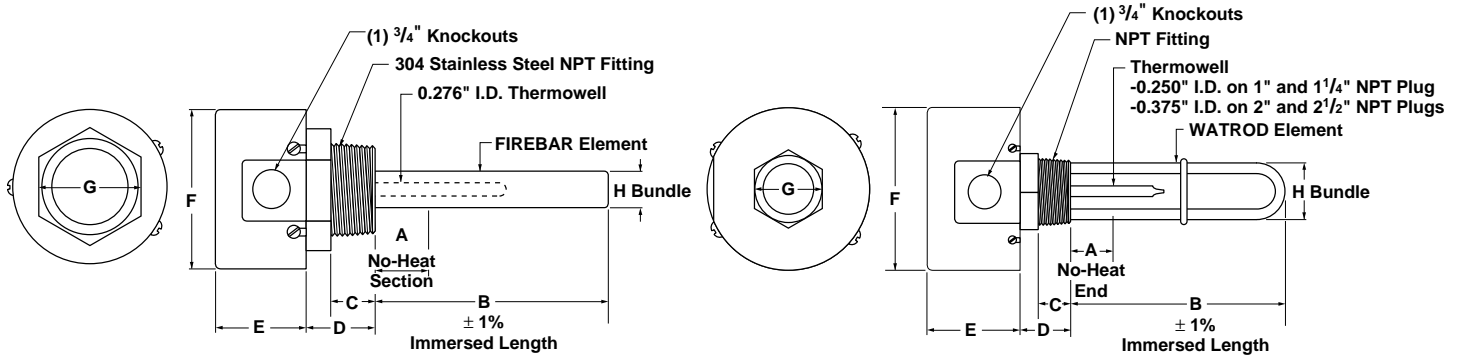

### WATROD and FIREBAR Screw Plug Immersion Heater Dimensions

Heater Type	NPT Size in	A Dimension in (mm)	C Dimension in (mm)	D Dimension in (mm)	E Dimension in (mm)	F Dimension in (mm)	G Dimension in (mm)	H Dimension* in (mm)
WATROD	1	1 (25)	5/8 (22)	1 1/4 (32)	2 5/8 (67)	4 5/8 (117)	1 3/8 (35)	1 1/8 (29)
WATROD	1 1/4	1 15/16 (24)	15/16 (24)	1 5/8 (33)	2 5/8 (67)	4 5/8 (117)	1 3/4 (44)	1 3/8 (35)
WATROD	2 Steel	2 5/8 (65)	1 (25)	1 11/16 (43)	2 5/8 (67)	4 5/8 (117)	2 1/2 (64)	2 1/4 (57)
WATROD	2 Brass	2 11/16 (68)	1 1/8 (27)	1 3/8 (40)	2 5/8 (67)	4 5/8 (117)	2 1/2 (64)	2 1/4 (57)
WATROD	2 S. Steel	2 13/16 (71)	1 (25)	1 5/8 (41)	2 5/8 (67)	4 5/8 (117)	2 1/2 (64)	2 1/4 (49)
WATROD	2 1/2	2 3/8 (56)	1 5/8 (33)	2 1/8 (52)	2 5/8 (67)	4 5/8 (117)	3 1/2 (76)	2 1/2 (64)
FIREBAR	1 1/4	3 7/8 (98)	13/16 (21)	1 1/8 (27)	2 5/8 (67)	4 5/8 (117)	1 3/4 (44)	1 3/8 (35)
FIREBAR	2 1/2	3 3/8 (86)	1 1/4 (32)	1 1/2 (38)	2 5/8 (67)	4 5/8 (117)	3 1/2 (76)	2 1/2 (64)

\* Note: All plug bundles fit into equivalent NPT coupling. They do not fit in equivalent pipe sizes.

### 1" NPT Screw Plug – WATROD Element

WATROD Description	kW	Immersed B Dimension inch (mm)	Code No.		Est. Ship. Weight lbs (kg)
			120V~(ac) 1-Phase	240V~(ac) 1-Phase	

#### Application: Clean Water

60 W/in <sup>2</sup> Brass Plug 1-Copper (9.3 W/cm <sup>2</sup> )	0.5	4 1/2 (114)	BCC4J1	BCC4J10	3 (2)
	0.75	6 1/2 (165)	BCC6J1	BCC6J10	3 (2)
	1.0	6 5/8 (168)	BCC6L1	BCC6L10	3 (2)
	1.25	8 (203)	BCC8A1	BCC8A10	4 (2)
	1.5	10 5/8 (270)	BCC10L1	BCC10L10	4 (2)
	2.0	12 1/2 (318)	BCC12J1	BCC12J10	5 (3)
	2.5	14 3/4 (375)	BCC14N1	BCC14N10	5 (3)
	3.0	16 3/4 (426)	BCC16N1	BCC16N10	6 (3)
	4.0	21 (533)		BCC21A10	6 (3)

#### Applications: Lightweight Oils, Degreasing Solutions, Heat Transfer Oils

23 W/in <sup>2</sup> Steel Plug 1-Steel (3.6 W/cm <sup>2</sup> )	0.25	6 1/2 (165)	BCS6J1	BCS6J10	3 (2)
	0.35	9 1/4 (235)	BCS9E1	BCS9E10	4 (2)
	0.5	9 3/8 (238)	BCS9G1	BCS9G10	4 (2)
	0.75	13 1/2 (343)	BCS13J1	BCS13J10	5 (3)
	1.0	16 3/4 (425)	BCS16N1	BCS16N10	6 (3)
	1.5	23 3/4 (603)	BCS23N1	BCS23N10	7 (4)

All heating elements are Assembly Stock unless otherwise noted.

#### Availability

Assembly Stock: Three to five working days

# Tubular and Process Assemblies

## Screw Plug Immersion Heaters

### 1/4" NPT Screw Plug – WATROD Element

WATROD Description	kW	Immersed B Dimension inch (mm)	Code No.			Est. Ship. Weight lbs (kg)
			120V~(ac) 1-Phase	120/240V~(ac) 1-Phase	240V~(ac) 1-Phase	

#### Application: Clean Water

<b>60 W/in<sup>2</sup></b> <b>Brass Plug</b>	0.5	4 3/8 (111)	<b>BDC4G1</b>		<b>BDC4G10</b>	3 (2)
	0.75	6 3/8 (162)	<b>BDC6G1</b>		<b>BDC6G10</b>	3 (2)
<b>1-Copper</b> (9.3 W/cm <sup>2</sup> )	1.0	4 3/8 (111)		<b>BEC4G6</b>		4 (2)
	1.5	6 3/8 (162)		<b>BEC6G6</b>		4 (2)
	2.0	8 1/2 (216)		<b>BEC8J6</b>		5 (3)
	2.5	10 3/4 (273)		<b>BEC10N6</b>		5 (3)
	3.0	15 (381)		<b>BEC15A6</b>		6 (3)
	4.0	19 (483)			<b>BEC19A10</b>	7 (4)
	5.0	23 1/2 (597)			<b>BEC23J10</b>	8 (4)
	6.0	27 1/2 (699)			<b>BEC27J10</b>	9 (4)

#### Applications: Lightweight Oils, Degreasing Solutions, Heat Transfer Oils

<b>23 W/in<sup>2</sup></b> <b>Steel Plug</b>	0.5	6 3/8 (162)		<b>BES6G6</b>		4 (2)
	0.5	7 3/8 (187)		<b>BES7G6</b>		4 (2)
	0.7	8 3/8 (225)		<b>BES8R6</b>		5 (3)
	0.75	10 1/8 (256)		<b>BES10B6</b>		5 (3)
	1.0	12 3/4 (324)		<b>BES12N6</b>		6 (3)
	1.5	19 3/8 (492)		<b>BES19G6</b>		7 (4)
	2.0	25 3/8 (645)		<b>BES25G6</b>		8 (4)
	3.0	36 3/8 (937)		<b>BES36R6</b>		9 (4)

#### Applications: Forced Air and Gases, Caustic Solutions, Degreasing Solutions

<b>23 W/in<sup>2</sup></b> <b>304 SS Plug</b>	1.0	13 3/8 (340)		<b>BEN13G6</b>		6 (3)
	1.5	19 (483)		<b>BEN19A6</b>		7 (4)
	2.0	24 3/8 (619)		<b>BEN24G6</b>		8 (4)
<b>2-Incoloy®</b> (3.6 W/cm <sup>2</sup> )						

### 1/4" NPT Screw Plug– FIREBAR Element

FIREBAR Description	kW	Immersed B-Dimension inch (mm)	Code No.			Est. Ship. Weight lbs (kg)
			240V~(ac) 1-Phase	240V~(ac) 3-Phase	480V~(ac) 3-Phase	

#### Applications: Clean and Potable Water

<b>90 W/in<sup>2</sup></b> <b>304 SS Plug</b>	1.5	7 3/8 (194)	<b>BDNF7R10</b> ② ⑦		<b>BDNF7R11</b> ② ⑦	5 (3)	
	3.0	11 1/8 (283)	<b>BDNF11G10</b> ② ⑦		<b>BDNF11G11</b> ② ⑦	6 (3)	
	<b>1-Incoloy®</b> (14 W/cm <sup>2</sup> )	5.0	16 3/8 (410)		<b>BDNF16G3</b>	<b>BDNF16G5</b>	7 (4)
		6.5	19 3/8 (486)		<b>BDNF19G3</b>	<b>BDNF19G5</b>	8 (4)
		8.5	24 3/8 (619)		<b>BDNF24L3</b>	<b>BDNF24L5</b>	9 (4)
		10.5	29 3/8 (753)		<b>BDNF29R3</b>	<b>BDNF29R5</b>	10 (5)
	12.7	34 3/8 (879)		<b>BDNF34R3</b>	<b>BDNF34R5</b>	11 (5)	
	17.0	45 3/8 (1146)		<b>BDNF45G3</b>	<b>BDNF45G5</b>	13 (6)	
	21.5	55 3/8 (1413)			<b>BDNF55R5</b>	15 (7)	

All heating elements are Assembly Stock unless otherwise noted.  
**Availability**  
**Assembly Stock:** Three to five working days  
**Standard:** 10 working days

**CONTINUED** 

- ② Standard
- ④ Wired for higher voltage.
- ⑦ Not available as 3-phase – 1-phase only.
- ⑧ Can be wired 1-phase.

## Tubular and Process Assemblies

### Screw Plug Immersion Heaters

#### 1¼" NPT Screw Plug – FIREBAR Element

FIREBAR Description	kW	Immersed B Dimension inch (mm)	Code No.			Est. Ship. Weight lbs (kg)
			240V~(ac) 1-Phase	240V~(ac) 3-Phase	480V~(ac) 3-Phase	

#### Applications: Process Water, Ethylene Glycol (50%)

45 W/in <sup>2</sup> ®	2.0	13 (330)		BDNF13A27		6 (3)
304 SS Plug	2.5	15½ (394)		BDNF15J27		7 (4)
1-Incoloy®	3.0	18 (457)		BDNF18A27		8 (4)
(7 W/cm <sup>2</sup> )	4.0	22½ (572)		BDNF22J27	BDNF22J28	9 (4)
	5.0	27½ (699)		BDNF27J27	BDNF27J28	10 (5)
	6.0	32½ (826)		BDNF32J27	BDNF32J28	11 (5)
	8.0	42 (1067)		BDNF42A27	BDNF42A28	13 (6)
	10.0	51½ (1308)		BDNF51J27	BDNF51J28	15 (7)

#### Applications: Cooking Oils, Ethylene Glycol (100%)

30 W/in <sup>2</sup> ®	1.7	16½ (410)		BDNF16G12	BDNF16G13	7 (4)
304 SS Plug	2.2	19½ (486)		BDNF19G12	BDNF19G13	8 (4)
1-Incoloy®	2.8	24¾ (619)		BDNF24L12	BDNF24L13	9 (4)
(4.7 W/cm <sup>2</sup> )	3.5	29¾ (752)		BDNF29R12	BDNF29R13	10 (5)
	4.25	34¾ (880)		BDNF34R12	BDNF34R13	11 (5)
	5.7	45¾ (1146)		BDNF45G12	BDNF45G13	13 (6)
	7.2	55¾ (1413)		BDNF55R12	BDNF55R13	15 (7)

#### Applications: Heat Transfer Oils, Mineral Oils, Degreasing Solutions

23 W/in <sup>2</sup> ®	1.25	16½ (410)		BDNF16G20		7 (4)
304 SS Plug	1.65	19½ (486)		BDNF19G20		8 (4)
1-Incoloy®	2.15	24¾ (619)		BDNF24L20	BDNF24L19	9 (4)
(3.6 W/cm <sup>2</sup> )	2.65	29¾ (752)		BDNF29R20	BDNF29R19	10 (5)
	3.2	34¾ (879)		BDNF34R20	BDNF34R19	11 (5)
	4.25	45¾ (1146)		BDNF45G20	BDNF45G19	13 (6)
	5.4	55¾ (1413)		BDNF55R20	BDNF55R19	15 (6)

#### Applications: Medium Weight Oils, Heat Transfer Oils, Lubrication Oils, Liquid Paraffin

15 W/in <sup>2</sup> ®	0.67	13 (330)		BDNF13A29		6 (3)
304 SS Plug	0.83	15½ (394)		BDNF15J29		7 (4)
1-Incoloy®	1.0	18 (457)		BDNF18A29		8 (4)
(2.3 W/cm <sup>2</sup> )	1.33	22½ (572)		BDNF22J29	BDNF22J30	9 (4)
	1.67	27½ (699)		BDNF27J29	BDNF27J30	10 (5)
	2.0	32½ (826)		BDNF32J29	BDNF32J30	11 (5)
	2.67	42 (1067)		BDNF42A29	BDNF42A30	13 (6)
	3.33	51½ (1308)		BDNF51J29	BDNF51J30	15 (7)

#### Applications: Bunker C and #6 Fuel Oils, Asphalt

8 W/in <sup>2</sup> ®	0.43	16½ (410)		BDNF16G22		7 (4)
304 SS Plug	0.55	19½ (486)		BDNF19G22		8 (4)
1-Incoloy®	0.7	24¾ (619)		BDNF24L22	BDNF24L21	9 (4)
(1.3 W/cm <sup>2</sup> )	0.88	29¾ (753)		BDNF29R22	BDNF29R21	10 (5)
	1.08	34¾ (880)		BDNF34R22	BDNF34R21	11 (5)
	1.4	45¾ (1146)		BDNF45G22	BDNF45G21	13 (6)
	1.8	55¾ (1413)		BDNF55R22	BDNF55R21	15 (7)

③ Must be operated 3-phase only.

⑧ Can be wired 1-phase.

All heating elements are Assembly Stock unless otherwise noted.

**Availability**  
**Assembly Stock:** Three to five working days

# Tubular and Process Assemblies

## Screw Plug Immersion Heaters

**2" NPT Screw Plug – WATROD Element** (Note: Will not fit into a two inch pipe)

WATROD Description	kW	Immersed B Dimension inch (mm)	Code No.					Est. Ship. Weight lbs (kg)
			120V~(ac) 1-Phase	120/240V~(ac) 1-Phase	240/480V~(ac) 1-Phase	240V~(ac) 3-Phase	480V~(ac) 3-Phase	

### Application: Clean Water

<b>60 W/in<sup>2</sup> ④</b> <b>Brass Plug</b> <b>2-Copper</b> (9.3 W/cm <sup>2</sup> )	2.0	8 1/8 (206)		<b>BGC78C6</b>	<b>BGC78C7</b>			4 (2)
	3.0	11 1/8 (283)		<b>BGC711C6</b>	<b>BGC711C7</b>			5 (3)
	4.0	15 1/8 (384)		<b>BGC715C6</b>	<b>BGC715C7</b>			6 (3)
	5.0	18 1/8 (460)		<b>BGC718C6</b>	<b>BGC718C7</b> ②			6 (3)
	6.0	21 1/8 (537)			<b>BGC721C7</b>			7 (4)
	8.0	26 5/8 (676)			<b>BGC726L7</b>			7 (4)
	10.0	32 1/8 (816)			<b>BGC732C7</b>			8 (4)
<b>60 W/in<sup>2</sup></b> <b>Brass Plug</b> <b>3-Copper</b> (9.3 W/cm <sup>2</sup> )	3.0	8 1/8 (206)	<b>BHC78C1</b>			<b>BHC78C3</b>	<b>BHC78C13</b> ②③	5 (3)
	4.5	11 1/8 (283)	<b>BHC711C1</b>			<b>BHC711C3</b>	<b>BHC711C5</b>	6 (3)
	6.0	15 1/8 (384)				<b>BHC715C3</b>	<b>BHC715C5</b>	7 (4)
	7.5	18 1/8 (460)				<b>BHC718C3</b>	<b>BHC718C5</b>	7 (4)
	9.0	21 1/8 (537)				<b>BHC721C3</b>	<b>BHC721C5</b>	8 (4)
	12.0	26 5/8 (676)				<b>BHC726L3</b>	<b>BHC726L5</b>	8 (4)
	15.0	32 1/8 (816)				<b>BHC732C3</b>	<b>BHC732C5</b>	9 (4)

### Application: Process Water

<b>48 W/in<sup>2</sup> ④</b> <b>304 SS Plug</b> <b>2-Incoloy®</b> (7.5 W/cm <sup>2</sup> )	2.0	9 3/4 (248)		<b>BGN79N6</b>	<b>BGN79N7</b>			4 (2)
	3.0	13 3/4 (337)		<b>BGN713E6</b>	<b>BGN713E7</b>			5 (3)
	4.0	17 3/4 (451)		<b>BGN717N6</b>	<b>BGN717N7</b>			6 (3)
	5.0	20 3/4 (514)		<b>BGN720E6</b>	<b>BGN720E7</b>			7 (4)
	6.0	25 3/4 (641)			<b>BGN725E7</b>			7 (4)
	8.0	32 3/4 (832)			<b>BGN732N7</b>			8 (4)
	10.0	40 3/4 (1022)			<b>BGN740E7</b>			9 (4)
<b>48 W/in<sup>2</sup> ⑤</b> <b>304 SS Plug</b> <b>3-Incoloy®</b> (7.5 W/cm <sup>2</sup> )	3.0	9 3/4 (248)	<b>BHN79N1</b>			<b>BHN79N3</b> ②	<b>BHN79N5</b>	5 (3)
	4.5	13 3/4 (337)	<b>BHN713E1</b>			<b>BHN713E3</b> ②	<b>BHN713E5</b> ②	6 (3)
	6.0	17 3/4 (451)				<b>BHN717N3</b> ②	<b>BHN717N5</b> ②	7 (4)
	7.5	20 3/4 (514)				<b>BHN720E3</b> ②	<b>BHN720E5</b> ②	8 (4)
	9.0	25 3/4 (641)				<b>BHN725E3</b> ②	<b>BHN725E5</b> ②	9 (4)
	12.0	32 3/4 (832)				<b>BHN732N3</b> ②	<b>BHN732N5</b> ②	9 (4)
	15.0	40 3/4 (1022)				<b>BHN740E3</b>	<b>BHN740E5</b> ②	10 (5)
	18.0	47 3/4 (1213)				<b>BHN747N3</b> ②	<b>BHN747N5</b> ②	11 (5)

CONTINUED 

All heating elements are Assembly Stock unless otherwise noted.

#### Availability

**Assembly Stock:** Three to five working days

② Stock

③ Must be operated 3-phase only.

④ Wired for higher voltage.

⑤ 240V~(ac) can be wired wye and operated at 480V~(ac) 3-phase to produce 1/3 more kW

# Tubular and Process Assemblies

## Screw Plug Immersion Heaters

**2" NPT Screw Plug – WATROD Element (Note: Will not fit into a two inch pipe)**

WATROD Description	kW	Immersed B Dimension inch (mm)	Code No.					Est. Ship.
			120V~(ac) 1-Phase	120/240V~(ac) 1-Phase	240/480V~(ac) 1-Phase	240V~(ac) 3-Phase	480V~(ac) 3-Phase	Weight lbs (kg)

**Applications: Forced Air and Gases, Caustic Solutions, Degreasing Solutions**

<b>23 W/in<sup>2</sup> ⑤⑥</b> <b>304 SS Plug</b> <b>3-Incoloy®</b> (3.6 W/cm <sup>2</sup> )	3.0	17 ¼ (451)	<b>BHNA17N1</b>			<b>BHNA17N3</b> ①	<b>BHNA17N5</b> ①	7 (4)
	4.5	25 ¼ (641)						<b>BHNA25E1</b>
	6.0	32 ¼ (832)				<b>BHNA32N3</b>	<b>BHNA32N5</b> ①	
	7.5	40 ¼ (1022)						
	9.0	47 ¼ (1213)				<b>BHNA47N3</b>	<b>BHNA47N5</b>	
	12.5	64 ¼ (1632)						
15.0	76 ¼ (1950)				<b>BHNA76E3</b>	<b>BHNA76E5</b>	18 (9)	

**Applications: Lightweight Oils, Degreasing Solutions, Heat Transfer Oils**

<b>23 W/in<sup>2</sup> ④</b> <b>Steel Plug</b> <b>2-Steel</b> (3.6 W/cm <sup>2</sup> )	1.0	9 ½ (241)		<b>BGS79J6</b>	<b>BGS713J6</b> ①	<b>BGS79J7</b>			4 (2)																			
	1.5	13 ½ (343)							<b>BGS717J6</b> ①	<b>BGS713J7</b> ①	5 (3)																	
	2.0	17 ½ (445)									<b>BGS717J7</b>	6 (3)																
	2.5	20 ½ (521)										<b>BGS720J6</b>	7 (4)															
	3.0	25 (635)											<b>BGS720J7</b>	7 (4)														
	4.0	32 ½ (826)												<b>BGS725A6</b>	8 (4)													
5.0	40 (1016)	<b>BGS732J6</b>	9 (4)																									
6.0	47 ½ (1207)		<b>BGS740A6</b>	10 (5)																								
<b>23 W/in<sup>2</sup></b> <b>Steel Plug</b> <b>3-Steel</b> (3.6 W/cm <sup>2</sup> )	1.5			9 ½ (241)	<b>BHS79J1</b>			<b>BHS79J3</b>	<b>BHS79J13</b> ③	5 (3)																		
	3.0			17 ½ (445)						<b>BHS717J1</b>					<b>BHS717J3</b>	<b>BHS717J5</b> ①	7 (4)											
	4.5			25 (635)									<b>BHS725A1</b>						<b>BHS725A3</b>	<b>BHS725A5</b>	9 (4)							
	6.0			32 ½ (826)																			<b>BHS732J3</b>	<b>BHS732J5</b>	12 (6)			
	7.5	40 (1016)																									<b>BHS740A3</b>	<b>BHS740A5</b>
	9.0	47 ½ (1207)																										
12.5	64 (1626)						<b>BHS764A3</b>	<b>BHS764A5</b>	17 (8)																			

**Applications: Medium Weight Oils, Heat Transfer Oils, Liquid Paraffin**

<b>16 W/in<sup>2</sup> ③</b> <b>304 SS Plug</b> <b>3-Incoloy®</b> (2.5 W/cm <sup>2</sup> )	1.0	9 ¼ (248)				<b>BHN79N12</b>	<b>BHN79N13</b>	5 (3)								
	1.5	13 ¼ (337)						<b>BHN713E12</b>	<b>BHN713E13</b>	6 (3)						
	2.0	17 ¼ (451)								<b>BHN717N12</b>	<b>BHN717N13</b>	7 (4)				
	2.5	20 ¼ (514)										<b>BHN720E12</b>	<b>BHN720E13</b>	8 (4)		
	3.0	25 ¼ (641)												<b>BHN725E12</b>	<b>BHN725E13</b>	9 (4)
	4.0	32 ¼ (832)														<b>BHN732N12</b>
5.0	40 ¼ (1022)	<b>BHN740E12</b>	<b>BHN740E13</b>	10 (5)												
6.0	47 ¼ (1213)			<b>BHN747N12</b>	<b>BHN747N13</b>	11 (5)										
<b>15 W/in<sup>2</sup></b> <b>Steel Plug</b> <b>3-Steel</b> (2.3 W/cm <sup>2</sup> )	1.5					13 ¼ (337)				<b>BHSS13E3</b>	<b>BHSS13E13</b> ③					
	2.0					17 ½ (445)						<b>BHSS17J3</b>	<b>BHSS17J5</b>			
	2.5					20 ½ (521)								<b>BHSS20J3</b>	<b>BHSS20J5</b>	
	3.0					25 (635)										<b>BHSS25A3</b>
	4.0	32 ½ (826)	<b>BHSS32J3</b>			<b>BHSS32J5</b>										
	5.0	40 (1016)		<b>BHSS40A3</b>	<b>BHSS40A5</b>											
6.0	47 ½ (1207)	<b>BHSS47J3</b>					<b>BHSS47J5</b>	13 (6)								
7.5	58 ½ (1486)							<b>BHSS58J3</b>	<b>BHSS58J5</b>	16 (8)						
9.0	69 ¼ (1772)									<b>BHSS69N3</b>	<b>BHSS69N5</b>	20 (9)				

All heating elements are Assembly Stock unless otherwise noted.

**Availability**

**Assembly Stock:** Three to five working days  
**Stock:** Same day shipment

① Stock

③ 3-phase wye only.

④ Wired for higher voltage.

⑤ 240V~(ac) can be wired wye and operated at 480V~(ac) 3-phase to produce ½ more kW and watt density.

⑥ Can be rewired wye to produce ½ of original kW and watt density (3-phase only).

# Tubular and Process Assemblies

## Screw Plug Immersion Heaters

### 2½" NPT Screw Plug – WATROD Element

WATROD Description	kW	Immersed B Dimension inch (mm)	Code No.			Est. Ship. Weight lbs (kg)
			120V~(ac) 1-Phase	240V~(ac) 3-Phase	480V~(ac) 3-Phase	

#### Applications: Deionized Water, Demineralized Water

<b>60 W/in<sup>2</sup></b>	3.0	7% (194)	<b>BLR77L1</b>	<b>BLR77L3</b>	<b>BLR77L5</b>	6 (3)
<b>316 SS Plug</b>	4.5	10% (270)	<b>BLR710L1</b>	<b>BLR710L3</b>	<b>BLR710L5</b>	7 (4)
<b>3-316 SS</b>	6.0	14% (372)		<b>BLR714L3</b>	<b>BLR714L5</b>	9 (4)
<b>Passivated</b>	7.5	17% (448)		<b>BLR717L3</b>	<b>BLR717L5</b>	9 (4)
(9.3 W/cm <sup>2</sup> )	9.0	20% (524)		<b>BLR720L3</b>	<b>BLR720L5</b>	11 (5)
	12.0	26% (664)		<b>BLR726C3</b>	<b>BLR726C5</b>	12 (6)
	15.0	31% (803)		<b>BLR731L3</b>	<b>BLR731L5</b>	14 (7)
	18.0	37% (943)		<b>BLR737C3</b>	<b>BLR737C5</b>	15 (7)

#### Application: Clean Water

<b>60 W/in<sup>2</sup></b>	3.0	7% (194)	<b>BLC77L1</b>	<b>BLC77L3</b>	<b>BLC77L13</b>	6 (3)
<b>Brass Plug</b>	4.5	10% (270)	<b>BLC710L1</b>	<b>BLC710L3</b>	<b>BLC710L5</b>	7 (4)
<b>3-Copper</b>	6.0	14% (371)		<b>BLC714L3</b>	<b>BLC714L5</b>	9 (4)
(9.3 W/cm <sup>2</sup> )	7.5	17% (448)		<b>BLC717L3</b>	<b>BLC717L5</b>	9 (4)
	9.0	20% (524)		<b>BLC720L3</b>	<b>BLC720L5</b> ①	11 (5)
	12.0	26% (664)		<b>BLC726C3</b>	<b>BLC726C5</b> ①	12 (6)
	15.0	31% (803)		<b>BLC731L3</b>	<b>BLC731L5</b>	14 (7)
	18.0	37% (943)		<b>BLC737C3</b>	<b>BLC737C5</b>	15 (7)

#### Application: Process Water

<b>48 W/in<sup>2</sup></b>	3.0	9% (238)	<b>BLN79G1</b>	<b>BLN79G3</b>	<b>BLN79G5</b>	6 (3)
<b>304 SS Plug</b>	4.5	12% (327)	<b>BLN712R1</b>	<b>BLN712R3</b>	<b>BLN712R5</b>	7 (4)
<b>3-Incoloy®</b>	6.0	17% (441)		<b>BLN717G3</b>	<b>BLN717G5</b> ①	9 (4)
(7.5 W/cm <sup>2</sup> )	7.5	19% (505)		<b>BLN719R3</b>	<b>BLN719R5</b>	11 (5)
	9.0	24% (632)		<b>BLN724R3</b>	<b>BLN724R5</b> ①	12 (6)
	12.0	32% (822)		<b>BLN732G3</b>	<b>BLN732G5</b> ①	14 (7)
	15.0	39% (1013)		<b>BLN739R3</b>	<b>BLN739R5</b>	15 (7)
	18.0	47% (1203)		<b>BLN747G3</b>	<b>BLN747G5</b> ①	17 (8)

CONTINUED 

All heating elements are Assembly Stock unless otherwise noted.

① Stock

#### Availability

**Assembly Stock:** Three to five working days

**Stock:** Same day shipment

# Tubular and Process Assemblies

## Screw Plug Immersion Heaters

### 2½" NPT Screw Plug – WATROD Element

WATROD Description	kW	Immersed B Dimension inch (mm)	Code No.			Est. Ship. Weight lbs (kg)
			120V~(ac) 1-Phase	240V~(ac) 3-Phase	480V~(ac) 3-Phase	

#### Applications: Forced Air and Gases, Caustic Solutions, Degreasing Solutions

<b>23 W/in<sup>2</sup></b> ⑤⑥ <b>304 SS Plug</b> <b>3-Incoloy®</b> (3.6 W/cm <sup>2</sup> )	3.0	17¼ (441)	<b>BLNA17G1</b>	<b>BLNA17G3</b>	<b>BLNA17G5</b>	9 (4)
	4.5	24¾ (632)	<b>BLNA24R1</b>	<b>BLNA24R3</b>	<b>BLNA24R5</b>	12 (5)
	6.0	32¾ (822)		<b>BLNA32G3</b>	<b>BLNA32G5</b> ①	14 (7)
	7.5	39¾ (1013)		<b>BLNA39R3</b>	<b>BLNA39R5</b>	15 (7)
	9.0	47¾ (1203)		<b>BLNA47G3</b>	<b>BLNA47G5</b>	17 (8)
	12.5	63¾ (1622)		<b>BLNA63R3</b>	<b>BLNA63R5</b>	20 (9)
	15.0	76¾ (1940)		<b>BLNA76G3</b>	<b>BLNA76G5</b>	23 (11)

#### Applications: Lightweight Oils, Degreasing Solutions, Heat Transfer Oils

<b>23 W/in<sup>2</sup></b> ⑥ <b>Steel Plug</b> <b>3-Steel</b> (3.6 W/cm <sup>2</sup> )	3.0	17¼ (438)	<b>BLS717E1</b>	<b>BLS717E3</b>	<b>BLS717E5</b> ①	9 (4)
	4.5	24¾ (629)	<b>BLS724N1</b>	<b>BLS724N3</b>	<b>BLS724N5</b>	12 (6)
	6.0	32¾ (819)		<b>BLS732E3</b>	<b>BLS732E5</b> ①	14 (7)
	7.5	39¾ (1010)		<b>BLS739N3</b>	<b>BLS739N5</b>	15 (7)
	9.0	47¾ (1200)		<b>BLS747E3</b>	<b>BLS747E5</b>	17 (8)
	12.5	63¾ (1619)		<b>BLS763N3</b>	<b>BLS763N5</b>	20 (9)
	15.0	76¾ (1937)		<b>BLS776E3</b>	<b>BLS776E5</b>	27 (13)

#### Applications: Medium Weight Oils, Heat Transfer Oils, Liquid Paraffin

<b>16 W/in<sup>2</sup></b> ③ <b>304 SS Plug</b> <b>3-Incoloy®</b> (2.5 W/cm <sup>2</sup> )	1.0	9¾ (238)		<b>BLN79G12</b>	<b>BLN79G13</b>	6 (3)
	1.5	12¾ (327)		<b>BLN712R12</b>	<b>BLN712R13</b>	7 (4)
	2.0	17¾ (441)		<b>BLN717G12</b>	<b>BLN717G13</b>	9 (4)
	2.5	19¾ (505)		<b>BLN719R12</b>	<b>BLN719R13</b>	11 (5)
	3.0	24¾ (632)		<b>BLN724R12</b>	<b>BLN724R13</b>	12 (6)
	4.0	32¾ (822)		<b>BLN732G12</b>	<b>BLN732G13</b>	14 (7)
	5.0	39¾ (1013)		<b>BLN739R12</b>	<b>BLN739R13</b>	15 (7)
	6.0	47¾ (1203)		<b>BLN747G12</b>	<b>BLN747G13</b>	17 (8)

#### Applications: Bunker C and #6 Fuel Oils

<b>8 W/in<sup>2</sup></b> ③ <b>Steel Plug</b> <b>3-Steel</b> (1.3 W/cm <sup>2</sup> )	1.0	17¼ (438)		<b>BLS717E12</b>	<b>BLS717E13</b>	9 (4)
	1.5	24¾ (629)		<b>BLS724N12</b>	<b>BLS724N13</b>	12 (6)
	2.0	32¾ (819)		<b>BLS732E12</b>	<b>BLS732E13</b>	14 (7)
	2.5	39¾ (1010)		<b>BLS739N12</b>	<b>BLS739N13</b>	15 (7)
	3.0	47¾ (1200)		<b>BLS747E12</b>	<b>BLS747E13</b>	17 (8)
	4.0	63¾ (1619)		<b>BLS763N12</b>	<b>BLS763N13</b>	20 (9)
	5.0	76¾ (1937)		<b>BLS776E12</b>	<b>BLS776E13</b>	23 (11)

All heating elements are Assembly Stock unless otherwise noted.

**Availability**

**Assembly Stock:** Three to five working days

**Stock:** Same day shipment

① Stock

③ Must be operated 3-phase only.

⑤ 240V~(ac) can be wired wye and operated at 480V~(ac) 3-phase to produce ½ more kW and watt density.

⑥ Can be rewired wye to produce ½ of original kW and watt density (3-phase only).

# Tubular and Process Assemblies

## Screw Plug Immersion Heaters

### 2½" NPT Screw Plug – FIREBAR Element

FIREBAR Description	kW	Immersed B Dimension inch (mm)	Code No.		Est. Ship. Weight lbs (kg)
			240V~(ac) 3-Phase	480V~(ac) 3-Phase	

#### Applications: Clean and Potable Water

90 W/in <sup>2</sup> ®	15	15 ½ (384)	BLNF15C3	BLNF15C5	10 (5)
304 SS Plug	20	18 ½ (460)	BLNF18C3	BLNF18C5 ③	12 (6)
3-Incoloy®	25	23 ½ (587)		BLNF23C5	14 (7)
(14 W/cm <sup>2</sup> )	32	28 ½ (727)		BLNF28L5	17 (8)
	38	33 ½ (854)		BLNF33L5	18 (9)

#### Applications: Process Water, Ethylene Glycol (50%)

45 W/in <sup>2</sup> ®	6	12 (305)	BLNF12A27		10 (5)
304 SS Plug	7.5	14 ½ (368)	BLNF14J27		11 (5)
3-Incoloy®	9	17 (432)	BLNF17A27		12 (6)
(7 W/cm <sup>2</sup> )	12	21 ½ (546)	BLNF21J27	BLNF21J28	14 (7)
	15	26 ½ (673)	BLNF26J27	BLNF26J28	17 (8)
	18	31 ½ (800)	BLNF31J27	BLNF31J28	18 (9)
	24	41 (1041)		BLNF41A28	20 (9)
	30	50 ½ (1283)		BLNF50J28	22 (10)

#### Applications: Cooking Oils, Ethylene Glycol (100%)

30 W/in <sup>2</sup> ®	5	15 ½ (384)	BLNF15C12	BLNF15C13	10 (5)
304 SS Plug	6.5	18 ½ (460)	BLNF18C12	BLNF18C13	12 (6)
3-Incoloy®	8.5	23 ½ (587)	BLNF23C12	BLNF23C13	14 (7)
(4.7 W/cm <sup>2</sup> )	10.5	28 ½ (727)	BLNF28L12	BLNF28L13	17 (8)
	12.8	33 ½ (854)	BLNF33L12	BLNF33L13	18 (9)
	17	44 ½ (1121)	BLNF44C12	BLNF44C13	20 (9)
	21.5	54 ½ (1388)		BLNF54L13	22 (10)

#### Applications: Heat Transfer Oils, Mineral Oils, Degreasing Solutions

23 W/in <sup>2</sup> ®	3.8	15 ½ (384)	BLNF15C20		10 (5)
304 SS Plug	4.9	18 ½ (460)	BLNF18C20		12 (6)
3-Incoloy®	6.4	23 ½ (587)	BLNF23C20	BLNF23C19	14 (7)
(3.6 W/cm <sup>2</sup> )	7.9	28 ½ (727)	BLNF28L20	BLNF28L19	17 (8)
	9.6	33 ½ (854)	BLNF33L20	BLNF33L19	18 (9)
	12.8	44 ½ (1121)	BLNF44C20	BLNF44C19	20 (9)
	16.1	54 ½ (1387)	BLNF54L20	BLNF54L19	22 (10)

CONTINUED 

All heating elements are Assembly Stock unless otherwise noted.

③ Must be operated 3-phase only.

⑧ Can be wired 1-phase.

#### Availability

**Assembly Stock:** Three to five working days

**Stock:** Same day shipment

## Tubular and Process Assemblies

### Screw Plug Immersion Heaters

#### 2½" NPT Screw Plug – FIREBAR Element

FIREBAR Description	kW	Immersed B Dimension inch (mm)	Code No.		Est. Ship. Weight lbs (kg)
			240V~(ac) 3-Phase	480V~(ac) 3-Phase	

**Applications: Medium Weight Oils, Heat Transfer Oils, Lubrication Oils, Liquid Paraffin**

15 W/in <sup>2</sup> ③	2	12 (305)	BLNF12A29		10 (5)
304 SS Plug	2.5	14 ½ (368)	BLNF14J29		11 (5)
3-Incoloy®	3	17 (432)	BLNF17A29		12 (6)
(2.3 W/cm <sup>2</sup> )	4	21 ½ (546)	BLNF21J29	BLNF21J30	14 (7)
	5	26 ½ (673)	BLNF26J29	BLNF26J30	17 (8)
	6	31 ½ (800)	BLNF31J29	BLNF31J30	18 (9)
	8	41 (1041)	BLNF41A29	BLNF41A30	20 (9)
	10	50 ½ (1283)	BLNF50J29	BLNF50J30	22 (10)

**Applications: Bunker C and #6 Fuel Oils, Asphalt**

8 W/in <sup>2</sup> ③	1.25	15 ½ (384)	BLNF15C22		10 (5)
304 SS Plug	1.63	18 ½ (460)	BLNF18C22		12 (6)
3-Incoloy®	2.13	23 ½ (587)	BLNF23C22	BLNF23C21	14 (7)
(1.3 W/cm <sup>2</sup> )	2.63	28 ½ (727)	BLNF28L22	BLNF28L21	17 (8)
	3.19	33 ½ (854)	BLNF33L22	BLNF33L21	18 (9)
	4.25	44 ½ (1121)	BLNF44C22	BLNF44C21	20 (9)
	5.38	54 ½ (1388)	BLNF54L22	BLNF54L21	22 (10)

All heating elements are Assembly Stock unless otherwise noted.

③ Must be operated 3-phase only.

**Availability**

**Assembly Stock:** Three to five working days

**Stock:** Same day shipment

# Tubular and Process Assemblies

F.O.B.: Hannibal, Missouri

## Screw Plug Immersion Heaters

### Build-a-Code

**Stock Screw Plug Code Number** ① \_\_\_\_\_

(Includes general purpose terminal enclosure (NEMA 1))

**Optional Terminal Enclosure** \_\_\_\_\_

S = General purpose with thermostat (NEMA 1)

W = Moisture resistant (NEMA 4)

E = Explosion resistant (NEMA 7)

E/W = Explosion/moisture resistant (NEMA 7/4)

**Optional Thermostat** ② **or Thermocouple** ④ \_\_\_\_\_

**Optional Pilot Light** ③ \_\_\_\_\_

PL10 = 250V~(ac) Max.

PL11 = 480V~(ac) Max.

- ① Screw plug immersion heaters are supplied with a general purpose terminal enclosure (NEMA 1). A thermostat will not fit inside the standard 2<sup>5</sup>/<sub>8</sub> inch (67 mm) tall general purpose terminal enclosure. If a thermostat is required, a taller terminal enclosure will be supplied.
- ② Thermostat code numbers are shown in the *Thermostat Stock* chart on **page 425**.
- ③ Pilot lights are configured for general purpose enclosure (NEMA 1) applications. For pilot light availability with other terminal enclosure ratings, consult factory.
- ④ Specify Type J or K thermocouple. If overtemp thermocouple specify orientation horizontal, vertical up or vertical down.

### How to Order

To order a stock screw plug heater, please specify:

- Watlow code number
- NPT screw plug size and material
- Volts/watts
- Phase
- Options
- Quantity

If our stock units do not meet your application needs, Watlow can provide made-to-order heaters. For a **made-to-order** unit, please specify:

- Application, including heated material, process temperature and flow rate, etc.
- Volts/watts
- Watt density
- Phase
- Screw plug size, style and material
- Element diameter
- Number of heating element(s)
- Sheath material
- Immersed ('B' dimension) length
- No-heat section below the plug
- Terminal enclosure type
- Options
- Quantity

### Availability

**Stock:** Same day shipment

**Assembly Stock:** Three to five working days

**Modified Stock** ④: Five to seven working days

**Standard:** 10 working days

**Made-to-Order:** Four to six weeks

Options, complexity and quantity may affect availability and lead times. Consult factory.

④ Stock and assembly stock units with catalog options.

## Tubular and Process Assemblies

### Quick Ship

On stock chart units:

- Five working days on all heaters
- 10 working days on special voltages and/or wattages
- 15 working days on special element lengths

### Screw Plug Immersion Heaters with Control Assembly

Constructed from a WATROD screw plug heater, a moisture resistant (NEMA 4) terminal enclosure and built-in temperature sensor and power control, this assembly comes pre-wired and ready for hook-up to any 120V~(ac) control circuit.

Optional sheath materials, NPT screw plug sizes and materials, wattages, voltages and terminal enclosures extend application versatility.

#### Performance Capabilities

- Watt densities to 60 W/in<sup>2</sup> (9.3 W/cm<sup>2</sup>)
- Wattages to 20kW
- Voltages to 600V~(ac)
- Incoloy® sheath temperatures to 1400°F (760°C)

#### Features and Benefits

- **Three 0.475 inch (12 mm) diameter WATROD elements** are brazed to a two inch NPT brass screw plug to produce a pressure-tight seal.
- **WATROD hairpins are repressed (recompacted)** after bending to maintain MgO density, dielectric strength, heat transfer and life.
- **Two built-in thermostats**, one on-off with manual reset, help ensure safe operation by automatically cycling on and off when process or sheath temperatures reach a predetermined set point selectable from 30° to 250°F (0° to 120°C).
- **Internal mechanical contactor** works on a 120V~(ac) control circuit to switch higher volts/amps to the heating elements.

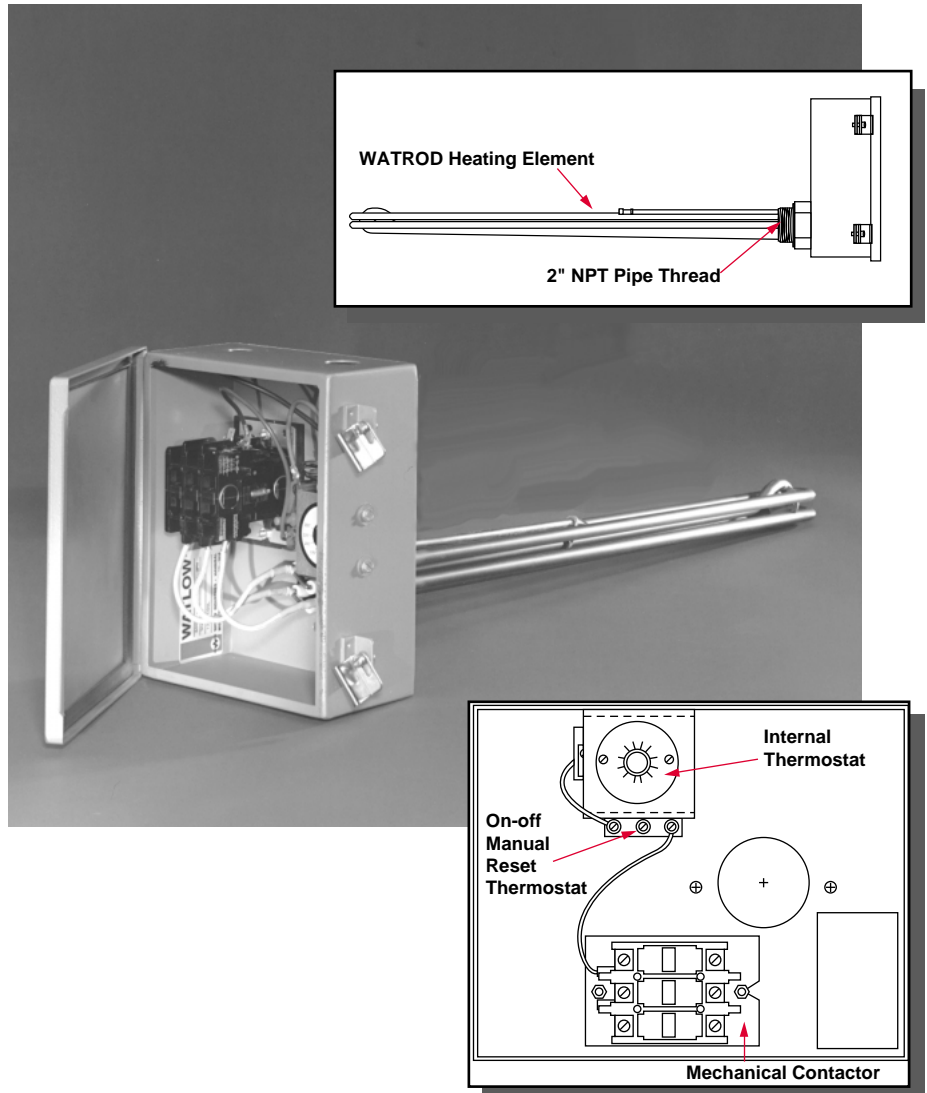

- **Hinged, moisture resistant (NEMA 4) terminal enclosure** has two conduit openings to accommodate ¾ inch NPT conduit fittings.
- **Terminal enclosures can be rotated** to mate with existing conduits.
- **Thermowells** allow replacing the thermostat sensing element without draining the fluid being heated.

#### Applications

- Water heating
- Commercial dishwashers and glass washers
- Sterilizing equipment

#### Construction Features

Same as **Screw Plug Immersion Heaters**. See **pages 321 to 322** for details.

#### Application Hints

Same as **Screw Plug Immersion Heaters**. See **page 326** for details.

#### Accessories

*Clamping Nut, Gasket and Washers*—for mounting to thin-wall tanks, use optional clamping nut, gasket and washers. To order, specify **NGW**.

# Tubular and Process Assemblies

## Screw Plug Immersion Heaters with Control Assembly

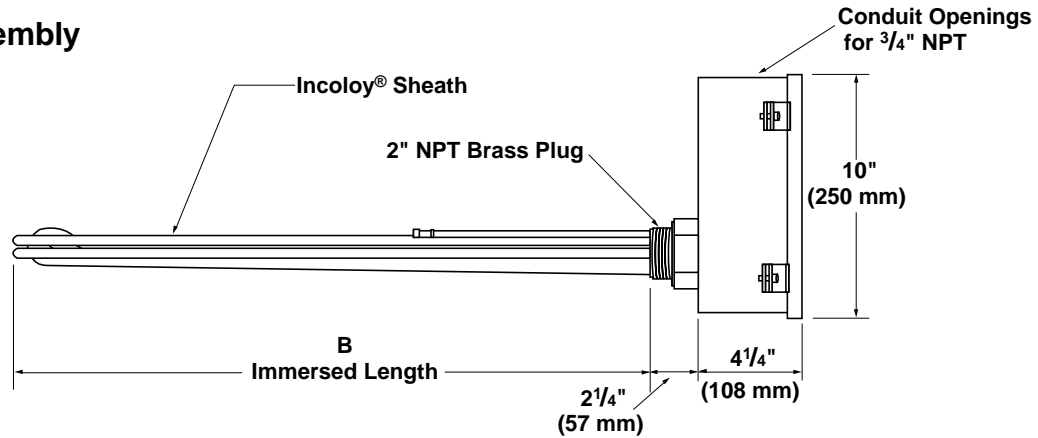

### 2" NPT Brass Screw Plug With Control Box (Assembly Stock)

WATROD Descript.	kW	Immersed Length Inch (mm)	Code Number					Est. Net Weight lbs (kg)
			208V~(ac) 3-Phase	240V~(ac) 3-Phase	380V~(ac) 3-Phase	480V~(ac) 3-Phase	575V~(ac) 3-Phase	
50 W/in <sup>2</sup>	9	24 3/4 (629)		BHNB24N3W2C11		BHNB24N5W2C11	BHNB24N16W2C11	23 (10)
Brass Plug	12	30 (762)	BHNB30A2W2C11	BHNB30A3W2C11	BHNB30A8W2C11	BHNB30A5W2C11	BHNB30A16W2C11	24 (11)
3-Incoloy®	16	35 3/4 (905)	BHNB35L2W2C11	BHNB35L3W2C11	BHNB35L8W2C11	BHNB35L5W2C11	BHNB35L16W2C11	25 (11)
(7.8 W/cm <sup>2</sup> )	20	45 3/4 (1159)		BHNB45L3W2C11	BHNB45L8W2C11	BHNB45L5W2C11	BHNB45L16W2C11	27 (12)

#### How to Order

To order an Assembly Stock unit, please specify:

- Watlow code number
- Volts/watts
- Options, if applicable
- Quantity

If our assembly stock units do not meet your application needs, Watlow can provide **made-to-order** assemblies. For made-to-order units, please specify:

- Volts/watts
- Phase
- Screw plug size and materials
- Number of elements
- Sheath material
- Immersed ('B' dimension) length
- No-heat section below the plug
- Options
- Quantity

#### Availability

**Assembly Stock:** Five working days

**Modified Stock** <sup>Ⓛ</sup>: Five to seven working days

**Made-to-Order:** Four to six weeks

Options, complexity and quantity may affect availability and lead times. Consult factory.

#### Replacement Heater Only

To order a replacement screw plug heater, simply delete the last five characters from the original *Screw Plug Immersion with Control Assembly* base code number.

<sup>Ⓛ</sup> Assembly Stock units with catalog options.

## Tubular and Process Assemblies

### Quick Ship

On stock chart units:

- Three to five working days on most heaters
- 10 working days on special voltages and/or wattages
- 15 working days on special element lengths

## Flange Immersion Heaters

Watlow flange heaters are easy to install and maintain. Designed for heating liquids and gases in tanks and pressure vessels, flange immersion heaters are ideal for applications requiring higher kilowatts.

Watlow flange heaters are made with WATROD or FIREBAR® tubular elements brazed or welded to a flange. Stock flange heaters are equipped with a general purpose (NEMA 1) terminal enclosure.

Flange heaters, with FIREBAR elements, also answer the need for liquid immersion applications requiring high kilowatts in small tanks. The FIREBAR element's unique flat surface geometry packs more power in a smaller bundle, with lower watt density, making it especially well suited for petroleum-based liquid heating applications.

### Performance Capabilities

- Watt densities to 100 W/in<sup>2</sup> (15.5 W/cm<sup>2</sup>)
- Wattages to one megawatt
- UL® and CSA component recognition to 480V~(ac) and 600V~(ac) respectively
- Incoloy® sheath temperatures to 1600°F (870°C)
- Passivated 316 stainless steel sheath temperatures to 1200°F (650°C)
- 304 stainless steel sheath temperatures to 1200°F (650°C)
- Steel sheath temperatures to 750°F (400°C)
- Copper sheath temperatures to 350°F (175°C)

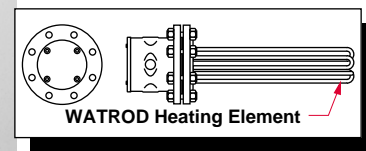
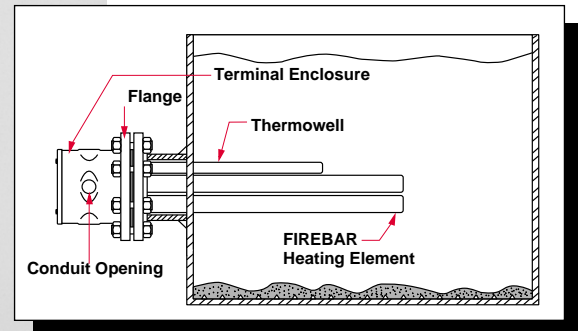
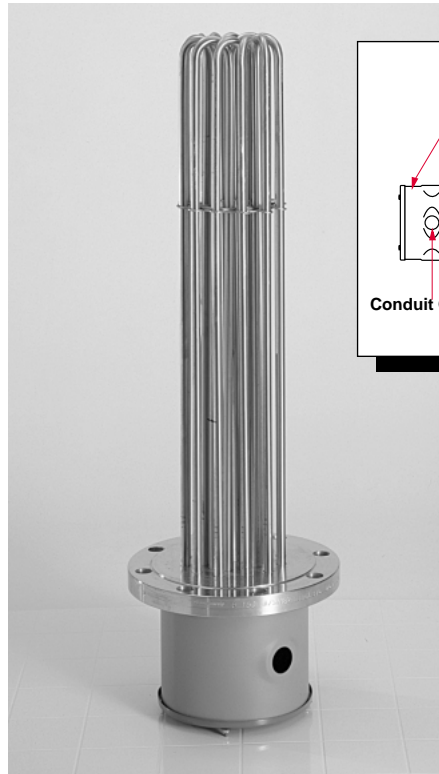

### Features and Benefits

- **ANSI and ANSI compatible 2, 2½, 3, 4, 5, 6, 8, 10, 12 and 14 inch flanges** provide appropriate heater size-to-application and fit.
- **Flange sizes up to 24 inches** available on made-to-order units.
- **Element sheath and flange materials** to meet application needs.
- **Integral thermowells** provide convenient temperature sensor insertion and replacement without draining the fluid being heated.
- **A standard, general purpose (NEMA 1) terminal enclosure** offers easy access to wiring.
- **Element support(s)** provide proper element spacing to maximizing heater performance and life.
- **To facilitate lifting**, drilled and tapped holes come supplied for eye bolts on 10 inch and larger flange heaters.
- **All units are inspected and/or tested** to ensure element-to-flange pressure seals do not leak.
- **Four or six inch FIREBAR flange heaters** pack more kilowatts in smaller bundles—in liquid immersion applications, a conventional 10 inch round tubular element flange can be replaced with a six inch FIREBAR flange.
- **WATROD hairpins are repressed (recompacted)** to maintain MgO density, dielectric strength, heat transfer and life.
- **Branch circuits meet NEC** with 48 amps per circuit maximum.
- **UL® and CSA component recognition** under file numbers E52951 and 31388 respectively. See [pages 268-271](#) for details.

Incoloy® is a registered trademark of Special Metals Corporation.

UL® is a registered trademark of Underwriter's Laboratories.

# Tubular and Process Assemblies

## Flange Immersion Heaters

### Applications

- Water:
  - Deionized
  - Demineralized
  - Clean
  - Potable
  - Process
- Industrial water rinse tanks
- Vapor degreasers
- Hydraulic oil, crude, asphalt
- Lubricating oils at API specified watt densities
- Air and gas flow
- Caustic solutions
- Chemical baths
- Process air equipment
- Boiler equipment
- Freeze protection of any fluid
- Anti-freeze (glycol) solutions
- Paraffin

### Options

#### Terminal Enclosures

General purpose terminal enclosures, without thermostats, are standard on all flange immersion heaters. Optional terminal enclosures include:

- General purpose (NEMA 1) with a single or double pole thermostat.
- Moisture resistant (NEMA 4–steel). Available with or without a single or double pole thermostat.
- Corrosion resistant (NEMA 4X). Available with or without a single or double pole thermostat.
- Explosion resistant (NEMA 7) class 1 groups C and D. Available with or without a single or double pole thermostat.

- Explosion/moisture resistant (NEMA 7/4) combinations. Available with or without a single or double pole thermostat.
- For class 1, group B enclosures, consult your Watlow representative.

#### Enclosure Enhancements

- Enclosure heater to solve condensation and freeze problems.
- Power distribution blocks to facilitate power feed line wiring.

Prior to ordering, refer to the terminal enclosure dimensions on [page 341](#). Order by adding the appropriate suffix letter(s) to the base flange heater code number, as

shown on the Build-a-Code chart. Heater code numbers and suffix letters are depicted on the *Stock* and *Options* charts, [pages 345 to 362](#). Specify class and group, if applicable.



#### Caution

Explosion-resistant terminal enclosures are intended to provide explosion containment in the electrical termination/wiring enclosure only. No portion of the assembly outside of this enclosure is covered under this NEMA rating. NEMA rating effectiveness may be compromised by abuse or misapplication.

#### Stand-off Terminal Enclosures

Stand-off terminal enclosures provide an air-insulating barrier between the flange and terminal enclosure by mounting the terminations and wiring away from the flange. Stand-off terminal enclosures are recommended

whenever a process operating temperature exceeds 400°F (205°C). This helps minimize terminal enclosure temperatures.

To order, specify **stand-off terminal enclosure**.

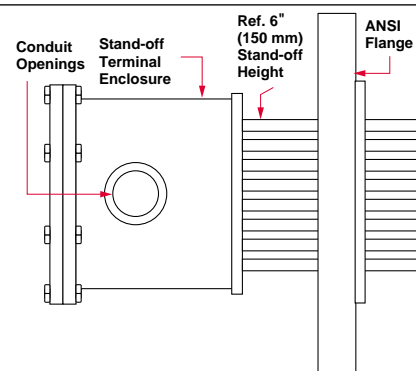

#### CSA Certified Enclosures

CSA certified moisture and/or explosion resistant terminal enclosures protect wiring in hazardous gas environments. These terminal enclosures, covered under CSA file number 61707, are

available on all WATROD and FIREBAR flange heaters. For additional information, consult your Watlow representative.

To order, specify **CSA certified enclosure, process temperature**

(°F), maximum **working pressure** of application (psig), **media** being heated and heater **mounting orientation** (horizontal or vertical) and **flange size**.

# Tubular and Process Assemblies

## Flange Immersion Heaters Options

4-8 inches NEMA 1 and NEMA 4

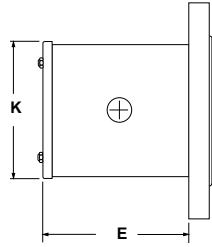

10-14 inches NEMA 1

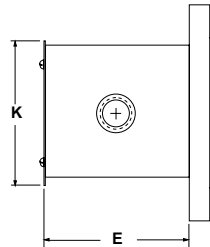

10-14 inches NEMA 4

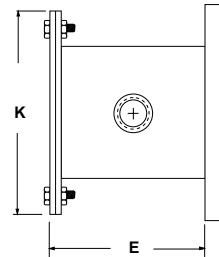

4-14 inches NEMA 7

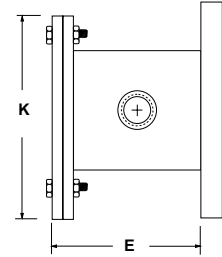

### Terminal Enclosure Dimensions

Enclosure Type	Flange Size inch	Without Thermostat				With Thermostat							
		E Dimension		K Dimension		Single Pole				Double Pole			
		inch	(mm)	inch	(mm)	inch	(mm)	inch	(mm)	inch	(mm)	inch	(mm)
General Purpose (NEMA 1)	2 <sup>①</sup>	1 1/2	(38)	3 3/8	(86)	—	—	—	—	—	—	—	—
	2 1/2 <sup>①</sup>	2 1/8	(54)	4	(102)	—	—	—	—	—	—	—	—
	3	3 13/16	(97)	4 5/8	(117)	9 3/8	(238)	7	(178)	9 3/8	(238)	7	(178)
	4	9 3/8	(238)	7	(178)	9 3/8	(238)	7	(178)	9 3/8	(238)	7	(178)
	5	7 1/16	(179)	7	(178)	7 1/16	(179)	7	(178)	7 1/16	(179)	7	(178)
	6	7 1/16	(179)	8	(203)	7 1/16	(179)	8	(203)	7 1/16	(179)	8	(203)
	8	7 1/16	(179)	10 1/2	(255)	7 1/16	(179)	10 1/2	(255)	7 1/16	(179)	10 1/2	(255)
	10	7 1/16	(179)	11 5/8	(295)	7 1/16	(179)	11 5/8	(295)	7 1/16	(179)	11 5/8	(295)
	12	7 1/16	(179)	13 1/2	(343)	7 1/16	(179)	13 1/2	(343)	7 1/16	(179)	13 1/2	(343)
	14	7 1/16	(179)	15 1/8	(384)	7 1/16	(179)	15 1/8	(384)	7 1/16	(179)	15 1/8	(384)
Moisture Resistant (NEMA 4)	2	2 5/8	(67)	3 1/2	(89)	—	—	—	—	—	—	—	—
	2 1/2	2 5/8	(67)	3 1/2	(89)	—	—	—	—	—	—	—	—
	3	2 1/8	(54)	4	(102)	9 3/8	(238)	7	(178)	9 3/8	(238)	7	(178)
	4	9 3/8	(238)	7	(178)	9 3/8	(238)	7	(178)	9 3/8	(238)	7	(178)
	5	7 1/16	(179)	7	(178)	7 1/16	(179)	7	(178)	7 1/16	(179)	7	(178)
	6	7 1/16	(179)	8	(203)	7 1/16	(179)	8	(203)	7 1/16	(179)	8	(203)
	8	7 1/16	(179)	10 1/2	(255)	7 1/16	(179)	10 1/2	(255)	7 1/16	(179)	10 1/2	(255)
	10	7 3/4	(197)	13 3/4	(349)	7 3/4	(197)	13 3/4	(349)	7 3/4	(197)	13 3/4	(349)
Explosion Resistant (NEMA 7) Class 1, Groups C and D Consult Factory for Group B)	2	3 1/16	(78)	3 3/4	(95)	—	—	—	—	—	—	—	—
	2 1/2	3 1/16	(78)	3 3/4	(95)	—	—	—	—	—	—	—	—
	3	7 1/8	(181)	5 3/4	(146)	7 1/8	(181)	5 3/4	(146)	7 1/8	(181)	5 3/4	(146)
	4	7 1/8	(181)	5 3/4	(146)	7 1/8	(181)	5 3/4	(146)	7 1/8	(181)	5 3/4	(146)
	5	7 1/8	(200)	8 7/8	(225)	7 1/8	(200)	8 7/8	(225)	7 1/8	(200)	8 7/8	(225)
	6	7 1/8	(200)	9 7/8	(251)	7 1/8	(200)	9 7/8	(251)	7 1/8	(200)	9 7/8	(251)
	8	7 1/8	(200)	12 1/8	(308)	7 1/8	(200)	12 1/8	(308)	7 1/8	(200)	12 1/8	(308)
	10	7 1/8	(200)	14 3/8	(371)	7 1/8	(200)	14 3/8	(371)	7 1/8	(200)	14 3/8	(371)
12	7 1/8	(200)	15 1/8	(403)	7 1/8	(200)	15 1/8	(403)	7 1/8	(200)	15 1/8	(403)	
	14	7 1/8	(200)	19 3/8	(492)	7 1/8	(200)	19 3/8	(492)	7 1/8	(200)	19 3/8	(492)

① Terminal enclosure is octagonal, not round.

# Tubular and Process Assemblies

## Flange Immersion Heaters Options

### Thermocouples

ASTM Type J or K thermocouples offer more accurate sensing of process and/or sheath temperatures. A thermocouple may be inserted into the thermowell or attached to the heater's sheath.

Thermocouples are supplied with 120 inch (3050 mm) leads (longer lead lengths available). Unless otherwise specified, thermocouples are supplied with temperature ranges detailed on the *Thermocouple Types* chart.

Using a thermocouple requires an appropriate temperature and power control. These must be purchased separately. Watlow offers a wide variety of temperature and power controls to meet virtually all applications. Temperature controls can be configured to accept process variable inputs, too.

### Wattages and Voltages

Watlow routinely supplies flange immersion heaters with 240 to 480V~(ac) as well as wattages from 150 watts to one megawatt. If

### Thermostats

To provide process temperature control, Watlow offers optional single pole, single throw (SPST) and double pole, single throw (DPST) thermostats.

Unless otherwise specified,

thermostats are mounted inside the terminal enclosure. For details and ordering information, refer to **Thermostats** on **pages 423 to 425**. Please verify that the thermostat's sensing bulb O.D. is compatible with the flange heater's thermowell I.D.

Consult your Watlow representative for details.

To order, specify **Type J** or **K** thermocouple and lead length. Indicate if the thermocouple is for **process temperature sensing** or heater sheath **high-limit protection**. Please specify if the flange heater will be mounted **vertical** or **horizontal** in the tank. **If vertical, specify if the housing is on top or bottom.**

If the flange heater is part of an in-line circulation heating application, indicate flow direction relative to the heater's enclosure.

### RTDs

If your process requires greater temperature sensing accuracy than is possible with thermocouples, Watlow can also supply RTDs in DIN or JIS calibrations. Consult Watlow for details.

### Thermocouple Types

ASTM Type	Conductor Characteristics		Recommended <sup>①</sup> Temperature Range	
	Positive	Negative	°F	(°C)
J	Iron (Magnetic)	Constantan (Non-magnetic)	0 to 1000	(-20 to 540)
K	Chromel® (Non-magnetic)	Alumel® (Magnetic)	0 to 2000	(-20 to 1100)

<sup>①</sup> Type J and Type K thermocouples are rated 32 to 1382°F and 32 to 2282°F (0-750°C and 0-1250°C), respectively. Watlow does not recommend exceeding temperature ranges shown on this chart for the tubular product line.

required, Watlow will make heaters with voltage up to 600V~(ac) and wattage beyond one megawatt. For more information on special voltage

and wattage configurations, consult your Watlow representative.

### Branch Circuits

Branch circuits are subdivided by National Electrical Code (NEC) requirements to a maximum of

48 amps per circuit. Consult factory for circuit requirements other than those listed in the stock charts.

Alumel® and Chromel® are registered trademarks of the Hoskins Manufacturing Company.

## Tubular and Process Assemblies

### Flange Immersion Heaters

#### Options

##### Sheath Materials

The following sheath materials are available on WATROD and FIREBAR flange heaters:

##### Standard Sheath Materials

<b>WATROD</b>	Incoloy® 316 stainless steel Steel Copper
<b>FIREBAR</b>	Incoloy®

##### Made-to-Order Sheath Materials

<b>WATROD</b>	304 stainless steel Monel®
<b>FIREBAR</b>	304 stainless steel

##### Exotic Sheath Materials

Consult your Watlow representative for details and availability.

#### External Finishing

##### Passivation

During the manufacturing process, particles of iron or tool steel may become embedded in the stainless steel or alloy sheath. If not removed, these particles may

corrode, produce rust spots and/or contaminate the process. For critical sheath applications, passivation will remove free iron from the sheath. To order, specify **passivation**.

##### Other Finishes

Simple belt polishing and glass beading are available to meet cosmetic demands. Consult factory for details.

#### Flanges

##### Flange Sizes and Styles

**Standard:** 2<sup>Ø</sup>, 2½<sup>Ø</sup>, 3, 4, 5, 6, 8, 10, 12 and 14 inch ANSI raised face/blind flanges.

**Made-to-Order:** 16, 18, 20 and 24 inch in any recognized configuration, as well as customer specified. Over 24 inch, consult Watlow Process Systems.

##### Flange Materials

<b>Standard</b>	Carbon steel 316 stainless steel 304 stainless steel
<b>Made-to-Order</b>	Exotic materials to meet specific application needs <sup>②</sup>

##### Pressure Classes

<b>Standard</b>	150 lb
<b>Made-to-Order</b>	300 lb 600 lb Over 600 lb <sup>②</sup>

#### Gaskets

Rubber, asbestos-free and spiral wound gaskets are available for all flange sizes. Order by specifying gasket type, flange size/rating, process operating temperature and pressure.

To make the correct selection, see the *Gasket Selection* chart.

It provides a recommended gasket type and effective temperature rating.

To use this chart, multiply operating temperature by the operating pressure to arrive at "Maximum PSIG X °F." This is listed in the chart's first column.

#### Gasket Selection

Maximum PSIG X °F	Gasket Temperature °F	Gasket Type
Up to 15,000	300	Rubber
Over 250,000	700	Asbestos-Free
Over 250,000	③	Spiral Wound

③ Depends on metal gasket material.

#### Baffles

For forced circulation applications, baffles can be arranged on the heating element bundle to enhance and/or modify fluid or gas flow for better heat transfer.

For open tank or convection heating applications, standard element supports will be supplied.

To order, specify **baffles**.

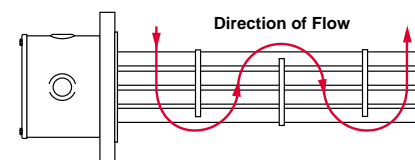

① ANSI compatible only.

② Consult Watlow Process Systems in Troy, Missouri.

Monel® is a registered trademark of Special Metals Corporation.

# Tubular and Process Assemblies

## Flange Immersion Heaters

### Application Hints

- Select the recommended heating element sheath material and watt density for the substance being heated. Use the **Supplemental Applications Chart** on **pages 263 to 266**. If unable to determine the correct heating element sheath material and type, consult your Watlow representative.
- Extend the element no-heat section completely into the fluid being heated to help prevent premature heater failure. See accompanying illustration for proper no-heat section placement.
- Locate flange heater low in the tank, but above the sludge level.

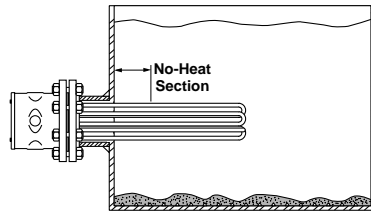

- Choose a FIREBAR element when your application requires a smaller system package or lower watt density.
- Ensure wiring integrity by keeping terminal enclosure temperature below 400°F (205°C).
- Keep electrical connections clean, dry and tight.
- Minimize problems associated with low liquid level conditions by

using low liquid level sensor or sheath temperature high-limit control.

- Periodically remove the flange assembly to inspect and clean the heating element(s). This preventive maintenance will reduce premature failure and optimize heater performance.
- Refer to the *Installation and Maintenance Instructions* for correct orientation of FIREBAR elements. This is important in air applications with customer supplied circulation tanks. Correct element orientation to flow minimizes pressure drop, increases buoyancy force and heater performance.

### Flange Immersion Heater

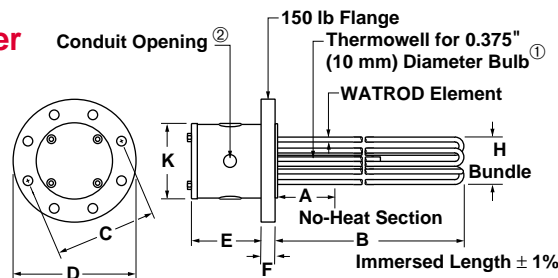

**For terminal enclosure dimensions (K and E) see page 341.**

### Flange Immersion Heater Dimensions

Element Type	Flange Size in	Flange Mounting Hole		Thermowell Length in (mm)	A Dimension in (mm)	C Dimension in (mm)	D Dimension in (mm)	F Dimension in (mm)	H Dimension in (mm)	Number of Elements	
		Size in (mm)	Number							Std	Max
WATROD	2 <sup>①</sup>	3/4 (19)	4	— —	2 (51)	4 3/4 (121)	6 (152)	5/16 (14)	2 (51)	3	3
WATROD	2 1/2 <sup>①</sup>	3/4 (19)	4	— —	3 (76)	5 1/2 (140)	7 (178)	3/8 (10)	2 1/4 (57)	3	3
WATROD	3	3/4 (19)	4	12 (305)	4 (102)	6 (152)	7 1/2 (191)	1 5/16 (24)	2 3/4 (70)	3	6
WATROD	4	3/4 (19)	8	12 (305)	4 (102)	7 1/2 (191)	9 (229)	1 5/16 (24)	3 3/8 (98)	6	6
WATROD	5	7/8 (22)	8	12 (305)	4 (102)	8 1/2 (216)	10 (254)	1 5/16 (24)	5 (127)	6	9
WATROD	6	7/8 (22)	8	12 (305)	4 (102)	9 1/2 (241)	11 (279)	1 (25)	6 (152)	12	15
WATROD	8	7/8 (22)	8	18 (457)	6 (152)	11 3/4 (298)	13 1/2 (343)	1 1/8 (29)	7 13/16 (198)	18	24
WATROD	10	1 (25)	12	18 (457)	6 (152)	14 1/4 (362)	16 (406)	1 3/16 (30)	9 3/4 (248)	27	36
WATROD	12	1 (25)	12	18 (457)	6 (152)	17 (432)	19 (483)	1 1/4 (32)	11 3/4 (298)	36	54
WATROD	14	1 1/8 (29)	12	18 (457)	6 (152)	18 3/4 (476)	21 (533)	1 3/8 (35)	12 3/4 (324)	45	72

<sup>①</sup> Thermowells are not provided on two and 2 1/2 inch units. 150 lb rating is not available on two and 2 1/2 inch stock units.

**Note:** The number and size of conduit openings will comply with the National Electrical Code standards.

# Tubular and Process Assemblies

## Flange Immersion Heaters

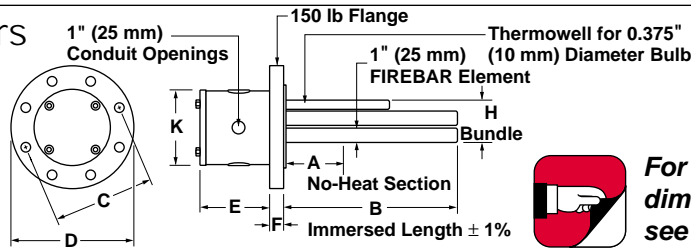

For terminal enclosure dimensions (K and E) see page 341.

### Flange Immersion Heater Dimensions

Element Type	Flange Size in	Flange Mounting Hole		Thermowell Length in (mm)	A Dimension in (mm)	C Dimension in (mm)	D Dimension in (mm)	F Dimension in (mm)	H Dimension in (mm)	Elements Standard
		Size in (mm)	Number							
FIREBAR	4	3/4 (19)	8	12 (305)	4 (102)	7 1/2 (191)	9 (229)	1 1/2 (24)	3 1/2 (98)	6
FIREBAR	6	7/8 (22)	8	12 (305)	4 (102)	9 1/2 (241)	11 (279)	1 (25)	6 (152)	15

### 6" O.D. Plate Flange—WATROD Element

WATROD Description	kW	Immersed B Dimension inch (mm)	Code No.				Est. Ship. Weight lbs (kg)
			240V~(ac) 1-Phase	240V~(ac) 3-Phase	480V~(ac) 1-Phase	480V~(ac) 3-Phase	

#### Applications: Process Water, Ethylene Glycol (50%)

45 W/in <sup>2</sup> Steel Flange 3-Copper (7 W/cm <sup>2</sup> )	4.5	16 (406)	FKC16A10②	FKC16A3②	FKC16A11②	FKC16A5	22 (10)
	9	29 (737)	FKC29A10②	FKC29A3	FKC29A11②	FKC29A5	27 (13)

#### Application: Process Water

45 W/in <sup>2</sup> Steel Flange 3-Incoloy® (7 W/cm <sup>2</sup> )	9	28 (711)	FKN28A10②	FKN28A3②	FKN28A11②	FKN28A5	27 (13)
---	---	----------	-----------	----------	-----------	---------	---------

#### Applications: Cooking Oils, Ethylene Glycol (100%)

30 W/in <sup>2</sup> Steel Flange 3-Steel (4.7 W/cm <sup>2</sup> )	6	29 (737)	FKS29A10②	FKS29A3②	FKS29A11②	FKS29A5	27 (13)
--	---	----------	-----------	----------	-----------	---------	---------

#### Applications: Medium Weight Oils, Heat Transfer Oils, Liquid Paraffin

15 W/in <sup>2</sup> ③ Steel Flange 3-Incoloy® (2.3 W/cm <sup>2</sup> )	3	28 (711)		FKN28A12②		FKN28A13②	27 (13)
---	---	----------	--	-----------	--	-----------	---------

#### Applications: Medium Weight Oils, Heat Transfer Oils, Lube Oils, Liquid Paraffin

10 W/in <sup>2</sup> ③ Steel Flange 3-Steel (1.6 W/cm <sup>2</sup> )	2	29 (737)		FKS29A12②		FKS29A13②	27 (13)
--	---	----------	--	-----------	--	-----------	---------

All flange immersion heaters are Assembly Stock unless otherwise noted.

- ② Standard
- ③ Must be operated 3-phase wye

#### Availability

**Stock:** Same day shipment

**Assembly Stock:** Five to seven working days

**Standard:** 10 working days, depending on size

# Tubular and Process Assemblies

## Flange Immersion Heaters

### 7" O.D. Plate Flange—WATROD Element

WATROD Description	kW	Immersed B Dimension inch (mm)	Code No.								Est. Ship.	
			240V~(ac) 1-Phase	No. of Circuits	240V~(ac) 3-Phase	No. of Circuits	480V~(ac) 1-Phase	No. of Circuits	480V~(ac) 3-Phase	No. of Circuits	Weight lbs (kg)	

#### Applications: Clean and Potable Water

100 W/in <sup>2</sup> Steel Flange 3-304 SS (15.5 W/cm <sup>2</sup> )	12	18 (457)	FLN18A10 <sup>②</sup>	2	FLN18A3 <sup>②</sup>	1	FLN18A11 <sup>②</sup>	1	FLN18A5	1	22 (10)

#### Applications: Clean and Potable Water

80 W/in <sup>2</sup> Steel Flange 3-304 SS (12.4 W/cm <sup>2</sup> )	9	17½ (451)	FLN17N10 <sup>②</sup>	1	FLN17N3	1	FLN17N11 <sup>②</sup>	1	FLN17N5 <sup>②</sup>	1	22 (10)
	18	30 (762)	FLN30A10 <sup>②</sup>	2	FLN30A3	1	FLN30A11 <sup>②</sup>	1	FLN30A5 <sup>②</sup>	1	27 (13)

#### Application: Process Water

60 W/in <sup>2</sup> Steel Flange 3-Incoloy <sup>®</sup> (9.3 W/cm <sup>2</sup> )	4.5	12½ (318)	FLN12J10 <sup>②</sup>	1	FLN12J3	1	FLN12J11 <sup>②</sup>	1	FLN12J5 <sup>②</sup>	1	21 (10)
--	-----	-----------	-----------------------	---	---------	---	-----------------------	---	----------------------	---	---------

#### Applications: Cooking Oils, Ethylene Glycol (100%)

30 W/in <sup>2</sup> <sup>③</sup> Steel Flange 3-Incoloy <sup>®</sup> (4.7 W/cm <sup>2</sup> )	3	17½ (451)			FLN17N12 <sup>②</sup>	1			FLN17N13 <sup>②</sup>	1	22 (10)
	4	18 (457)			FLN18A12 <sup>②</sup>	1			FLN18A13	1	22 (10)
	6	30 (762)			FLN30A12	1			FLN30A13	1	27 (13)

All flange immersion heaters are Assembly Stock unless otherwise noted.

② Standard

③ Must be operated 3-phase wye

#### Availability

**Stock:** Same day shipment

**Assembly Stock:** Five to seven working days

**Standard:** 10 working days, depending on size

# Tubular and Process Assemblies

## Flange Immersion Heaters

### 3" 150 lb ANSI Flange—WATROD Element

WATROD Description	kW	Immersed B Dimension inch (mm)	Code No.								Est. Ship.	
			240V~(ac) 1-Phase	No. of Circuits	240V~(ac) 3-Phase	No. of Circuits	480V~(ac) 1-Phase	No. of Circuits	480V~(ac) 3-Phase	No. of Circuits	Weight lbs (kg)	

#### Application: Clean Water

<b>60 W/in<sup>2</sup></b> <b>Steel Flange</b> <b>3-Copper</b> (9.3 W/cm <sup>2</sup> )	6	15½ (394)	<b>FMC715J10</b>	1	<b>FMC715J3</b>	1	<b>FMC715J11</b>	1	<b>FMC715J5</b>	1	22 (10)
	9	21½ (546)	<b>FMC721J10</b>	1	<b>FMC721J3</b>	1	<b>FMC721J11</b>	1	<b>FMC721J5</b>	1	25 (12)
	12	27 (686)			<b>FMC727A3</b>	1	<b>FMC727A11</b>	1	<b>FMC727A5</b>	1	27 (13)
	15	32½ (826)			<b>FMC732J3</b>	1	<b>FMC732J11</b>	1	<b>FMC732J5</b>	1	28 (13)
	18	38 (965)			<b>FMC738A3</b>	1	<b>FMC738A11</b>	1	<b>FMC738A5</b>	1	30 (14)
	25	51 (1295)					<b>FMC751A11</b>	1	<b>FMC751A5</b>	1	34 (16)
30	60½ (1537)					<b>FMC760J11</b> ②	1	<b>FMC760J5</b> ②	1	36 (17)	

#### Application: Process Water

<b>48 W/in<sup>2</sup></b> ⑤⑥ <b>Steel Flange</b> <b>3-Incoloy®</b> (7.5 W/cm <sup>2</sup> )	4.5	13½ (343)	<b>FMN713J10</b>	1	<b>FMN713J3</b>	1	<b>FMN713J11</b>	1	<b>FMN713J5</b>	1	22 (10)
	6	18 (457)	<b>FMN718A10</b>	1	<b>FMN718A3</b>	1	<b>FMN718A11</b>	1	<b>FMN718A5</b>	1	23 (11)
	7.5	20½ (521)	<b>FMN720J10</b>	1	<b>FMN720J3</b>	1	<b>FMN720J11</b>	1	<b>FMN720J5</b>	1	25 (12)
	9	25½ (648)	<b>FMN725J10</b>	1	<b>FMN725J3</b>	1	<b>FMN725J11</b>	1	<b>FMN725J5</b>	1	27 (13)
	12	33 (838)			<b>FMN733A3</b>	1	<b>FMN733A11</b>	1	<b>FMN733A5</b>	1	28 (13)
	15	40½ (1029)			<b>FMN740J3</b>	1	<b>FMN740J11</b>	1	<b>FMN740J5</b>	1	30 (14)
	18	48 (1219)			<b>FMN748A3</b>	1	<b>FMN748A11</b>	1	<b>FMN748A5</b>	1	32 (15)

#### Applications: Forced Air and Gases, Caustic Solutions, Degreasing Solutions

<b>23 W/in<sup>2</sup></b> ⑤⑥ <b>Steel Flange</b> <b>3-Incoloy®</b> (3.6 W/cm <sup>2</sup> )	3	18 (457)	<b>FMNA18A10</b>	1	<b>FMNA18A3</b>	1	<b>FMNA18A11</b>	1	<b>FMNA18A5</b>	1	23 (11)
	4.5	25½ (648)	<b>FMNA25J10</b>	1	<b>FMNA25J3</b>	1	<b>FMNA25J11</b>	1	<b>FMNA25J5</b>	1	27 (13)
	6	33 (838)	<b>FMNA33A10</b>	1	<b>FMNA33A3</b>	1	<b>FMNA33A11</b>	1	<b>FMNA33A5</b>	1	28 (13)
	7.5	40½ (1029)	<b>FMNA40J10</b>	1	<b>FMNA40J3</b>	1	<b>FMNA40J11</b>	1	<b>FMNA40J5</b>	1	30 (14)
	9	48 (1219)	<b>FMNA48A10</b>	1	<b>FMNA48A3</b>	1	<b>FMNA48A11</b>	1	<b>FMNA48A5</b>	1	32 (15)
	12.5	64½ (1638)			<b>FMNA64J3</b>	1	<b>FMNA64J11</b>	1	<b>FMNA64J5</b>	1	37 (17)
	15	77 (1956)			<b>FMNA77A3</b>	1	<b>FMNA77A11</b>	1	<b>FMNA77A5</b>	1	42 (19)

#### Applications: Lightweight Oils, Degreasing Solutions, Heat Transfer Oils

<b>23 W/in<sup>2</sup></b> <b>Steel Flange</b> <b>3-Steel</b> (3.6 W/cm <sup>2</sup> )	3	18 (457)	<b>FMS718A10</b>	1	<b>FMS718A3</b>	1	<b>FMS718A11</b>	1	<b>FMS718A5</b>	1	23 (11)
	4.5	25½ (648)	<b>FMS725J10</b>	1	<b>FMS725J3</b>	1	<b>FMS725J11</b>	1	<b>FMS725J5</b>	1	27 (13)
	6	33 (838)	<b>FMS733A10</b>	1	<b>FMS733A3</b>	1	<b>FMS733A11</b>	1	<b>FMS733A5</b>	1	28 (13)
	7.5	40½ (1029)	<b>FMS740J10</b>	1	<b>FMS740J3</b>	1	<b>FMS740J11</b>	1	<b>FMS740J5</b>	1	30 (14)
	9	48 (1219)	<b>FMS748A10</b>	1	<b>FMS748A3</b>	1	<b>FMS748A11</b>	1	<b>FMS748A5</b>	1	32 (15)
	12.5	64½ (1638)			<b>FMS764J3</b>	1	<b>FMS764J11</b>	1	<b>FMS764J5</b>	1	37 (17)
	15	77 (1956)			<b>FMS777A3</b>	1	<b>FMS777A11</b>	1	<b>FMS777A5</b>	1	42 (19)

CONTINUED

All flange immersion heaters are Assembly Stock unless otherwise noted.

#### Availability

**Stock:** Same day shipment

**Assembly Stock:** Five to seven working days

**Standard:** 10 working days, depending on size

② Standard

⑤ 240V~(ac) 3-phase can be rewired wye to produce ½ more kW and watt density when operated at 480V~(ac) 3-phase.

⑥ Can be rewired wye to produce ½ of the original kW and watt density (3-phase only).

# Tubular and Process Assemblies

## Flange Immersion Heaters

### 3" 150 lb ANSI Flange—WATROD Element

WATROD Description	kW	Immersed B Dimension inch (mm)	Code No.								Est. Ship.	
			240V~(ac) 1-Phase	No. of Circuits	240V~(ac) 3-Phase	No. of Circuits	480V~(ac) 1-Phase	No. of Circuits	480V~(ac) 3-Phase	No. of Circuits	Weight lbs (kg)	

#### Applications: Medium Weight Oils, Heat Transfer Oils, Liquid Paraffin

<b>16 W/in<sup>2</sup>③</b>	1.5	13½ (343)			<b>FMN713J12</b>	1			<b>FMN713J13</b>	1	22 (10)
<b>Steel Flange</b>	2	18 (457)			<b>FMN718A12</b>	1			<b>FMN718A13</b>	1	23 (11)
<b>3-Incoloy®</b>	2.5	20½ (521)			<b>FMN720J12</b>	1			<b>FMN720J13</b>	1	25 (12)
(2.5 W/cm <sup>2</sup> )	3	25½ (648)			<b>FMN725J12</b>	1			<b>FMN725J13</b>	1	27 (13)
	4	33 (838)			<b>FMN733A12</b>	1			<b>FMN733A13</b>	1	30 (14)
	5	40½ (1029)			<b>FMN740J12</b>	1			<b>FMN740J13</b>	1	30 (14)
	6	48 (1219)			<b>FMN748A12</b>	1			<b>FMN748A13</b>	1	33 (15)

#### Applications: Bunker C and #6 Fuel Oils

<b>8 W/in<sup>2</sup>③</b>	2	33 (838)			<b>FMS733A12</b>	1			<b>FMS733A13</b>	1	28 (13)
<b>Steel Flange</b>	3	48 (1219)			<b>FMS748A12</b>	1			<b>FMS748A13</b>	1	32 (15)
<b>3-Steel</b>	4	64½ (1638)			<b>FMS764J12</b>	1			<b>FMS764J13</b>	1	37 (17)
(1.3 W/cm <sup>2</sup> )	5	77 (1956)			<b>FMS777A12</b>	1			<b>FMS777A13</b>	1	42 (19)

### 4" 150 Lb ANSI Flange—WATROD Element

WATROD Description	kW	Immersed B Dimension inch (mm)	Code No.								Est. Ship.	
			240V~(ac) 1-Phase	No. of Circuits	240V~(ac) 3-Phase	No. of Circuits	480V~(ac) 1-Phase	No. of Circuits	480V~(ac) 3-Phase	No. of Circuits	Weight lbs (kg)	

#### Application: Clean Water

<b>60 W/in<sup>2</sup></b>	12	15½ (394)	<b>FOC715J10</b>	2	<b>FOC715J3</b>	1	<b>FOC715J11</b>	1	<b>FOC715J5</b>	1	31 (14)
<b>Steel Flange</b>	18	21½ (546)	<b>FOC721J10</b>	2	<b>FOC721J3</b>	1	<b>FOC721J11</b>	1	<b>FOC721J5</b>	1	34 (16)
<b>6-Copper</b>	24	27 (686)	<b>FOC727A10</b>	2	<b>FOC727A3</b>	2	<b>FOC727A11</b>	1	<b>FOC727A5</b>	1	36 (17)
(9.3 W/cm <sup>2</sup> )	30	32½ (826)			<b>FOC732J3</b>	2	<b>FOC732J11</b>	2	<b>FOC732J5</b>	1	39 (18)
	36	38 (965)			<b>FOC738A3</b>	2	<b>FOC738A11</b>	2	<b>FOC738A5</b>	1	43 (20)
	50	51 (1295)							<b>FOC751A5</b>	2	48 (22)
	60	60½ (1537)							<b>FOC760J5②</b>	2	52 (24)

#### Application: Deionized Water, Demineralized Water

<b>60 W/in<sup>2</sup></b>	12	16 (406)	<b>FOR716A10</b>	1	<b>FOR716A3</b>	1	<b>FOR716A11</b>	1	<b>FOR716A5</b>	1	31 (14)
<b>316 SS Flange</b>	18	22 (559)	<b>FOR722A10</b>	2	<b>FOR722A3</b>	1	<b>FOR722A11</b>	1	<b>FOR722A5</b>	1	34 (16)
<b>6-316 SS</b>	24	27½ (699)	<b>FOR727J10</b>	2	<b>FOR727J3</b>	2	<b>FOR727J11</b>	1	<b>FOR727J5</b>	1	36 (17)
(9.3 W/cm <sup>2</sup> )	30	33 (838)			<b>FOR733A3</b>	2	<b>FOR733A11</b>	2	<b>FOR733A5</b>	1	39 (18)
<b>Passivated</b>	36	38½ (978)			<b>FOR738J3</b>	2	<b>FOR738J11</b>	2	<b>FOR738J5</b>	1	43 (20)
	50	51½ (1308)							<b>FOR751J5</b>	2	53 (25)
	60	61 (1549)							<b>FOR761A5</b>	2	56 (26)

CONTINUED 

All flange immersion heaters are Assembly Stock unless otherwise noted.

② Standard

③ Must be operated 3-phase wye

#### Availability

**Stock:** Same day shipment

**Assembly Stock:** Five to seven working days

**Standard:** 10 working days, depending on

size

# Tubular and Process Assemblies

## Flange Immersion Heaters 4" 150 lb ANSI Flange—WATROD Element

WATROD Description	kW	Immersed B Dimension inch (mm)	Code No.								Est. Ship. Weight	
			240V~(ac) 1-Phase	No. of Circuits	240V~(ac) 3-Phase	No. of Circuits	480V~(ac) 1-Phase	No. of Circuits	480V~(ac) 3-Phase	No. of Circuits	lbs	(kg)

### Application: Process Water

<b>48 W/in<sup>2</sup></b> <sup>⑤</sup>	9	13½ (343)	<b>FON713J10</b>	1	<b>FON713J3</b>	1	<b>FON713J11</b>	1	<b>FON713J5</b>	1	29 (14)
<b>Steel Flange</b>	12	18 (457)	<b>FON718A10</b>	2	<b>FON718A3</b>	1	<b>FON718A11</b>	1	<b>FON718A5</b>	1	32 (15)
<b>6-Incoloy®</b>	15	20½ (521)	<b>FON720J10</b>	2	<b>FON720J3</b>	1	<b>FON720J11</b>	1	<b>FON720J5</b>	1	34 (16)
(7.5 W/cm <sup>2</sup> )	18	25½ (648)	<b>FON725J10</b>	2	<b>FON725J3</b>	1	<b>FON725J11</b>	1	<b>FON725J5</b>	1	36 (17)
	24	33 (838)	<b>FON733A10</b>	2	<b>FON733A3</b>	2	<b>FON733A11</b>	1	<b>FON733A5</b>	1	39 (18)
	30	40½ (1029)			<b>FON740J3</b>	2	<b>FON740J11</b>	2	<b>FON740J5</b>	1	43 (20)
	36	48 (1219)			<b>FON748A3</b>	2	<b>FON748A11</b>	2	<b>FON748A5</b>	1	48 (22)

### Applications: Forced Air and Gases, Caustic Solutions, Degreasing Solutions

<b>23 W/in<sup>2</sup></b> <sup>⑥</sup>	6	18 (457)	<b>FONA18A10</b>	1	<b>FONA18A3</b>	1	<b>FONA18A11</b>	1	<b>FONA18A5</b>	1	32 (15)
<b>Steel Flange</b>	9	25½ (648)	<b>FONA25J10</b>	1	<b>FONA25J3</b>	1	<b>FONA25J11</b>	1	<b>FONA25J5</b>	1	36 (17)
<b>6-Incoloy®</b>	12	33 (838)	<b>FONA33A10</b>	2	<b>FONA33A3</b>	1	<b>FONA33A11</b>	1	<b>FONA33A5</b>	1	39 (18)
(3.6 W/cm <sup>2</sup> )	15	40½ (1029)	<b>FONA40J10</b>	2	<b>FONA40J3</b>	1	<b>FONA40J11</b>	1	<b>FONA40J5</b>	1	43 (20)
	18	48 (1219)	<b>FONA48A10</b>	2	<b>FONA48A3</b>	1	<b>FONA48A11</b>	1	<b>FONA48A5</b>	1	48 (22)
	25	64½ (1638)			<b>FONA64J3</b>	2	<b>FONA64J11</b>	2	<b>FONA64J5</b>	1	53 (24)
	30	77 (1956)			<b>FONA77A3</b>	2	<b>FONA77A11</b>	2	<b>FONA77A5</b>	1	61 (28)

### Applications: Lightweight Oils, Degreasing Solutions, Heat Transfer Oils

<b>23 W/in<sup>2</sup></b>	6	18 (457)	<b>FOS718A10</b>	1	<b>FOS718A3</b>	1	<b>FOS718A11</b>	1	<b>FOS718A5</b>	1	32 (15)
<b>Steel Flange</b>	9	25½ (648)	<b>FOS725J10</b>	1	<b>FOS725J3</b>	1	<b>FOS725J11</b>	1	<b>FOS725J5</b>	1	36 (17)
<b>6-Steel</b>	12	33 (838)	<b>FOS733A10</b>	2	<b>FOS733A3</b>	1	<b>FOS733A11</b>	1	<b>FOS733A5</b>	1	39 (18)
(3.6 W/cm <sup>2</sup> )	15	40½ (1029)	<b>FOS740J10</b>	2	<b>FOS740J3</b>	1	<b>FOS740J11</b>	1	<b>FOS740J5</b>	1	43 (20)
	18	48 (1219)	<b>FOS748A10</b>	2	<b>FOS748A3</b>	1	<b>FOS748A11</b>	1	<b>FOS748A5</b>	1	48 (22)
	25	64½ (1638)			<b>FOS764J3</b>	2	<b>FOS764J11</b>	2	<b>FOS764J5</b>	1	53 (24)
	30	77 (1956)			<b>FOS777A3</b>	2	<b>FOS777A11</b>	2	<b>FOS777A5</b>	1	61 (28)

### Applications: Medium Weight Oils, Heat Transfer Oils, Liquid Paraffin

<b>16 W/in<sup>2</sup></b> <sup>③</sup>	3	13½ (343)			<b>FON713J12</b>	1			<b>FON713J13</b>	1	29 (14)
<b>Steel Flange</b>	4	18 (457)			<b>FON718A12</b>	1			<b>FON718A13</b>	1	32 (15)
<b>6-Incoloy®</b>	5	20½ (521)			<b>FON720J12</b>	1			<b>FON720J13</b>	1	34 (16)
(2.5 W/cm <sup>2</sup> )	6	25½ (648)			<b>FON725J12</b>	1			<b>FON725J13</b>	1	36 (17)
	8	33 (838)			<b>FON733A12</b>	1			<b>FON733A13</b>	1	39 (18)
	10	40½ (1029)			<b>FON740J12</b>	1			<b>FON740J13</b>	1	43 (20)
	12	48 (1219)			<b>FON748A12</b>	1			<b>FON748A13</b>	1	48 (22)

### Applications: Bunker C and #6 Fuel Oils

<b>8 W/in<sup>2</sup></b> <sup>③</sup>	5	40½ (1029)			<b>FOS740J12</b>	1			<b>FOS740J13</b>	1	43 (20)
<b>Steel Flange</b>	6	48 (1219)			<b>FOS748A12</b>	1			<b>FOS748A13</b>	1	48 (22)
<b>6-Steel</b>	8	64½ (1638)			<b>FOS764J12</b>	1			<b>FOS764J13</b>	1	53 (24)
(1.3 W/cm <sup>2</sup> )	10	77 (1956)			<b>FOS777A12</b>	1			<b>FOS777A13</b>	1	61 (28)

All flange immersion heaters are Assembly Stock unless otherwise noted.

#### Availability

**Stock:** Same day shipment

**Assembly Stock:** Five to seven working days

**Standard:** 10 working days, depending on size

③ Must be operated 3-phase wye

④ 240V~(ac) 3-phase can be rewired wye to produce ½ more kW and watt density when operated at 480V~(ac) 3-phase.

⑥ Can be rewired wye to produce ½ of the original kW and watt density (3-phase only).

# Tubular and Process Assemblies

## Flange Immersion Heaters

### 4" 150 lb ANSI Flange—FIREBAR Element

FIREBAR Description	kW	Immersed B Dimension inch (mm)	Code No.				Est. Ship. Weight lbs (kg)	
			240V~(ac) 3-Phase	No. of Circuits	480V~(ac) 3-Phase	No. of Circuits	lbs	(kg)

#### Applications: Process Water, Ethylene Glycol (50%)

45 W/in <sup>2</sup>	12	13 $\frac{3}{8}$ (340)	FONF13G27	1			32 (20)
304 SS Flange	15	16 (406)	FONF16A27	1			35 (20)
6-Incoloy®	18	18 $\frac{3}{8}$ (467)	FONF18G27	1			38 (21)
(7 W/cm <sup>2</sup> )	24	22 $\frac{3}{8}$ (581)	FONF22R27	2	FONF22R28	1	41 (21)
	30	27 $\frac{3}{8}$ (708)	FONF27R27	2	FONF27R28	1	44 (20)
	36	32 $\frac{3}{8}$ (835)	FONF32R27	2	FONF32R28	1	46 (21)
	48	42 $\frac{3}{8}$ (1076)			FONF42G28	2	50 (23)
	60	51 $\frac{3}{8}$ (1318)			FONF51R28	2	54 (25)

#### Applications: Cooking Oils, Ethylene Glycol (100%)

30 W/in <sup>2</sup> ⓐ	10	16 $\frac{1}{2}$ (420)	FONF16J12	1	FONF16J13	1	35 (16)
304 SS Flange	13	19 $\frac{1}{2}$ (495)	FONF19J12	1	FONF19J13	1	38 (17)
6-Incoloy®	17	24 $\frac{1}{2}$ (622)	FONF24J12	1	FONF24J13	1	41 (19)
(4.7 W/cm <sup>2</sup> )	21	30 (762)	FONF30A12	2	FONF30A13	1	44 (20)
	25.5	35 (889)	FONF35A12	2	FONF35A13	1	46 (21)
	34	45 $\frac{1}{2}$ (1156)	FONF45J12	2	FONF45J13	1	50 (23)
	43	56 (1422)			FONF56A13	2	54 (25)

#### Applications: Heat Transfer Oils, Mineral Oils, Degreasing Solutions

23 W/in <sup>2</sup> ⓐ	7.5	16 $\frac{1}{2}$ (419)	FONF16J20	1			35 (16)
304 SS Flange	10	19 $\frac{1}{2}$ (495)	FONF19J20	1			38 (18)
6-Incoloy®	12.8	24 $\frac{1}{2}$ (622)	FONF24J20	1	FONF24J19	1	41 (19)
(3.6 W/cm <sup>2</sup> )	15.8	30 (762)	FONF30A20	1	FONF30A19	1	44 (20)
	19	35 (889)	FONF35A20	1	FONF35A19	1	46 (21)
	25	45 $\frac{1}{2}$ (1156)	FONF45J20	2	FONF45J19	1	50 (23)
	32.3	56 (1422)	FONF56A20	2	FONF56A19	1	54 (25)

#### Applications: Medium Weight Oils, Heat Transfer Oils, Lube Oils, Liquid Paraffin

15 W/in <sup>2</sup> ⓐ	4	13 $\frac{3}{8}$ (340)	FONF13G29	1			32 (15)
304 SS Flange	5	16 (406)	FONF16A29	1			35 (16)
6-Incoloy®	6	18 $\frac{3}{8}$ (467)	FONF18G29	1			38 (18)
(2.3 W/cm <sup>2</sup> )	8	22 $\frac{3}{8}$ (581)	FONF22R29	1	FONF22R30	1	41 (19)
	10	27 $\frac{3}{8}$ (708)	FONF27R29	1	FONF27R30	1	44 (20)
	12	32 $\frac{3}{8}$ (835)	FONF32R29	1	FONF32R30	1	46 (21)
	16	42 $\frac{3}{8}$ (1076)	FONF42G29	1	FONF42G30	1	50 (23)
	20	51 $\frac{3}{8}$ (1318)	FONF51R29	1	FONF51R30	1	54 (25)

#### Applications: Bunker C and #6 Fuel Oils, Asphalt

8 W/in <sup>2</sup> ⓐ	2.5	16 $\frac{1}{2}$ (419)	FONF16J22	1			35 (16)
304 SS Flange	3.25	19 $\frac{1}{2}$ (495)	FONF19J22	1			38 (17)
6-Incoloy®	4.25	24 $\frac{1}{2}$ (622)	FONF24J22	1	FONF24J21	1	41 (19)
(1.3 W/cm <sup>2</sup> )	5.25	30 (762)	FONF30A22	1	FONF30A21	1	44 (20)
	6.38	35 (889)	FONF35A22	1	FONF35A21	1	46 (21)
	8.5	45 $\frac{1}{2}$ (1156)	FONF45J22	1	FONF45J21	1	50 (23)
	10.75	56 (1422)	FONF56A22	1	FONF56A21	1	54 (25)

All flange immersion heaters are Assembly Stock unless otherwise noted.

ⓐ Must be operated 3-phase wye

ⓑ Can be rewired for 1-phase

#### Availability

**Stock:** Same day shipment

**Assembly Stock:** Five to seven working days

**Standard:** 10 working days, depending on size

# Tubular and Process Assemblies

## Flange Immersion Heaters 5" 150 lb ANSI Flange—WATROD Element

WATROD Description	kW	Immersed B Dimension inch (mm)	Code No.								Est. Ship.	
			240V~(ac) 1-Phase	No. of Circuits	240V~(ac) 3-Phase	No. of Circuits	480V~(ac) 1-Phase	No. of Circuits	480V~(ac) 3-Phase	No. of Circuits	Weight lbs	(kg)

### Application: Clean Water

<b>60 W/in<sup>2</sup> Steel Flange 6-Copper</b> (9.3 W/cm <sup>2</sup> )	12	15 ½ (394)	<b>FNC715J10</b>	2	<b>FNC715J3</b>	1	<b>FNC715J11</b>	1	<b>FNC715J5</b>	1	35 (16)
	18	21 ½ (546)	<b>FNC721J10</b>	2	<b>FNC721J3</b>	1	<b>FNC721J11</b>	1	<b>FNC721J5</b>	1	38 (18)
	24	27 (686)	<b>FNC727A10</b>	3	<b>FNC727A3</b>	2	<b>FNC727A11</b>	3	<b>FNC727A5</b>	1	40 (19)
	30	32 ½ (826)			<b>FNC732J3</b>	2	<b>FNC732J11</b>	2	<b>FNC732J5</b>	1	43 (20)
	36	38 (965)			<b>FNC738A3</b>	2	<b>FNC738A11</b>	2	<b>FNC738A5</b>	1	47 (22)
	50	51 (1295)							<b>FNC751A5</b>	2	52 (24)
60	60 ½ (1537)							<b>FNC760J5</b> ®	2	56 (26)	
<b>60 W/in<sup>2</sup> Steel Flange 9-Copper</b> (9.3 W/cm <sup>2</sup> )	18	15 ½ (394)	<b>FNC715J10X</b>	3	<b>FNC715J3X</b>	1	<b>FNC715J11X</b>	1	<b>FNC715J5X</b>	1	38 (18)
	27	21 ½ (546)	<b>FNC721J10X</b>	3	<b>FNC721J3X</b>	3	<b>FNC721J11X</b>	3	<b>FNC721J5X</b>	1	42 (19)
	36	27 (686)			<b>FNC727A3X</b>	3	<b>FNC727A11X</b>	3	<b>FNC727A5X</b>	1	45 (21)
	45	32 ½ (826)			<b>FNC732J3X</b>	3	<b>FNC732J11X</b>	3	<b>FNC732J5X</b>	3	48 (22)
	54	38 (965)			<b>FNC738A3X</b>	3	<b>FNC738A11X</b>	3	<b>FNC738A5X</b>	3	53 (24)
	75	51 (1295)							<b>FNC751A5X</b>	3	60 (28)
90	60 ½ (1537)							<b>FNC760J5X</b> ®	3	66 (30)	

### Application: Process Water

<b>48 W/in<sup>2</sup> Steel Flange 6-Incoloy®</b> (7.5 W/cm <sup>2</sup> )	9	13 ½ (343)	<b>FNN713J10</b>	1	<b>FNN713J3</b>	1	<b>FNN713J11</b>	1	<b>FNN713J5</b>	1	33 (15)
	12	18 (457)	<b>FNN718A10</b>	2	<b>FNN718A3</b>	1	<b>FNN718A11</b>	1	<b>FNN718A5</b>	1	36 (17)
	15	20 ½ (521)	<b>FNN720J10</b>	2	<b>FNN720J3</b>	1	<b>FNN720J11</b>	1	<b>FNN720J5</b>	1	38 (18)
	18	25 ½ (648)	<b>FNN725J10</b>	2	<b>FNN725J3</b>	1	<b>FNN725J11</b>	1	<b>FNN725J5</b>	1	40 (19)
	24	33 (838)	<b>FNN733A10</b>	3	<b>FNN733A3</b>	2	<b>FNN733A11</b>	3	<b>FNN733A5</b>	1	43 (20)
	30	40 ½ (1029)			<b>FNN740J3</b>	2	<b>FNN740J11</b>	2	<b>FNN740J5</b>	1	47 (22)
36	48 (1219)			<b>FNN748A3</b>	2	<b>FNN748A11</b>	2	<b>FNN748A5</b>	1	52 (24)	
<b>48 W/in<sup>2</sup> Steel Flange 9-Incoloy®</b> (7.5 W/cm <sup>2</sup> )	14	13 ½ (343)	<b>FNN713J10X</b>	3	<b>FNN713J3X</b>	1	<b>FNN713J11X</b>	1	<b>FNN713J5X</b>	1	35 (16)
	18	18 (457)	<b>FNN718A10X</b>	3	<b>FNN718A3X</b>	1	<b>FNN718A11X</b>	1	<b>FNN718A5X</b>	1	39 (18)
	23	20 ½ (521)	<b>FNN720J10X</b>	3	<b>FNN720J3X</b>	3	<b>FNN720J11X</b>	1	<b>FNN720J5X</b>	1	42 (19)
	27	25 ½ (648)	<b>FNN725J10X</b>	3	<b>FNN725J3X</b>	3	<b>FNN725J11X</b>	3	<b>FNN725J5X</b>	1	45 (21)
	36	33 (838)			<b>FNN733A3X</b>	3	<b>FNN733A11X</b>	3	<b>FNN733A5X</b>	1	48 (22)
	45	40 ½ (1029)			<b>FNN740J3X</b>	3	<b>FNN740J11X</b>	3	<b>FNN740J5X</b>	3	53 (24)
54	48 (1219)			<b>FNN748A3X</b>	3	<b>FNN748A11X</b>	3	<b>FNN748A5X</b>	3	60 (28)	

### Applications: Forced Air and Gases, Caustic Solutions, Degreasing Solutions

<b>23 W/in<sup>2</sup> Steel Flange 6-Incoloy®</b> (3.6 W/cm <sup>2</sup> )	6	18 (457)	<b>FNNA18A10</b>	1	<b>FNNA18A3</b>	1	<b>FNNA18A11</b>	1	<b>FNNA18A5</b>	1	36 (17)
	9	25 ½ (648)	<b>FNNA25J10</b>	1	<b>FNNA25J3</b>	1	<b>FNNA25J11</b>	1	<b>FNNA25J5</b>	1	40 (19)
	12	33 (838)	<b>FNNA33A10</b>	2	<b>FNNA33A3</b>	1	<b>FNNA33A11</b>	1	<b>FNNA33A5</b>	1	43 (20)
	15	40 ½ (1029)	<b>FNNA40J10</b>	2	<b>FNNA40J3</b>	1	<b>FNNA40J11</b>	1	<b>FNNA40J5</b>	1	47 (22)
	18	48 (1219)	<b>FNNA48A10</b>	2	<b>FNNA48A3</b>	1	<b>FNNA48A11</b>	1	<b>FNNA48A5</b>	1	52 (24)
	25	64 ½ (1638)			<b>FNNA64J3</b>	2	<b>FNNA64J11</b>	2	<b>FNNA64J5</b>	1	57 (26)
30	77 (1956)			<b>FNNA77A3</b>	2	<b>FNNA77A11</b>	2	<b>FNNA77A5</b>	1	65 (28)	

CONTINUED

All flange immersion heaters are Assembly Stock unless otherwise noted.

#### Availability

**Stock:** Same day shipment

**Assembly Stock:** Five to seven working days

**Standard:** 10 working days, depending on size

® Standard

® 240V~(ac) 3-phase can be rewired wye to produce ½ more kW and watt density when operated at 480V~(ac) 3-phase.

® Can be rewired wye to produce ½ of the original kW and watt density (3-phase only).

# Tubular and Process Assemblies

## Flange Immersion Heaters 5" 150 lb ANSI Flange—WATROD Element

WATROD Description	kW	Immersed B Dimension inch (mm)	Code No.								Est. Ship.	
			240V~(ac) 1-Phase	No. of Circuits	240V~(ac) 3-Phase	No. of Circuits	480V~(ac) 1-Phase	No. of Circuits	480V~(ac) 3-Phase	No. of Circuits	Weight lbs (kg)	

### Applications: Forced Air and Gases, Caustic Solutions, Degreasing Solutions

23 W/in <sup>2</sup> Steel Flange 9-Incoloy® (3.6 W/cm <sup>2</sup> )	9	18 (457)	FNNA18A10X	1	FNNA18A3X	1	FNNA18A11X	1	FNNA18A5X	1	39 (18)
	14	25½ (648)	FNNA25J10X	3	FNNA25J3X	1	FNNA25J11X	1	FNNA25J5X	1	45 (21)
	18	33 (838)	FNNA33A10X	3	FNNA33A3X	1	FNNA33A11X	1	FNNA33A5X	1	48 (22)
	23	40½ (1029)	FNNA40J10X	3	FNNA40J3X	3	FNNA40J11X	1	FNNA40J5X	1	53 (24)
	27	48 (1219)	FNNA48A10X	3	FNNA48A3X	3	FNNA48A11X	3	FNNA48A5X	1	60 (28)
	38	64½ (1638)			FNNA64J3X	3	FNNA64J11X	3	FNNA64J5X	1	68 (31)
	45	77 (1956)			FNNA77A3X	3	FNNA77A11X	3	FNNA77A5X	3	78 (36)

### Applications: Lightweight Oils, Degreasing Solutions, Heat Transfer Oils

23 W/in <sup>2</sup> Steel Flange 6-Steel (3.6 W/cm <sup>2</sup> )	6	18 (457)	FNS718A10	1	FNS718A3	1	FNS718A11	1	FNS718A5	1	36 (17)
	9	25½ (648)	FNS725J10	1	FNS725J3	1	FNS725J11	1	FNS725J5	1	40 (18)
	12	33 (838)	FNS733A10	2	FNS733A3	1	FNS733A11	1	FNS733A5	1	43 (20)
	15	40½ (1029)	FNS740J10	2	FNS740J3	1	FNS740J11	1	FNS740J5	1	47 (22)
	18	48 (1219)	FNS748A10	2	FNS748A3	3	FNS748A11	1	FNS748A5 <sup>①</sup>	1	52 (24)
	25	64½ (1638)			FNS764J3	2	FNS764J11	2	FNS764J5	1	57 (26)
	30	77 (1956)			FNS777A3	2	FNS777A11	2	FNS777A5	1	65 (30)

### Applications: Medium Weight Oils, Heat Transfer Oils, Liquid Paraffin

16 W/in <sup>2</sup> Steel Flange 6-Incoloy® (2.5 W/cm <sup>2</sup> )	3	13½ (343)			FNN713J12	1			FNN713J13	1	36 (17)
	4	18 (457)			FNN718A12	1			FNN718A13	1	40 (18)
	5	20½ (521)			FNN720J12	1			FNN720J13	1	43 (20)
	6	25½ (648)			FNN725J12	1			FNN725J13	1	47 (22)
	8	33 (838)			FNN733A12	1			FNN733A13	1	52 (24)
	10	40½ (1029)			FNN740J12	1			FNN740J13	1	57 (26)
	12	48 (1219)			FNN748A12	1			FNN748A13	1	65 (30)
16 W/in <sup>2</sup> Steel Flange 9-Incoloy® (2.5 W/cm <sup>2</sup> )	4.5	13½ (343)			FNN713J12X	1			FNN713J13X	1	39 (18)
	6	18 (457)			FNN718A12X	1			FNN718A13X	1	45 (21)
	7.5	20½ (521)			FNN720J12X	1			FNN720J13X	1	48 (22)
	9	25½ (648)			FNN725J12X	1			FNN725J13X	1	53 (24)
	12	33 (838)			FNN733A12X	1			FNN733A13X	1	60 (28)
	15	40½ (1029)			FNN740J12X	1			FNN740J13X	1	68 (31)
	18	48 (1219)			FNN748A12X	1			FNN748A13X	1	78 (36)

CONTINUED 

All flange immersion heaters are Assembly Stock unless otherwise noted.

① Stock

③ Must be operated 3-phase wye

#### Availability

**Stock:** Same day shipment

**Assembly Stock:** Five to seven working days

**Standard:** 10 working days, depending on size

# Tubular and Process Assemblies

## Flange Immersion Heaters 5" 150 lb ANSI Flange—WATROD Element

WATROD Description	kW	Immersed B Dimension inch (mm)	Code No.								Est. Ship.	
			240V~(ac) 1-Phase	No. of Circuits	240V~(ac) 3-Phase	No. of Circuits	480V~(ac) 1-Phase	No. of Circuits	480V~(ac) 3-Phase	No. of Circuits	Weight lbs (kg)	

### Applications: Bunker C and #6 Fuel Oils

<b>8 W/in<sup>2</sup></b> <b>Steel Flange</b>	5	40½ (1029)			FNS740J12	1				FNS740J13	1	47 (22)
	6	48 (1219)			FNS748A12	1				FNS748A13	1	52 (24)
<b>6-Steel</b>	8	64½ (1638)			FNS764J12	1				FNS764J13	1	57 (26)
(1.3 W/cm <sup>2</sup> )	10	77 (1956)			FNS777A12	1				FNS777A13	1	65 (30)
<b>8 W/in<sup>2</sup></b> <b>Steel Flange</b>	7.5	40½ (1029)			FNS740J12X	1				FNS740J13X	1	53 (24)
	9	48 (1219)			FNS748A12X	1				FNS748A13X	1	60 (28)
<b>9-Steel</b>	12	64½ (1638)			FNS764J12X	1				FNS764J13X	1	68 (31)
(1.3 W/cm <sup>2</sup> )	15	77 (1956)			FNS777A12X	1				FNS777A13X	1	78 (36)

## 6" 150 lb ANSI Flange—WATROD Element

WATROD Description	kW	Immersed B Dimension inch (mm)	Code No.								Est. Ship.	
			240V~(ac) 1-Phase	No. of Circuits	240V~(ac) 3-Phase	No. of Circuits	480V~(ac) 1-Phase	No. of Circuits	480V~(ac) 3-Phase	No. of Circuits	Weight lbs (kg)	

### Application: Clean Water

<b>60 W/in<sup>2</sup></b> <b>Steel Flange</b>	24	15¾ (391)	FPC715G10	3	FPC715G3	2	FPC715G11	2	FPC715G5	1	73 (33)
	36	21¾ (543)	FPC721G10	4	FPC721G3	2	FPC721G11	2	FPC721G5	1	78 (36)
<b>12-Copper</b>	48	26¾ (683)			FPC726R3	4	FPC726R11	3	FPC726R5	2	81 (37)
(9.3 W/cm <sup>2</sup> )	60	32¾ (822)			FPC732G3	4	FPC732G11	3	FPC732G5	2	85 (39)
	72	37¾ (962)			FPC737R3	4			FPC737R5	2	92 (42)
	100	50¾ (1292)							FPC750R5	4	100 (45)
	120	60¾ (1534)							FPC760G5 <sup>Ⓜ</sup>	4	110 (50)
<b>60 W/in<sup>2</sup></b> <b>Steel Flange</b>	30	15¾ (391)	FPC715G10X	3	FPC715G3X	5	FPC715G11X	3	FPC715G5X	1	76 (35)
	45	21¾ (543)	FPC721G10X	5	FPC721G3X	5	FPC721G11X	3	FPC721G5X	1	82 (38)
<b>15-Copper</b>	60	26¾ (683)			FPC726R3X	5	FPC726R11X	3	FPC726R5X	5	85 (39)
(9.3 W/cm <sup>2</sup> )	75	32¾ (822)			FPC732G3X	5	FPC732G11X	5	FPC732G5X	5	90 (41)
	90	37¾ (962)			FPC737R3X	5			FPC737R5X	5	98 (45)
	125	50¾ (1292)							FPC750R5X	5	108 (49)
	150	60¾ (1534)							FPC760G5X <sup>Ⓜ</sup>	5	120 (55)

### Application: Deionized Water, Demineralized Water

<b>60 W/in<sup>2</sup></b> <b>316 SS Flange</b>	24	15¾ (400)	FPR715N10	3	FPR715N3	2	FPR715N11	2	FPR715N5	1	73 (33)
	36	21¾ (552)	FPR721N10	4	FPR721N3	2	FPR721N11	3	FPR721N5	1	78 (36)
<b>12-316 SS</b>	48	27¾ (692)			FPR727E3	4	FPR727E11	3	FPR727E5	2	81 (37)
(9.3 W/cm <sup>2</sup> )	60	32¾ (832)			FPR732N3	4	FPR732N11	3	FPR732N5	2	85 (39)
Passivated	72	38¾ (972)			FPR738E3	4			FPR738E5	2	92 (42)
	100	51¾ (1302)							FPR751E5	4	100 (46)
	120	60¾ (1543)							FPR760N5	4	110 (50)

CONTINUED

All flange immersion heaters are Assembly Stock unless otherwise noted.

Ⓜ Standard  
Ⓝ Must be operated 3-phase wye

#### Availability

**Stock:** Same day shipment

**Assembly Stock:** Five to seven working days

**Standard:** 10 working days, depending on size

# Tubular and Process Assemblies

## Flange Immersion Heaters

### 6" 150 Lbs ANSI Flange—WATROD Element

WATROD Description	kW	Immersed B Dimension inch (mm)	Code No.								Est. Ship.	
			240V~(ac) 1-Phase	No. of Circuits	240V~(ac) 3-Phase	No. of Circuits	480V~(ac) 1-Phase	No. of Circuits	480V~(ac) 3-Phase	No. of Circuits	Weight lbs (kg)	

#### Application: Deionized Water, Demineralized Water

60 W/in <sup>2</sup>	30	15% (400)	FPR715N10X	3	FPR715N3X	5	FPR715N11X	3	FPR715N5X	1	76 (35)
316 SS Flange	45	21% (552)	FPR721N10X	5	FPR721N3X	5	FPR721N11X	3	FPR721N5X	5	82 (38)
15-316 SS (9.3 W/cm <sup>2</sup> )	60	27% (692)			FPR727E3X	5	FPR727E11X	3	FPR727E5X	5	85 (39)
	75	32% (832)			FPR732N3X	5	FPR732N11X	5	FPR732N5X	5	90 (41)
Passivated	90	38% (972)			FPR738E3X	5			FPR738E5X	5	98 (45)
	125	51% (1302)							FPR751E5X	5	108 (49)
	150	60% (1543)							FPR760N5X	5	120 (55)

#### Application: Process Water

48 W/in <sup>2</sup> ® Steel Flange 12-Incoloy® (7.5 W/cm <sup>2</sup> )	18	13% (340)	FPN713G10	2	FPN713G3	1	FPN713G11	1	FPN713G5	1	73 (33)
	24	17% (454)	FPN717R10	3	FPN717R3	2	FPN717R11	2	FPN717R5	1	75 (34)
	30	20% (518)	FPN720G10	3	FPN720G3	2	FPN720G11	2	FPN720G5	1	78 (36)
	36	25% (645)	FPN725G10	4	FPN725G3	2	FPN725G11	2	FPN725G5	1	81 (37)
	48	32% (835)			FPN732R3	4	FPN732R11	3	FPN732R5	2	85 (39)
	60	40% (1026)			FPN740G3	4	FPN740G11	3	FPN740G5	2	92 (42)
48 W/in <sup>2</sup> Steel Flange 15-Incoloy® (7.5 W/cm <sup>2</sup> )	72	47% (1216)			FPN747R3	4			FPN747R5	2	100 (46)
	23	13% (340)	FPN713G10X	3	FPN713G3X	5	FPN713G11X	1	FPN713G5X	1	76 (35)
	30	17% (454)	FPN717R10X	3	FPN717R3X	5	FPN717R11X	3	FPN717R5X	1	78 (36)
	38	20% (518)	FPN720G10X	5	FPN720G3X	5	FPN720G11X	3	FPN720G5X	1	82 (38)
	45	25% (645)	FPN725G10X	5	FPN725G3X	5	FPN725G11X	3	FPN725G5X	5	85 (39)
	60	32% (835)			FPN732R3X	5	FPN732R11X	3	FPN732R5X	5	90 (41)
23 W/in <sup>2</sup> Steel Flange 15-Incoloy® (3.6 W/cm <sup>2</sup> )	75	40% (1026)			FPN740G3X	5	FPN740G11X	5	FPN740G5X	5	98 (45)
	90	47% (1216)			FPN747R3X	5			FPN747R5X	5	108 (49)

#### Applications: Forced Air and Gases, Caustic Solutions, Degreasing Solutions

23 W/in <sup>2</sup> ® Steel Flange 12-Incoloy® (3.6 W/cm <sup>2</sup> )	12	17% (454)	FPNA17R10	2	FPNA17R3	1	FPNA17R11	1	FPNA17R5	1	75 (34)
	18	25% (645)	FPNA25G10	2	FPNA25G3	1	FPNA25G11	1	FPNA25G5	1	81 (37)
	24	32% (835)	FPNA32R10	3	FPNA32R3	2	FPNA32R11	2	FPNA32R5	1	85 (39)
	30	40% (1026)	FPNA40G10	3	FPNA40G3	2	FPNA40G11	1	FPNA40G5	1	92 (42)
	36	47% (1216)	FPNA47R10	4	FPNA47R3	2	FPNA47R11	2	FPNA47R5	1	100 (46)
	50	64% (1635)			FPNA64G3	4	FPNA64G11	3	FPNA64G5	2	110 (50)
23 W/in <sup>2</sup> Steel Flange 15-Incoloy® (3.6 W/cm <sup>2</sup> )	60	76% (1953)			FPNA76R3	4	FPNA76R11	3	FPNA76R5	2	118 (54)
	15	17% (454)	FPNA17R10X	3	FPNA17R3X	1	FPNA17R11X	1	FPNA17R5X	1	78 (36)
	23	25% (645)	FPNA25G10X	3	FPNA25G3X	5	FPNA25G11X	1	FPNA25G5X	1	85 (39)
	30	32% (835)	FPNA32R10X	3	FPNA32R3X	5	FPNA32R11X	3	FPNA32R5X	1	90 (41)
	38	40% (1026)	FPNA40G10X	5	FPNA40G3X	5	FPNA40G11X	3	FPNA40G5X	1	98 (45)
	45	47% (1216)	FPNA47R10X	5	FPNA47R3X	5	FPNA47R11X	3	FPNA47R5X	5	108 (49)
15-Incoloy® (3.6 W/cm <sup>2</sup> )	63	64% (1635)			FPNA64G3X	5	FPNA64G11X	3	FPNA64G5X	5	120 (55)
	75	76% (1953)			FPNA76R3X	5	FPNA76R11X	5	FPNA76R5X	5	131 (60)

CONTINUED 

All flange immersion heaters are Assembly Stock unless otherwise noted.

#### Availability

**Stock:** Same day shipment

**Assembly Stock:** Five to seven working days

**Standard:** 10 working days, depending on size

⑤ 240V~(ac) 3-phase can be rewired wye to produce ⅓ more kW and watt density when operated at 480V~(ac) 3-phase.

⑥ Can be rewired wye to produce ⅓ of the original kW and watt density (3-phase only).

# Tubular and Process Assemblies

## Flange Immersion Heaters 6" 150 lb ANSI Flange—WATROD Element

WATROD Description	kW	Immersed B Dimension inch (mm)	Code No.								Est. Ship.	
			240V~(ac) 1-Phase	No. of Circuits	240V~(ac) 3-Phase	No. of Circuits	480V~(ac) 1-Phase	No. of Circuits	480V~(ac) 3-Phase	No. of Circuits	Weight lbs	(kg)

### Applications: Lightweight Oils, Degreasing Solutions, Heat Transfer Oils

<b>23 W/in<sup>2</sup> Steel Flange 12-Steel</b> (3.6 W/cm <sup>2</sup> )	12	17% (454)	<b>FPS717R10</b>	2	<b>FPS717R3</b>	1	<b>FPS717R11</b>	1	<b>FPS717R5</b>	1	75 (34)
	18	25% (645)	<b>FPS725G10</b>	2	<b>FPS725G3</b>	1	<b>FPS725G11</b>	1	<b>FPS725G5</b>	1	81 (37)
	24	32% (835)	<b>FPS732R10</b>	3	<b>FPS732R3</b>	2	<b>FPS732R11</b>	2	<b>FPS732R5</b>	1	85 (39)
	30	40% (1026)	<b>FPS740G10</b>	3	<b>FPS740G3</b>	2	<b>FPS740G11</b>	2	<b>FPS740G5</b>	1	92 (42)
	36	47% (1216)	<b>FPS747R10</b>	4	<b>FPS747R3</b>	2	<b>FPS747R11</b>	2	<b>FPS747R5</b>	1	100 (46)
	50	64% (1635)			<b>FPS764G3</b>	4	<b>FPS764G11</b>	3	<b>FPS764G5</b>	2	110 (50)
<b>23 W/in<sup>2</sup> Steel Flange 15-Steel</b> (3.6 W/cm <sup>2</sup> )	60	76% (1953)			<b>FPS776R3</b>	4	<b>FPS776R11</b>	3	<b>FPS776R5</b>	2	118 (54)
	15	17% (454)	<b>FPS717R10X</b>	3	<b>FPS717R3X</b>	1	<b>FPS717R11X</b>	1	<b>FPS717R5X</b>	1	78 (36)
	23	25% (645)	<b>FPS725G10X</b>	3	<b>FPS725G3X</b>	5	<b>FPS725G11X</b>	1	<b>FPS725G5X</b>	1	85 (39)
	30	32% (835)	<b>FPS732R10X</b>	3	<b>FPS732R3X</b>	5	<b>FPS732R11X</b>	3	<b>FPS732R5X</b>	1	90 (41)
	38	40% (1026)	<b>FPS740G10X</b>	5	<b>FPS740G3X</b>	5	<b>FPS740G11X</b>	3	<b>FPS740G5X</b>	1	98 (45)
	45	47% (1216)	<b>FPS747R10X</b>	5	<b>FPS747R3X</b>	5	<b>FPS747R11X</b>	3	<b>FPS747R5X</b>	5	108 (49)
63	64% (1635)			<b>FPS764G3X</b>	5	<b>FPS764G11X</b>	3	<b>FPS764G5X</b>	5	120 (55)	
75	76% (1953)			<b>FPS776R3X</b>	5	<b>FPS776R11X</b>	5	<b>FPS776R5X</b>	5	131 (60)	

### Applications: Medium Weight Oils, Heat Transfer Oils, Liquid Paraffin

<b>16 W/in<sup>2</sup> Steel Flange 12-Incoloy<sup>®</sup></b> (2.5 W/cm <sup>2</sup> )	6	13% (340)			<b>FPN713G12</b>	1		<b>FPN713G13</b>	1	73 (33)
	8	17% (454)			<b>FPN717R12</b>	1		<b>FPN717R13</b>	1	75 (34)
	10	20% (518)			<b>FPN720G12</b>	1		<b>FPN720G13</b>	1	78 (36)
	12	25% (645)			<b>FPN725G12</b>	1		<b>FPN725G13</b>	1	81 (37)
	16	32% (835)			<b>FPN732R12</b>	1		<b>FPN732R13</b>	1	85 (39)
	20	40% (1026)			<b>FPN740G12</b>	2		<b>FPN740G13</b>	1	92 (42)
<b>16 W/in<sup>2</sup> Steel Flange 15-Incoloy<sup>®</sup></b> (2.5 W/cm <sup>2</sup> )	24	47% (1216)			<b>FPN747R12</b>	2		<b>FPN747R13</b>	1	100 (46)
	7.5	13% (340)			<b>FPN713G12X</b>	1		<b>FPN713G13X</b>	1	76 (35)
	10	17% (454)			<b>FPN717R12X</b>	1		<b>FPN717R13X</b>	1	78 (36)
	12.5	20% (518)			<b>FPN720G12X</b>	1		<b>FPN720G13X</b>	1	82 (38)
	15	25% (645)			<b>FPN725G12X</b>	1		<b>FPN725G13X</b>	1	85 (39)
	20	32% (835)			<b>FPN732R12X</b>	5		<b>FPN732R13X</b>	1	90 (41)
25	40% (1026)			<b>FPN740G12X</b>	5		<b>FPN740G13X</b>	1	98 (45)	
30	47% (1216)			<b>FPN747R12X</b>	5		<b>FPN747R13X</b>	1	108 (49)	

### Applications: Bunker C and #6 Fuel Oils

<b>8 W/in<sup>2</sup> Steel Flange 12-Steel</b> (1.3 W/cm <sup>2</sup> )	8	32% (835)			<b>FPS732R12</b>	1		<b>FPS732R13</b>	1	85 (39)
	10	40% (1026)			<b>FPS740G12</b>	1		<b>FPS740G13</b>	1	92 (42)
	12	47% (1216)			<b>FPS747R12</b>	1		<b>FPS747R13</b>	1	100 (46)
	16.5	64% (1635)			<b>FPS764G12</b>	1		<b>FPS764G13</b>	1	110 (50)
	20	76% (1953)			<b>FPS776R12</b>	2		<b>FPS776R13</b>	1	118 (54)
<b>8 W/in<sup>2</sup> Steel Flange 15-Steel</b> (1.3 W/cm <sup>2</sup> )	10	32% (835)			<b>FPS732R12X</b>	1		<b>FPS732R13X</b>	1	90 (41)
	12.5	40% (1026)			<b>FPS740G12X</b>	1		<b>FPS740G13X</b>	1	98 (45)
	15	47% (1216)			<b>FPS747R12X</b>	1		<b>FPS747R13X</b>	1	108 (49)
	21	64% (1635)			<b>FPS764G12X</b>	5		<b>FPS764G13X</b>	1	120 (55)
	25	76% (1953)			<b>FPS776R12X</b>	5		<b>FPS776R13X</b>	1	131 (60)

All flange immersion heaters are Assembly Stock unless otherwise noted.

③ Must be operated 3-phase wye

#### Availability

**Stock:** Same day shipment

**Assembly Stock:** Five to seven working days

**Standard:** 10 working days, depending on size

# Tubular and Process Assemblies

## Flange Immersion Heaters

### 6" 150 lb ANSI Flange—FIREBAR Element

FIREBAR Description	kW	Immersed B Dimension inch (mm)	Code No.				Est. Ship.	
			240V~(ac) 3-Phase	No. of Circuits	480V~(ac) 3-Phase	No. of Circuits	lbs	(kg)

#### Applications: Process Water, Ethylene Glycol (50%)

45 W/in <sup>2</sup> 304 SS Flange 15-Incoloy® (7 W/cm <sup>2</sup> )	30	13½ (340)	FPNF13G27				78 (36)
	37.5	16 (406)	FPNF16A27	5			81 (37)
	45	18½ (467)	FPNF18G27	5			84 (38)
	60	22½ (581)	FPNF22R27	5	FPNF22R28	5	87 (40)
	75	27½ (708)	FPNF27R27	5	FPNF27R28	5	91 (42)
	90	32½ (835)	FPNF32R27	5	FPNF32R28	5	95 (43)
	120	42½ (1076)			FPNF42G28	5	106 (48)
150	51½ (1318)			FPNF51R28	5	116 (53)	

#### Applications: Cooking Oils, Ethylene Glycol (100%)

30 W/in <sup>2</sup> ③ 304 SS Flange 15-Incoloy® (4.7 W/cm <sup>2</sup> )	25	16½ (419)	FPNF16J12	5	FPNF16J13	5	81 (37)
	32	19½ (495)	FPNF19J12	5	FPNF19J13	5	84 (38)
	42	24½ (622)	FPNF24J12	5	FPNF24J13	5	87 (40)
	52	30 (762)	FPNF30A12	5	FPNF30A13	5	91 (42)
	64	35 (889)	FPNF35A12	5	FPNF35A13	5	95 (43)
	85	45½ (1156)	FPNF45J12	5	FPNF45J13	5	106 (48)
	110	56 (1422)			FPNF56A13	5	116 (53)

#### Applications: Heat Transfer Oils, Mineral Oils, Degreasing Solutions

23 W/in <sup>2</sup> ④ 304 SS Flange 15-Incoloy® (3.6 W/cm <sup>2</sup> )	19	16½ (419)	FPNF16J20	5			81 (37)
	24	19½ (495)	FPNF19J20	5			84 (38)
	32	24½ (622)	FPNF24J20	5	FPNF24J19	5	87 (40)
	40	30 (762)	FPNF30A20	5	FPNF30A19	5	91 (42)
	48	35 (889)	FPNF35A20	5	FPNF35A19	5	95 (43)
	64	45½ (1156)	FPNF45J20	5	FPNF45J19	5	106 (48)
	80	56 (1422)	FPNF56A20	5	FPNF56A19	5	116 (53)

#### Applications: Medium Weight Oils, Heat Transfer Oils, Liquid Paraffin

15 W/in <sup>2</sup> ③ 304 SS Flange 15-Incoloy® (2.3 W/cm <sup>2</sup> )	10	13½ (340)	FPNF13G29	5			78 (36)
	12.5	16 (406)	FPNF16A29	5			81 (37)
	15	18½ (467)	FPNF18G29	5			84 (38)
	20	22½ (581)	FPNF22R29	5	FPNF22R30	5	87 (40)
	25	27½ (708)	FPNF27R29	5	FPNF27R30	5	91 (42)
	30	32½ (835)	FPNF32R29	5	FPNF32R30	5	95 (43)
	40	42½ (1076)	FPNF42G29	5	FPNF42G30	5	106 (48)
50	51½ (1318)	FPNF51R29	5	FPNF51R30	5	116 (53)	

#### Applications: Bunker C and #6 Fuel Oils, Asphalt

8 W/in <sup>2</sup> ③ 304 SS Flange 15-Incoloy® (1.3 W/cm <sup>2</sup> )	6.3	16½ (419)	FPNF16J22	5			81 (37)
	8.1	19½ (495)	FPNF19J22	5			84 (38)
	10.6	24½ (622)	FPNF24J22	5	FPNF24J21	5	87 (40)
	13.1	30 (762)	FPNF30A22	5	FPNF30A21	5	91 (42)
	16	35 (889)	FPNF35A22	5	FPNF35A21	5	95 (43)
	21.3	45½ (1156)	FPNF45J22	5	FPNF45J21	5	106 (48)
	26	56 (1422)	FPNF56A22	5	FPNF56A21	5	116 (53)

All flange immersion heaters are Assembly Stock unless otherwise noted.

③ Must be operated 3-phase wye.  
④ Can be rewired for 1-phase.

#### Availability

**Stock:** Same day shipment

**Assembly Stock:** Five to seven working days

**Standard:** 10 working days, depending on size

# Tubular and Process Assemblies

## Flange Immersion Heaters 8" 150 lb ANSI Flange—WATROD Element

WATROD Description	kW	Immersed B Dimension inch (mm)	Code No.								Est. Ship.	
			240V~(ac) 1-Phase	No. of Circuits	240V~(ac) 3-Phase	No. of Circuits	480V~(ac) 1-Phase	No. of Circuits	480V~(ac) 3-Phase	No. of Circuits	lbs	(kg)

### Application: Clean Water

<b>60 W/in<sup>2</sup> Steel Flange 18-Copper</b> (9.3 W/cm <sup>2</sup> )	50	21 3/8 (553)			<b>FRC721N3</b> Ⓜ	3	<b>FRC721N11</b>	3	<b>FRC721N5</b>	2	118 (54)
	75	29 3/8 (756)			<b>FRC729N3</b> Ⓜ	6			<b>FRC729N5</b> Ⓜ	2	126 (58)
	100	37 3/8 (946)			<b>FRC737E3</b> Ⓜ	6			<b>FRC737E5</b>	3	130 (59)
	125	45 3/8 (1149)			<b>FRC745E3</b> Ⓜ	6			<b>FRC745E5</b> Ⓜ	6	132 (60)
	150	52 3/8 (1340)							<b>FRC752N5</b> Ⓜ	6	137 (63)
	175	60 3/8 (1543)							<b>FRC760N5</b> Ⓜ	6	144 (66)
200	68 3/8 (1734)							<b>FRC768E5</b> Ⓜ	6	149 (68)	

### Application: Process Water

<b>48 W/in<sup>2</sup> Steel Flange 18-Incoloy<sup>®</sup></b> (7.5 W/cm <sup>2</sup> )	50	25 3/8 (654)			<b>FRN725N3</b> Ⓜ	3	<b>FRN725N11</b> Ⓜ	3	<b>FRN725N5</b> Ⓜ	2	121 (55)
	75	35 3/8 (908)			<b>FRN735N3</b> Ⓜ	6			<b>FRN735N5</b> Ⓜ	2	130 (59)
	100	44 3/8 (1124)			<b>FRN744E3</b>	6			<b>FRN744E5</b>	3	132 (60)
	125	54 11/16 (1389)			<b>FRN754M3</b> Ⓜ	6			<b>FRN754M5</b> Ⓜ	6	140 (64)
	150	63 11/16 (1617)							<b>FRN763M5</b> Ⓜ	6	145 (66)
	175	73 3/8 (1859)							<b>FRN773D5</b>	6	151 (69)
200	82 11/16 (2100)							<b>FRN782M5</b> Ⓜ	6	157 (72)	
<b>48 W/in<sup>2</sup> Steel Flange 24-Incoloy<sup>®</sup></b> (7.5 W/cm <sup>2</sup> )	67	26 3/8 (665)			<b>FRN726D3X</b> Ⓜ	4	<b>FRN726D11X</b> Ⓜ	3	<b>FRN726D5X</b> Ⓜ	2	129 (59)
	100	36 3/8 (919)			<b>FRN736D3X</b> Ⓜ	8			<b>FRN736D5X</b> Ⓜ	4	142 (65)
	133	44 11/16 (1135)			<b>FRN744M3X</b> Ⓜ	8			<b>FRN744M5X</b> Ⓜ	4	147 (67)
	167	54 11/16 (1389)			<b>FRN754M3X</b> Ⓜ	8			<b>FRN754M5X</b> Ⓜ	8	158 (72)
	200	63 11/16 (1618)							<b>FRN763M5X</b> Ⓜ	8	166 (76)
	233	73 3/8 (1859)							<b>FRN773D5X</b>	8	175 (80)
267	82 11/16 (2100)							<b>FRN782M5X</b> Ⓜ	8	184 (84)	

### Application: Forced Air and Gases, Caustic Solutions, Degreasing Solutions

<b>23 W/in<sup>2</sup> Steel Flange 18-Incoloy<sup>®</sup></b> (3.6 W/cm <sup>2</sup> )	30	32 3/8 (832)	<b>FRNA32N10</b> Ⓜ	3	<b>FRNA32N3</b> Ⓜ	2	<b>FRNA32N11</b> Ⓜ	2	<b>FRNA32N5</b> Ⓜ	1	130 (59)		
	40	43 3/8 (1099)			<b>FRNA43E3</b> Ⓜ	3			<b>FRNA43E11</b> Ⓜ	2	<b>FRNA43E5</b> Ⓜ	2	132 (60)
	50	51 11/16 (1313)			<b>FRNA51M3</b>	3			<b>FRNA51M11</b>	3	<b>FRNA51M5</b>	2	137 (63)
<b>23 W/in<sup>2</sup> Steel Flange 24-Incoloy<sup>®</sup></b> (3.6 W/cm <sup>2</sup> )	40	33 3/8 (843)	<b>FRNA33D10X</b> Ⓜ	4	<b>FRNA33D3X</b> Ⓜ	4	<b>FRNA33D11X</b> Ⓜ	2	<b>FRNA33D5X</b> Ⓜ	2	142 (65)		
	53	43 11/16 (1110)			<b>FRNA43M3X</b> Ⓜ	4			<b>FRNA43M11X</b> Ⓜ	3	<b>FRNA43M5X</b> Ⓜ	2	147 (67)
	67	51 11/16 (1313)			<b>FRNA51M3X</b> Ⓜ	4			<b>FRNA51M11X</b> Ⓜ	3	<b>FRNA51M5X</b> Ⓜ	2	154 (70)

CONTINUED

All flange immersion heaters are Assembly Stock unless otherwise noted.

#### Availability

**Stock:** Same day shipment

**Assembly Stock:** Five to seven working days

**Standard:** 10 working days, depending on size

Truck Shipment only

Ⓜ Standard

Ⓟ 240V~(ac) 3-phase can be rewired wye to produce 1/2 more kW and watt density when operated at 480V~(ac) 3-phase.

Ⓠ Can be rewired wye to produce 1/2 of the original kW and watt density (3-phase only).

# Tubular and Process Assemblies

## Flange Immersion Heaters

### 8" 150 lb ANSI Flange—WATROD Element

WATROD Description	kW	Immersed B Dimension inch (mm)	Code No.								Est. Ship.	
			240V~(ac) 1-Phase	No. of Circuits	240V~(ac) 3-Phase	No. of Circuits	480V~(ac) 1-Phase	No. of Circuits	480V~(ac) 3-Phase	No. of Circuits	Weight lbs	(kg)

#### Applications: Lightweight Oils, Degreasing Solutions, Heat Transfer Oils

<b>23 W/in<sup>2</sup> Steel Flange 18-Steel</b> (3.6 W/cm <sup>2</sup> )	30	32 <sup>3</sup> / <sub>16</sub> (832)	FRS732N10 <sup>Ⓜ</sup>	3	FRS732N3 <sup>Ⓜ</sup>	2	FRS732N11 <sup>Ⓜ</sup>	2	FRS732N5 <sup>Ⓜ</sup>	1	130 (59)
	40	43 <sup>1</sup> / <sub>16</sub> (1099)			FRS743E3 <sup>Ⓜ</sup>	3	FRS743E11 <sup>Ⓜ</sup>	2	FRS743E5	2	132 (60)
	50	51 <sup>1</sup> / <sub>16</sub> (1313)			FRS751M3	3	FRS751M11	3	FRS751M5	2	137 (63)
	60	62 <sup>3</sup> / <sub>16</sub> (1580)			FRS762D3 <sup>Ⓜ</sup>	6	FRS762D11 <sup>Ⓜ</sup>	3	FRS762D5 <sup>Ⓜ</sup>	2	154 (70)
	70	70 <sup>1</sup> / <sub>16</sub> (1795)			FRS770M3 <sup>Ⓜ</sup>	6	FRS770M11	6	FRS770M5	2	160 (73)
	80	79 <sup>1</sup> / <sub>16</sub> (2024)			FRS779M3 <sup>Ⓜ</sup>	6			FRS779M5 <sup>Ⓜ</sup>	3	172 (78)
<b>23 W/in<sup>2</sup> Steel Flange 24-Steel</b> (3.6 W/cm <sup>2</sup> )	40	33 <sup>3</sup> / <sub>16</sub> (843)	FRS733D10X <sup>Ⓜ</sup>	4	FRS733D3X <sup>Ⓜ</sup>	4	FRS733D11X <sup>Ⓜ</sup>	2	FRS733D5X <sup>Ⓜ</sup>	2	142 (65)
	53	43 <sup>1</sup> / <sub>16</sub> (1110)			FRS743M3X <sup>Ⓜ</sup>	4	FRS743M11X <sup>Ⓜ</sup>	3	FRS743M5X <sup>Ⓜ</sup>	2	147 (67)
	67	51 <sup>1</sup> / <sub>16</sub> (1313)			FRS751M3X <sup>Ⓜ</sup>	4	FRS751M11X <sup>Ⓜ</sup>	3	FRS751M5X <sup>Ⓜ</sup>	2	154 (70)
	80	62 <sup>3</sup> / <sub>16</sub> (1580)			FRS762D3X <sup>Ⓜ</sup>	8	FRS762D11X <sup>Ⓜ</sup>	4	FRS762D5X <sup>Ⓜ</sup>	4	166 (76)
	93	70 <sup>1</sup> / <sub>16</sub> (1796)			FRS770M3X <sup>Ⓜ</sup>	8	FRS770M11X <sup>Ⓜ</sup>	6	FRS770M5X <sup>Ⓜ</sup>	4	175 (80)
	107	79 <sup>1</sup> / <sub>16</sub> (2024)			FRS779M3X <sup>Ⓜ</sup>	8			FRS779M5X <sup>Ⓜ</sup>	4	181 (82)

#### Applications: Medium Weight Oils, Heat Transfer Oils, Liquid Paraffin

<b>16 W/in<sup>2</sup> Steel Flange 18-Incoloy<sup>®</sup></b> (2.5 W/cm <sup>2</sup> )	17	25 <sup>3</sup> / <sub>16</sub> (654)			FRN725N12 <sup>Ⓜ</sup>	1			FRN725N13 <sup>Ⓜ</sup>	1	121 (55)
	25	35 <sup>3</sup> / <sub>16</sub> (908)			FRN735N12 <sup>Ⓜ</sup>	2			FRN735N13 <sup>Ⓜ</sup>	1	130 (59)
	33	44 <sup>3</sup> / <sub>16</sub> (1124)			FRN744E12 <sup>Ⓜ</sup>	2			FRN744E13	1	132 (60)
	42	54 <sup>1</sup> / <sub>16</sub> (1389)			FRN754M12 <sup>Ⓜ</sup>	3			FRN754M13 <sup>Ⓜ</sup>	2	140 (64)
	50	63 <sup>1</sup> / <sub>16</sub> (1618)							FRN763M13 <sup>Ⓜ</sup>	2	145 (66)
	58	73 <sup>3</sup> / <sub>16</sub> (1859)							FRN773D13	2	151 (69)
67	82 <sup>1</sup> / <sub>16</sub> (2100)							FRN782M13 <sup>Ⓜ</sup>	2	157 (72)	
<b>16 W/in<sup>2</sup> Steel Flange 24-Incoloy<sup>®</sup></b> (2.5 W/cm <sup>2</sup> )	23	26 <sup>3</sup> / <sub>16</sub> (665)			FRN726D12X <sup>Ⓜ</sup>	2			FRN726D13X <sup>Ⓜ</sup>	1	129 (59)
	33	36 <sup>3</sup> / <sub>16</sub> (919)			FRN736D12X <sup>Ⓜ</sup>	2			FRN736D13X <sup>Ⓜ</sup>	1	142 (65)
	44	44 <sup>1</sup> / <sub>16</sub> (1135)			FRN744M12X <sup>Ⓜ</sup>	4			FRN744M13X <sup>Ⓜ</sup>	2	147 (67)
	56	54 <sup>1</sup> / <sub>16</sub> (1389)			FRN754M12X <sup>Ⓜ</sup>	4			FRN754M13X <sup>Ⓜ</sup>	2	158 (72)
	67	63 <sup>1</sup> / <sub>16</sub> (1618)							FRN763M13X <sup>Ⓜ</sup>	2	166 (76)
	77	73 <sup>3</sup> / <sub>16</sub> (1859)							FRN773D13X <sup>Ⓜ</sup>	2	175 (80)
89	82 <sup>1</sup> / <sub>16</sub> (2100)							FRN782M13X <sup>Ⓜ</sup>	4	184 (84)	

#### Applications: Bunker C and #6 Fuel Oils

<b>8 W/in<sup>2</sup> Steel Flange 18-Steel</b> (1.3 W/cm <sup>2</sup> )	12.5	43 <sup>3</sup> / <sub>16</sub> (1099)			FRS743E12 <sup>Ⓜ</sup>	1			FRS743E13 <sup>Ⓜ</sup>	1	132 (60)
	16.5	51 <sup>1</sup> / <sub>16</sub> (1313)			FRS751M12	1			FRS751M13	1	137 (62)
	20	62 <sup>3</sup> / <sub>16</sub> (1580)			FRS762D12 <sup>Ⓜ</sup>	2			FRS762D13 <sup>Ⓜ</sup>	1	145 (66)
	24	70 <sup>1</sup> / <sub>16</sub> (1795)			FRS770M12	2			FRS770M13	1	151 (69)
	27	79 <sup>1</sup> / <sub>16</sub> (2024)			FRS779M12 <sup>Ⓜ</sup>	2			FRS779M13 <sup>Ⓜ</sup>	1	155 (71)
<b>8 W/in<sup>2</sup> Steel Flange 24-Steel</b> (1.3 W/cm <sup>2</sup> )	17	43 <sup>1</sup> / <sub>16</sub> (1110)			FRS743M12X <sup>Ⓜ</sup>	1			FRS743M13X <sup>Ⓜ</sup>	1	147 (67)
	22	51 <sup>1</sup> / <sub>16</sub> (1313)			FRS751M12X <sup>Ⓜ</sup>	2			FRS751M13X <sup>Ⓜ</sup>	1	154 (70)
	27	62 <sup>3</sup> / <sub>16</sub> (1580)			FRS762D12X <sup>Ⓜ</sup>	2			FRS762D13X <sup>Ⓜ</sup>	1	166 (76)
	32	70 <sup>1</sup> / <sub>16</sub> (1796)			FRS770M12X <sup>Ⓜ</sup>	2			FRS770M13X <sup>Ⓜ</sup>	1	175 (80)
	36	79 <sup>1</sup> / <sub>16</sub> (2024)			FRS779M12X <sup>Ⓜ</sup>	2			FRS779M13X <sup>Ⓜ</sup>	1	181 (82)

All flange immersion heaters are Assembly Stock unless otherwise noted.

Ⓜ Standard  
Ⓝ Must be operated 3-phase wye

#### Availability

**Stock:** Same day shipment

**Assembly Stock:** Five to seven working days

**Standard:** 10 working days, depending on size

■ Truck Shipment only

# Tubular and Process Assemblies

## Flange Immersion Heaters 10" 150 lb ANSI Flange—WATROD Element

WATROD Description	kW	Immersed B Dimension inch (mm)	Code No.				Est. Ship. Weight lbs (kg)
			240V~(ac) 3-Phase	No. of Circuits	480V~(ac) 3-Phase	No. of Circuits	

### Application: Process Water

48 W/in <sup>2</sup> ⑤	190	54¾ (1391)			FSN754N5②	9	240 (109)
Steel Flange	262	73¾ (1861)			FSN773E5	9	260 (118)
27-Incoloy® (7.5 W/cm <sup>2</sup> )							

### Applications: Forced Air and Gases, Caustic Solutions, Degreasing Solutions

23 W/in <sup>2</sup> ⑥	45	33¾ (845)	FSNA33E3②	3	FSNA33E5②	3	165 (75)
Steel Flange	60	43¾ (1111)	FSNA43N3②	3	FSNA43N5②	3	195 (89)
27-Incoloy® (3.6 W/cm <sup>2</sup> )	75	51¾ (1314)	FSNA51N3	9	FSNA51N5	3	230 (105)

### Applications: Lightweight Oils, Degreasing Solutions, Heat Transfer Oils

23 W/in <sup>2</sup>	45	33¾ (845)	FSS733E3②	3	FSS733E5②	3	165 (75)
Steel Flange	60	43¾ (1111)	FSS743N3②	3	FSS743N5②	3	195 (89)
27-Steel (3.6 W/cm <sup>2</sup> )	75	51¾ (1314)	FSS751N3	9	FSS751N5	3	230 (105)
	90	62¾ (1581)			FSS762E5②	3	250 (114)
	105	70¾ (1797)			FSS770N5	3	258 (117)
	120	78¾ (2000)			FSS778N5②	3	265 (121)

### Applications: Medium Weight Oils, Heat Transfer Oils, Liquid Paraffin

16 W/in <sup>2</sup> ③	63	54¾ (1391)			FSN754N13②	3	240 (109)
Steel Flange	75	63¾ (1619)			FSN763N13②	3	250 (114)
27-Incoloy® (2.5 W/cm <sup>2</sup> )	87	73¾ (1861)			FSN773E13	3	258 (117)

### Applications: Bunker C and #6 Fuel Oils

8 W/in <sup>2</sup> ③	25	51¾ (1314)	FSS751N12	3	FSS751N13	1	230 (105)
Steel Flange	30	62¾ (1581)	FSS762E12②	3	FSS762E13②	1	250 (114)
27-Steel	35	70¾ (1797)	FSS770N12	3	FSS770N13	1	258 (117)
(1.3 W/cm <sup>2</sup> )	40	78¾ (2000)	FSS778N12②	3	FSS778N13②	1	265 (121)

All flange immersion heaters are Assembly Stock unless otherwise noted.

#### Availability

**Stock:** Same day shipment

**Assembly Stock:** Five to seven working days

**Standard:** 10 working days, depending on size

■ Truck Shipment only

② Standard

③ Must be operated 3-phase wye.

⑤ 240V~(ac) 3-phase can be rewired wye to produce ½ more kW and watt density when operated at 480V~(ac) 3-phase.

⑥ Can be rewired wye to produce ½ of the original kW and watt density (3-phase only).

# Tubular and Process Assemblies

## Flange Immersion Heaters

### 12" 150 lb ANSI Flange—WATROD Element

WATROD Description	kW	Immersed B Dimension inch (mm)	Code No.				Est. Ship. Weight	
			240V~(ac) 3-Phase	No. of Circuits	480V~(ac) 3-Phase	No. of Circuits	lbs	(kg)

#### Application: Process Water

48 W/in <sup>2</sup>	250	54% (1387)			FTN754L5 <sup>②</sup>	6	280 (127)
Steel Flange	350	73% (1857)			FTN773C5	12	291 (132)
36-Incoloy <sup>®</sup> (7.5 W/cm <sup>2</sup> )							

#### Applications: Forced Air and Gases, Caustic Solutions, Degreasing Solutions

23 W/in <sup>2</sup>	60	33% (841)			FTNA33C5 <sup>②</sup>	3	205 (93)
Steel Flange	80	43% (1108)			FTNA43L5 <sup>②</sup>	3	240 (109)
36-Incoloy <sup>®</sup> (3.6 W/cm <sup>2</sup> )	100	51% (1311)			FTNA51L5	3	280 (127)

#### Applications: Lightweight Oils, Degreasing Solutions, Heat Transfer Oils

23 W/in <sup>2</sup>	60	33% (841)			FTS733C5 <sup>②</sup>	3	205 (93)
Steel Flange	80	43% (1108)			FTS743L5 <sup>②</sup>	3	240 (109)
36-Steel (3.6 W/cm <sup>2</sup> )	100	51% (1311)			FTS751L5	3	280 (127)
	120	62% (1578)			FTS762C5 <sup>②</sup>	3	285 (130)
	140	70% (1794)			FTS770L5	4	290 (132)
	160	78% (1997)			FTS778L5 <sup>②</sup>	4	300 (136)

#### Applications: Medium Weight Oils, Heat Transfer Oils, Liquid Paraffin

16 W/in <sup>2</sup> <sup>③</sup>	83	54% (1387)			FTN754L13 <sup>②</sup>	3	280 (127)
Steel Flange	117	73% (1857)			FTN773C13 <sup>②</sup>	3	291 (132)
36-Incoloy <sup>®</sup> (2.5 W/cm <sup>2</sup> )							

#### Applications: Bunker C and #6 Fuel Oils

8 W/in <sup>2</sup> <sup>③</sup>	34	51% (1311)	FTS751L12 <sup>②</sup>	2	FTS751L13	1	280 (127)
Steel Flange	40	62% (1578)	FTS762C12 <sup>②</sup>	2	FTS762C13 <sup>②</sup>	1	285 (130)
36-Steel (1.3 W/cm <sup>2</sup> )	47	70% (1794)	FTS770L12 <sup>②</sup>	3	FTS770L13	2	290 (132)
	54	78% (1997)	FTS778L12 <sup>②</sup>	3	FTS778L13 <sup>②</sup>	2	300 (136)

All flange immersion heaters are Assembly Stock unless otherwise noted.

② Standard  
③ Must be operated 3-phase wye.

#### Availability

**Stock:** Same day shipment

**Assembly Stock:** Five to seven working days

**Standard:** 10 working days, depending on size

■ Truck Shipment only

# Tubular and Process Assemblies

## Flange Immersion Heaters 14" 150 lb ANSI Flange—WATROD Element

WATROD Description	kW	Immersed B Dimension inch (mm)	Code No.				Est. Ship. Weight lbs (kg)
			240V~(ac) 3-Phase	No. of Circuits	480V~(ac) 3-Phase	No. of Circuits	

### Application: Process Water

48 W/in <sup>2</sup>	315	54½ (1384)			FWN754J5 <sup>Ⓢ</sup>	15	300 (136)
Steel Flange	375	63½ (1613)			FWN763J5 <sup>Ⓢ</sup>	15	310 (141)
45-Incoloy <sup>®</sup> (7.5 W/cm <sup>2</sup> )							

### Applications: Forced Air and Gases, Caustic Solutions, Degreasing Solutions

23 W/in <sup>2</sup>	75	33 (838)			FWNA33A5 <sup>Ⓢ</sup>	3	225 (102)
Steel Flange	100	43½ (1105)			FWNA43J5 <sup>Ⓢ</sup>	3	255 (116)
45-Incoloy <sup>®</sup> (3.6 W/cm <sup>2</sup> )	125	51½ (1308)			FWNA51J5	5	300 (136)

### Applications: Lightweight Oils, Degreasing Solutions, Heat Transfer Oils

23 W/in <sup>2</sup>	75	33 (838)			FWS733A5 <sup>Ⓢ</sup>	3	225 (102)
Steel Flange	100	43½ (1105)			FWS743J5 <sup>Ⓢ</sup>	3	255 (116)
45-Steel (3.6 W/cm <sup>2</sup> )	125	51½ (1308)			FWS751J5	5	300 (136)
	150	62 (1575)			FWS762A5 <sup>Ⓢ</sup>	5	310 (141)
	175	70½ (1791)			FWS770J5	5	318 (145)
	200	78½ (1994)			FWS778J5 <sup>Ⓢ</sup>	5	330 (150)

### Applications: Medium Weight Oils, Heat Transfer Oils, Liquid Paraffin

16 W/in <sup>2</sup> <sup>Ⓢ</sup>	105	54½ (1384)			FWN754J13 <sup>Ⓢ</sup>	3	300 (136)
Steel Flange	125	63½ (1613)			FWN763J13 <sup>Ⓢ</sup>	5	310 (141)
45-Incoloy <sup>®</sup> (2.5 W/cm <sup>2</sup> )							

### Applications: Bunker C and #6 Fuel Oils

8 W/in <sup>2</sup> <sup>Ⓢ</sup>	42	51½ (1308)	FWS751J12	3	FWS751J13	3	300 (136)
Steel Flange	50	62 (1575)	FWS762A12 <sup>Ⓢ</sup>	3	FWS762A13 <sup>Ⓢ</sup>	3	310 (141)
45-Steel	60	70½ (1791)	FWS770J12	3	FWS770J13	3	318 (144)
(1.3 W/cm <sup>2</sup> )	67	78½ (1994)	FWS778J12 <sup>Ⓢ</sup>	5	FWS778J13 <sup>Ⓢ</sup>	3	330 (150)

All flange immersion heaters are Assembly Stock unless otherwise noted.

<sup>Ⓢ</sup> Standard

<sup>Ⓢ</sup> Must be operated 3-phase wye.

#### Availability

**Stock:** Same day shipment

**Assembly Stock:** Five to seven working days

**Standard:** 10 working days, depending on size

■ Truck Shipment only

## Flange Immersion Heaters Build-a-Code

### Flange Immersion Heater Base Code Number<sup>①</sup>

(Includes general purpose enclosure without thermostat)

### Terminal Enclosure Type

- S** = General purpose (NEMA 1)
- W** = Moisture resistant (NEMA 4)
- E** = Explosion resistant (NEMA 7)
- E/W** = Explosion/moisture resistant (NEMA 7/4)

### Thermostat<sup>②</sup>

### Thermocouple<sup>③</sup>

- J** = Type J
- K** = Type K

- ① Flange immersion heaters are supplied with a standard, general purpose (NEMA 1) terminal enclosure. A thermostat will not fit the standard general purpose terminal enclosure on 2, 2½ and 3 inch flange sizes.
- ② Code numbers are shown on the Thermostat stock chart on [page 425](#). Check the temperature sensing bulb O.D. to be certain it will fit into the thermowell's I.D.
- ③ Specify Type J or K thermocouple. If overtemp thermocouple specify orientation horizontal, vertical up or vertical down.

### How to Order

To order a stock flange heater, please specify:

- Watlow code number
- Flange size and material
- Volts/watts
- Phase
- Options
- Quantity

If the flange immersion heater is to be configured with options, add the suffix letter(s) to the base flange heater code number, as indicated on the Build-a-Code chart.

If our stock units do not meet your application needs, Watlow will make-to-order.

For **made-to-order** units please specify:

- Application, including media heated, flow rate, pressure, and process operating temperatures
- Volts/watts
- Watt density
- Phase
- Number of circuits
- Number of heating elements
- Element diameter (WATROD only)
- Immersed ('B' dimension) length
- Flange size, rating and material
- No-heat section below the flange
- Terminal enclosure type
- Options
- Quantity

### Availability

**Stock:** Same day shipment

**Assembly Stock:** Five to seven working days

**Modified Stock<sup>③</sup>:** Five to seven working days

**Standard:** 10 working days

**Made-to-Order:** Five to seven weeks

Options, complexity and quantity may affect availability and lead times. Consult factory.

③ Stock or Assembly Stock units with catalog options.

## Tubular and Process Assemblies

### Quick Ship

On stock chart units:

- Same day on most heaters
- 10 working days on special voltages and/or wattages
- 15 working days on special element lengths

### Square Flange Immersion Heaters

Designed for use in boilers and industrial storage tanks, square flange immersion heaters offer an energy efficient solution to heating water, oils and degreasing solutions.

Consisting of WATROD or FIREBAR® elements brazed, staked, or welded to a four- or six-bolt flange, these heaters mount directly to a mating flange that is welded to a tank wall or nozzle.

Installation and maintenance is easy. Heater change-out is also simple ... unbolt the flange and replace it with another ... without extensive equipment downtime.

#### Performance Capabilities

- Watt densities to 100 W/in<sup>2</sup> (15.5 W/cm<sup>2</sup>)
- Wattages to 24kW
- Voltages to 480V~(ac)
- Incoloy® sheath temperatures to 1600°F (870°C)

#### Features and Benefits

- **2½, 3½ and 4½ inch square flanges** easily adapt to application needs.

#### Flange materials:

<b>WATROD</b>	Steel 304 stainless steel
<b>FIREBAR</b>	Steel Brass

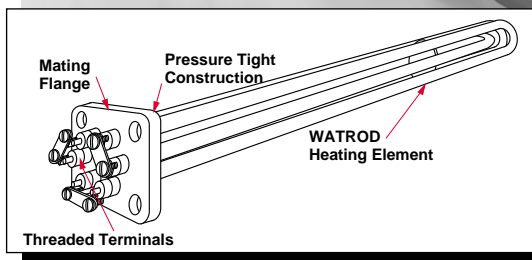

- **Asbestos-free gaskets** come wire-tied to each flange. Spare gaskets also available.
- **Epoxy or silicone resin seals**, rated to 250°F (120°C) or 390°F (200°C) respectively, protect elements against moisture and other contaminants.
- **WATROD hairpins are repressed (recompacted)** to maintain MgO density, dielectric strength, heat transfer and life.

- **UL® and CSA component recognition** under file numbers E52951 and 31388 respectively. See **pages 268 to 271** for details.

#### Applications

- Water
- Boiler equipment
- Vapor degreasers
- Fuel oils
- Heat transfer fluids
- Caustic solutions

#### Available on request:

- **Sheath materials** in copper, steel, 304 and 316 stainless steel and titanium
- **Flange materials** in titanium and 316 stainless steel

- **Flange sizes** to meet specific application needs
- **External finishes** such as passivation, belt polishing and glass beading

- **Other voltage and wattage ratings**  
Consult your Watlow representative for details.

# Tubular and Process Assemblies

F.O.B.: Hannibal, Missouri

## Square Flange Immersion Heaters

### Application Hints

- Determine recommended sheath materials and watt densities by using the **Element and Assembly Selection Guide** on pages 262 to 263. If wattage is not known, consult your Watlow representative.
- Extend the element's no-heat section completely in the fluid at all times to prevent premature

heater failure. See the accompanying illustration for proper placement of the no-heat section.

- Mount WATROD and FIREBAR square flange heaters horizontally and low in the tank, but above sludge level.
- Periodically remove heaters to inspect and clean the elements.

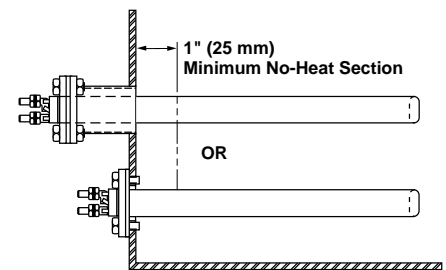

- Keep terminations clean, dry and tight.
- Minimize problems associated with low liquid level conditions by using a low liquid level sensor.

Heater Dimension	Inch	(mm)
A	1 ½	(38)
C	2 ½	(64)
D	2 ½	(64)
E	1	(25)
H	1 ½	(38)

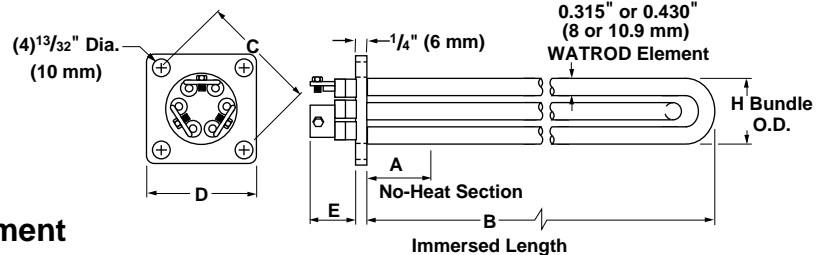

### 2 ½" Square Flange—WATROD Element

WATROD Description	kW	Immersed B Dimension inch (mm)	Code No.				Est. Ship.	
			240V~(ac) 1-Phase	240V~(ac) 3-Phase	480V~(ac) 1-Phase	480V~(ac) 3-Phase	Weight lbs (kg)	

#### Applications: Clean and Potable Water

100 W/in <sup>2</sup> Steel Flange 3-Incoloy® (15.5 W/cm <sup>2</sup> )	8.0	11 ¾ (298)	FHN11N10②	FHN11N3②	FHN11N11②	FHN11N5	18 (9)
---	-----	------------	-----------	----------	-----------	---------	--------

#### Applications: Forced Air and Gases, Caustic Solutions, Degreasing Solutions

30 W/in <sup>2</sup> 304 SS Flange 3-Incoloy® (4.7 W/cm <sup>2</sup> )	3.0	18 ½ (470)	FHN18J10①	FHN18J3	FHN18J11②	FHN18J5②	19 (9)
	3.75	23 ¾ (586)	FHN23B10①	FHN23B3①	FHN23B11②	FHN23B5②	20 (9)
25 W/in <sup>2</sup> 304 SS Flange 3-Incoloy® (3.9 W/cm <sup>2</sup> )	1.5	12 (305)	FHN12A10①	FHN12A3	FHN12A11②	FHN12A5②	18 (8)

#### Applications: Bunker C and #6 Fuel Oils

10 W/in <sup>2</sup> 304 SS Flange 3-Incoloy® (1.6 W/cm <sup>2</sup> )	1.0	18 ½ (470)		FHN18J12①		FHN18J13②	19 (9)
	1.25	23 ¾ (586)		FHN23B12①		FHN23B13②	20 (9)
8 W/in <sup>2</sup> 304 SS Flange 3-Incoloy® (1.3 W/cm <sup>2</sup> )	0.5	12 (305)		FHN12A12①		FHN12A13②	18 (8)

All square flange heaters are Stock unless otherwise noted.

① Assembly Stock  
② Standard

#### Availability

**Stock:** Same day shipment

**Assembly Stock:** Five to seven working days

**Standard:** Six weeks

# Tubular and Process Assemblies

## Square Flange Immersion Heaters

Heater Dimension	Inch	(mm)
A	1½	(38)
C	2½	(64)
D	2½	(64)
E	1¼	(44)
H	1⅝	(33)

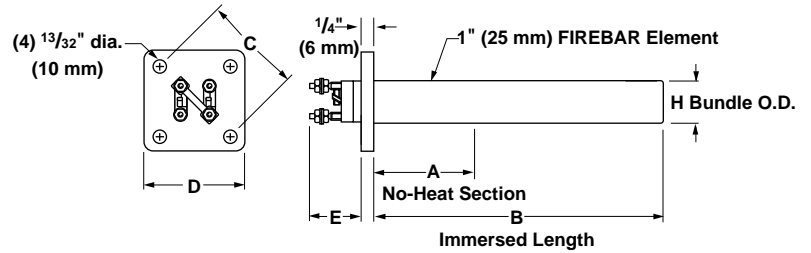

### 2½" Square Flange—FIREBAR Element

FIREBAR Description	kW	Immersed B Dimension inch (mm)	Code No.					Est. Ship. Weight lbs (kg)
			208V~(ac) 3-Phase	240V~(ac) 1-Phase	240V~(ac) 3-Phase	480V~(ac) 1-Phase	480V~(ac) 3-Phase	

#### Applications: Clean and Potable Water

100 W/in <sup>2</sup> Steel Flange 1-Incoloy® (15.5 W/cm <sup>2</sup> )	5	11½ (292)	FHNFA11J26N②	FHNFA11J10N①	FHNFA11J3N①	FHNFA11J11N②	FHNFA11J5N②	5 (3)
	8	20¾ (527)	FHNFA20N26N②	FHNFA20N10N①	FHNFA20N3N①	FHNFA20N11N②	FHNFA20N5N①	7 (4)
	10	24¾ (619)	FHNFA24G26N②	FHNFA24G10N①	FHNFA24G3N②	FHNFA24G11N②	FHNFA24G5N①	8 (4)
	15	33⅝ (862)	FHNFA33S26N②		FHNFA33S3N②	FHNFA33S11N②	FHNFA33S5N①	9 (5)
80 W/in <sup>2</sup> Steel Flange 1-Incoloy® (12.4 W/cm <sup>2</sup> )	16	22¾ (575)	FHNFB22L26J②	FHNFB22L10J②	FHNFB22L3J②	FHNFB22L11J②	FHNFB22L5J②	10 (5)

Heater Dimension	Inch	(mm)
A	1⅞	(40)
C	3⅞	(90)
D	3⅞	(74)
E	1⅞	(40)
H	2½	(54)

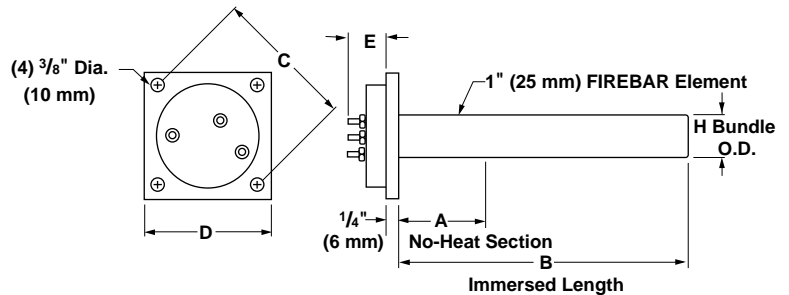

### 3⅞" Square Flange—FIREBAR Element

FIREBAR Description	kW	Immersed B Dimension Inch (mm)	Code No.			Est. Ship. Weight lbs (kg)
			208V~(ac) 3-Phase	240V~(ac) 3-Phase	480V~(ac) 3-Phase	

#### Applications: Clean and Potable Water

80 W/in <sup>2</sup> Brass Flange 1-Incoloy® (12.4 W/cm <sup>2</sup> )	18	24½ (622)	FENFB24J26J①	FENFB24J3J②	FENFB24J5J①	12 (6)

#### Applications: Process Water, Ethylene Glycol (50%)

40 W/in <sup>2</sup> Brass Flange 1-Incoloy® (6.2 W/cm <sup>2</sup> )	9	24½ (622)	FENFB24J26K②	FENFB24J3K②	FENFB24J5K②	12 (6)
--	---	-----------	--------------	-------------	-------------	--------

#### Availability

**Stock:** Same day shipment

**Assembly Stock:** Five to seven working days

**Standard:** Six weeks

① Stock

② Standard

# Tubular and Process Assemblies

## Square Flange Immersion Heaters

Heater Dimension	Inch	(mm)
A	1	(25)
C	3 1/8	(97)
D	4 1/2	(114)
E	2 1/4	(57)
H	3 1/2	(82)

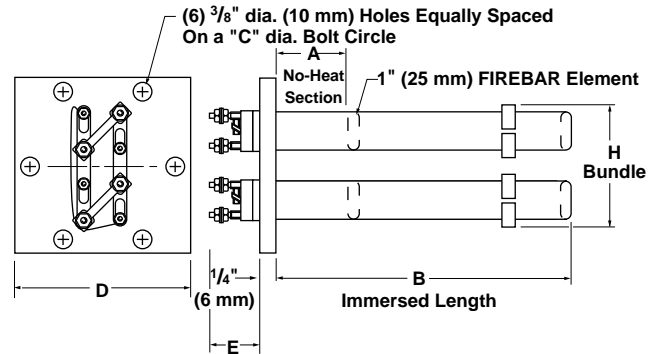

### 4 1/2" Square Flange—FIREBAR Element

FIREBAR Description	kW	Immersed B Dimension Inch (mm)	Code No.			Est. Ship. Weight lbs (kg)
			208V~(ac) 3-Phase	240V~(ac) 3-Phase	480V~(ac) 3-Phase	

#### Applications: Clean and Potable Water

100 W/in <sup>2</sup> Steel Flange 2-Incoloy® (15.5 W/cm <sup>2</sup> )	18	10 1/2 (267)	FGNFB10J26N②	FGNFB10J3N②	FGNFB10J5N①	16 (8)
70 W/in <sup>2</sup> Steel Flange 2-Incoloy® (10.9 W/cm <sup>2</sup> )	12	10 1/2 (267)	FGNFB10J26P①	FGNFB10J3P②	FGNFB10J5P①	16 (8)

#### Availability

**Stock:** Same day shipment

**Assembly Stock:** Five to seven working days

**Standard:** Six weeks

① Stock

② Standard

#### How to Order

To order a stock unit, please specify:

- Watlow code number
- Flange size and material
- Volts/watts
- Phase
- Quantity

If our stock units do not meet your application needs, Watlow can provide a made-to-order unit.

For **made-to-order** units, please specify:

- Application
- Volts/watts
- Phase
- Flange size, dimensions and material
- Sheath material and diameter
- Number of elements
- No-heat section below the flange
- Immersed ('B' dimension) length
- Maximum bundle diameter (H) or clearance hole size
- Bolt pattern, if not standard
- Options
- Quantity

© Stock or Assembly Stock units with catalog options.

#### Availability

**Stock:** Same day shipment

**Assembly Stock:** Five to seven working days

**Modified Stock**®: Five to seven working days

**Standard:** Three weeks

**Made-to-Order:** Four to six weeks

Options, complexity and quantity may affect availability and lead times. Consult factory.

# Tubular and Process Assemblies

**Quick Ship**

On stock chart units:

- Five to seven working days on all Assembly Stock heaters
- 10 working days on special voltages and/or wattages
- 15 working days on special element lengths

## Circulation Heaters

Circulation heaters provide a ready-made means to install electric heating with a minimal amount of time and labor. This is accomplished by combining heating elements, vessel, insulation, terminal enclosure, mounting brackets and inlet and outlet connections into a complete assembly.

Made from NPT screw plug or ANSI flange heater assemblies mated with a pressure vessel (tank), circulation heaters are designed to heat forced-circulation air, gases or liquids. Ideal for either in-line or side-arm operations, these assemblies direct fluids past FIREBAR® or WATROD heating elements, to deliver fast response and even heat distribution.

Watlow can meet virtually all your circulation heater assembly needs with made-to-order units. Made-to-order units can be made from a wide range of heating element sheath materials, wattages, vessel sizes and materials, pressure ratings, terminal enclosures and controls.

### Performance Capabilities

- Watt densities to 120 W/in<sup>2</sup> (18.6 W/cm<sup>2</sup>)
- Wattages to one megawatt
- UL® and CSA component recognition to 480V~(ac) and 600V~(ac) respectively
- Ratings to 600 lb pressure class
- Incoloy® sheath temperatures to 1600°F (870°C)
- Passivated 316 stainless steel sheath temperatures to 1200°F (650°C)
- Steel sheath temperatures to 750°F (400°C)
- Copper sheath temperatures to 350°F (175°C)

UL® is a registered trademark of Underwriter's Laboratories, Inc.  
Incoloy® is a registered trademark of Special Metals Corporation.

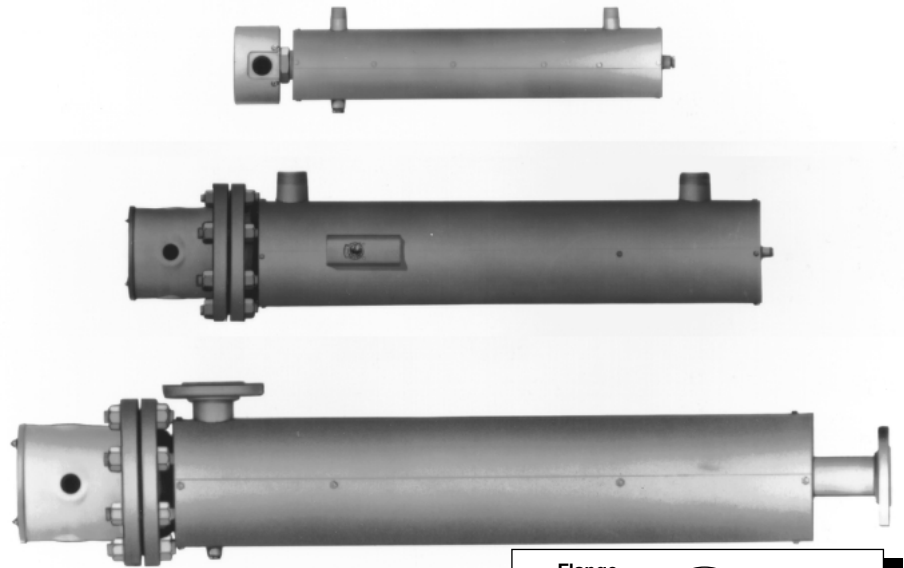

### Features and Benefits

- **Standard screw plugs and flanges** feature a wide selection of WATROD and FIREBAR elements to meet specific application requirements.

Type	Sizes (inch)
NPT Screw Plugs	1¼, 2½
ANSI flanges	3, 4, 5, 6, 8, 10, 12, 14

- **Flange ratings meet recognized agency standards.** ANSI B16.5 Class 150 on:
  - Four or six inch FIREBAR element flanges
  - Three to 14 inch WATROD element flanges
- **FIREBAR assemblies** pack more wattage in a smaller heater bundle—replaces larger flanges with round tubular elements, with a smaller package.
- **Compacted MgO insulation filled elements** maximize dielectric strength, heat transfer and life.
- **One inch (25 mm) thermal insulation**, rated to 750°F (400°C), reduces heat loss from the vessel.

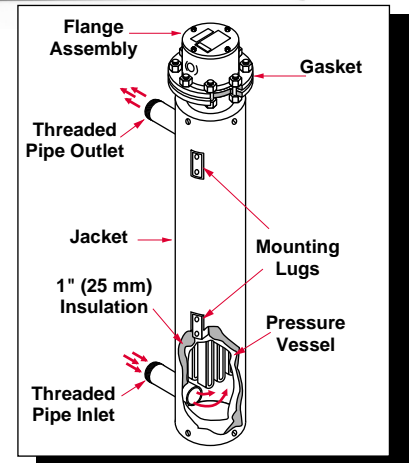

- **Heavy-gauge steel jacket (shroud)** protects thermal insulation and heating vessel. Comes with protective primer coating.
- **All catalog units rated to ANSI pressure Class 150.** Pressure vessels (tanks) are either carbon or 316 stainless steel.
- **NPT or ANSI Class 150 nozzle connections** make installation easy. Inlet and outlet nozzle connections are:
  - Threaded MNPT on eight inch and smaller tanks
  - Class 150 flanged connections on 10 inch and larger tanks

Circulation Heaters

# Tubular and Process Assemblies

## Circulation Heaters

### Features and Benefits

- **Mounting lugs** are welded onto the tank wall of all 2½ inch NPT and larger units. Lugs are flush with outer insulation jacket and provide mounting support.
- **Flange mounting holes** straddle centerline to comply with industry standards.
- **Standard, general purpose (NEMA 1) terminal enclosures** offer easy access to terminal wiring.
- **UL® and CSA component recognition** under file numbers E52951 and 31388 respectively. See **pages 268 to 271** for details.
- **Branch circuits** are subdivided by National Electric Code (NEC) requirements to a maximum of 48 amps per circuit.

### Applications

- Water:
  - Deionized
  - Demineralized
  - Clean
  - Potable
  - Process
- Industrial water rinse tanks
- Hydraulic oil, crude, asphalt
- Lubricating oils at API specified watt densities
- Heat transfer oil
- Paraffin
- Caustic cleaners
- Nitrogen, hydrogen and other air/gas systems
- Superheating steam

### Options

#### Terminal Enclosures

General purpose (NEMA 1) terminal enclosures, without thermostats, are supplied on all Watlow circulation heaters. Moisture and explosion resistant ratings are available to meet specific application needs. For screw plug terminal enclosures,

refer to **pages 322 to 324**. For flange terminal enclosures, refer to **pages 340 to 341**.

#### Stand-off Terminal Enclosures

Stand-off terminal enclosures help protect terminal enclosures against excessive temperatures. For details, refer to **page 340**.

#### CSA Certified Enclosures

To meet agency recognition requirements, CSA certified moisture and/or explosion resistant terminal enclosures are available. Consult your Watlow representative for details.

#### Thermostats

To provide process temperature control, Watlow offers optional single and double pole thermostats.

Thermostats are typically mounted in the terminal enclosure. Optional side mounting on vessel also available.

See **Screw Plug Immersion Heaters, page 324**, and **Flange Immersion Heaters, on page 342** for details.

#### Thermocouples

To sense process or element sheath temperature, ASTM Type J or K thermocouples are available.

See **Screw Plug Immersion Heaters, page 325** and **Flange Immersion Heaters, on page 342** for details.

### Process Thermocouple in Nozzle

(Must specify which nozzle)

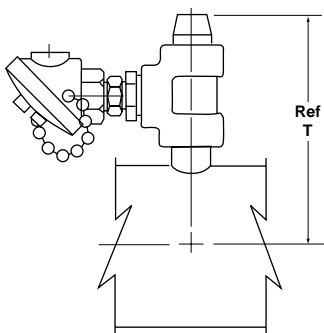

Ref. Tank Size	Ref. Nozzle Size	Dimension "A"
1 ¼	¾ NPT	8 ⅜
2 ½	1 NPT	8 ⅜
3	1 NPT	8 ⅜
4	1 ½ NPT	10 ⅜
5	2 NPT	11 ⅜
6	2 ½ NPT	13 ⅜
8	2 ½ NPT	14 ⅜

For 10 inch and larger tanks consult factory for dimension.

# Tubular and Process Assemblies

## Circulation Heaters

### Options

Continued

### Branch Circuits

Branch circuits are subdivided by National Electrical Code (NEC) requirements to a maximum of

48 amps per circuit. Consult factory for circuit requirements other than those listed in the stock charts.

### Wattages and Voltages

Watlow routinely supplies circulation heaters with 120 to 480V~(ac) as well as wattages from 500 watts to one megawatt. If required, Watlow will configure circulation heaters

with voltages and wattages outside these parameters.

For more information on special voltage and wattage configurations, consult your Watlow representative.

### Sheath Materials

The following sheath materials are available on WATROD and FIREBAR heating elements:

### Standard Sheath Materials

<b>WATROD</b>	Incoloy® 316 stainless steel Steel Copper
<b>FIREBAR</b>	Incoloy®

### Made-to-Order Sheath Materials

<b>WATROD</b>	304 stainless steel Monel®
<b>FIREBAR</b>	304 stainless steel

### Exotic Sheath Materials

Consult your Watlow representative for details and availability.

### Baffles

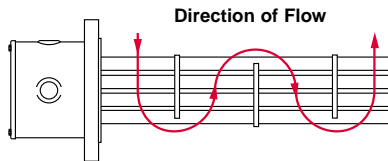

Baffles mounted on the heating element bundle enhance and/or modify liquid or gas flow for better heat transfer.

For critical sheath temperature and low flow conditions, baffles may be required.

Consult your Watlow representative for details.

### Pressure Vessels

All standard pressure vessel (tank) materials are rated to 150 lb and made from:

- Carbon steel
- 316 stainless steel

All catalog pressure vessels (tanks) are steel unless otherwise noted.

316 stainless steel pressure vessels (tanks) are passivated on all wetted surfaces. Available from Assembly Stock on 2½ inch NPT and four or six inch ANSI flange circulation heaters.

Made-to-order units can be made in a variety of materials, flange sizes and pressure classes.

To order, specify **pressure vessel (tank) size, material and pressure class**.

ANSI ratings to 600 lb are available for high-pressure applications. For pressure class ratings above 600 lb, as well as other vessel materials, consult Watlow Process Systems in Troy, Missouri.

### Passivated Finish

For critical applications, passivation will remove free iron from all wetted surfaces.

Consult factory for details.

Monel® is a registered trademark of Special Metals Corporation.

# Tubular and Process Assemblies

## Circulation Heaters

### Options

Continued

#### Gaskets

Rubber, asbestos-free and spiral wound gaskets are available for all heater flange, and inlet and outlet flange sizes.

Watlow recommends ordering spares in case replacement becomes necessary.

To order, specify **gasket type, flange size/rating** and **process operating temperature**.

For details on gasket materials and temperature ratings, see **page 343**.

#### Inlet and Outlet Nozzle Connections

All inlet and outlet materials are compatible with the pressure vessel material and pressure class rating.

Vessel sizes from 1¼ to eight inches are typically configured with MNPT (Male National Pipe Thread) nozzles. Optional NPT and flange sizes can be supplied to mate with existing piping.

10 inch and larger vessels are supplied with Class 150 inlet and outlet flanges. Optional Class 300 or Class 600 can be provided to mate with existing piping.

To order, specify **type, size** and **pressure class** rating for both inlet and outlet nozzle/flange connections.

#### High Temperature Thermal Insulation

To further minimize heat loss, the pressure vessel's standard one inch thermal insulation wrap may be replaced with thicker or higher temperature insulation. For more information, consult your Watlow representative.

To order, specify **insulation thickness, standard** or **high temperature insulation** and **temperature rating**.

Vessels may be supplied with a primer coating without insulation.

To order, specify **no insulation**.

#### Protective Steel Jacket (Shroud)

To protect circulation heaters from weather or wash-down conditions, fully welded (weatherproof) or partially welded (standard) outer protective steel jackets are available. Standard steel, or made-to-order 304 or 316 stainless steel

can be supplied. Jacket diameter is dependent upon thermal insulation thickness.

To order, specify **protective steel jacket, material type** and **weatherproof**, if desired.

#### Support Saddles

To mate with an existing installation, customized support saddle(s) and/or mounting lugs are available.

To order, specify **mounting lugs** or **support saddles** and supply a dimensional drawing.

# Tubular and Process Assemblies

## Circulation Heaters

### Maximum Velocities

The rate at which a gas or liquid flows through inlet and outlet pipes is critical to maintaining the desired output temperature. Pressure drop through the circulation heater must be considered to properly size blowers or pumps. The *Maximum Velocity to Avoid Excessive Pressure Drop* chart gives recommended maximum velocities, in feet per second and meters per second of gas or liquid being heated and nominal pipe size.

### Maximum Velocity to Avoid Excessive Pressure Drop

Fluid	Nominal Pipe Size inch	Maximum Velocity	
		ft/sec	(m/sec)
Gases	All	200	(61.0)
Liquid	4 and smaller	10	(3.0)
Liquid	6-8	15	(5.0)
Liquid	10-12	19	(6.0)
Liquid	14-16	21	(6.4)
Liquid	18-20	23	(7.0)
Liquid	24	24	(7.3)

### Vessel Orientation Guidelines

Correctly orienting the heating vessel assures lower terminal enclosure temperatures and element immersion. Detailed instructions on vessel orientation are contained in the *Installation and Maintenance Instructions* that accompanies all circulation heaters. The following are guidelines for vessel orientation in liquid and gas heating applications.

#### Liquids

Orient circulation heater:

- Horizontally with inlet and outlet pipes pointing up
- Vertically with the terminal enclosure up and the inlet pipe on the bottom

These orientations ensure the heating elements will be immersed at all times and help prevent premature failure.

#### Air or Gases

Orient circulation heater:

- Horizontally with the inlet nozzle closest to the terminal enclosure.
- Vertically with terminal enclosure at the bottom of the tank. Use the nozzle nearest the bottom as the inlet connection.

If installation constraints do not allow mounting in accordance with these guidelines, consult your Watlow representative.

### Application Hints

- Select the recommended heating element sheath material and watt density for the substance being heated. Use the **Supplemental Applications Chart** on **pages 263 to 266**. If unable to determine the correct heating element type and material, consult your Watlow representative.
- Assure selecting proper vessel by considering the pressure or flow rate, process temperature and corrosiveness of the media being heated. If assistance with vessel selection is required, consult your Watlow representative.
- For maintenance/replacement procedures, retain an area twice the circulation heater's overall length to permit easy removal and inspection of screw plug or flange heater assemblies.
- Choose a FIREBAR assembly when you require:
  - A smaller package
  - More kilowatts or lower watt density in an equally sized WATROD circulation tank.
- Minimize problems associated with low flow or low liquid level conditions with a low liquid level sensor and/or sheath high-limit control.
- Ensure wiring integrity by making sure terminal enclosure temperature does not exceed 400°F (205°C).
- Protect against electrical shock by properly grounding the unit per NEC requirements.
- One or more circulation heaters may be connected in series to achieve the desired total kilowatt or temperature output.

# Tubular and Process Assemblies

F.O.B.: Hannibal, Missouri

## Circulation Heaters

### Replacement Heater Assemblies

To help assure minimum process downtime, it's advisable to order and keep on hand a replacement flange or screw plug heater assembly.

Spare and/or replacement screw plug or flange heaters can be ordered by simply providing the

complete circulation heater code number and specifying "replacement heater only."

### 1 1/4" NPT

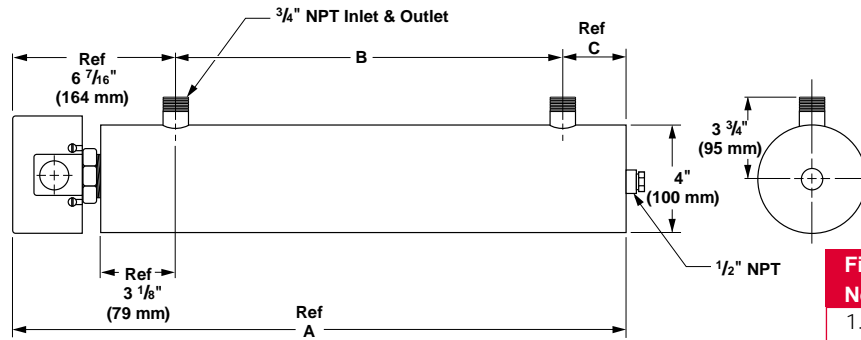

Fig. No.	A Dimension in (mm)	B Dimension in (mm)	C Dimension in (mm)
1.1	24 5/8 (625)	15 (381)	3 1/8 (79)
1.2	32 5/8 (829)	23 (584)	3 (76)
1.3	42 5/8 (1083)	32 (813)	4 (102)
1.4	63 5/8 (1616)	53 (1346)	4 (102)

### 1 1/4" NPT Screw Plug—WATROD Element

WATROD Description	kW	Fig. No.	Code No.		Est. Ship. Weight lbs (kg)
			120/240V~(ac) 1-Phase	240V~(ac) 1-Phase	

#### Application: Clean Water

60 W/in <sup>2</sup> ④	3.0	1.1	CBEC15A6		23 (11)
Steel Tank	4.0	1.1		CBEC19A10	29 (14)
2-Copper	5.0	1.2		CBEC23J10	29 (14)
(9.3 W/cm <sup>2</sup> )	6.0	1.2		CBEC27J10	31 (14)

#### Applications: Forced Air and Gases, Caustic Solutions, Degreasing Solutions

23 W/in <sup>2</sup> ④	1.0	1.1	CBEN13G6		21 (10)
Steel Tank	1.5	1.1	CBEN19A6		29 (14)
2-Incoloy®	2.0	1.2	CBEN24G6		29 (14)
(3.6 W/cm <sup>2</sup> )					

#### Applications: Lightweight Oils, Degreasing Solutions, Heat Transfer Oils

23 W/in <sup>2</sup> ④	1.5	1.1	CBES19G6		29 (14)
Steel Tank	2.0	1.2	CBES25G6		29 (14)
2-Steel					
(3.6 W/cm <sup>2</sup> )					

All circulation heaters are Assembly Stock unless otherwise noted.

④ Wired for higher voltage.

#### Availability

**Assembly Stock:** Five to seven working days

**Standard:** 10 working days

# Tubular and Process Assemblies

## Circulation Heaters

### 1 1/4" NPT Screw Plug—FIREBAR Element

FIREBAR Description	kW	Fig. No.	Code No.				Est. Ship.	
			240V~(ac) 1-Phase	240V~(ac) 3-Phase	480V~(ac) 1-Phase	480V~(ac) 3-Phase	Weight lbs (kg)	

#### Applications: Clean and Potable Water

<b>90 W/in<sup>2</sup>®</b> Steel Tank 1-Incoloy® (14 W/cm <sup>2</sup> )	1.5	1.1	CBDNF7R10 <sup>②⑦</sup>		CBDNF7R11 <sup>②⑦</sup>		26 (12)
	3.0	1.1	CBDNF11G10 <sup>②⑦</sup>		CBDNF11G11 <sup>②</sup>		26 (12)
	5.0	1.1		CBDNF16G3		CBDNF16G5	26 (12)
	6.5	1.2		CBDNF19G3		CBDNF19G5	30 (14)
	8.5	1.2		CBDNF24L3		CBDNF24L5	31 (14)
	10.5	1.3		CBDNF29R3		CBDNF29R5	43 (20)
	12.75	1.3		CBDNF34R3		CBDNF34R5	44 (20)
	17.0	1.4		CBDNF45G3		CBDNF45G5	69 (32)
	21.5	1.4				CBDNF55R5	71 (33)

#### Applications: Process Water, Ethylene Glycol (50%)

<b>45 W/in<sup>2</sup>®</b> Steel Tank 1-Incoloy® (7 W/cm <sup>2</sup> )	2.0	1.1		CBDNF13A27			25 (12)
	2.5	1.1		CBDNF15J27			26 (12)
	3.0	1.2		CBDNF18A27			30 (14)
	4.0	1.2		CBDNF22J27		CBDNF22J28	31 (14)
	5.0	1.3		CBDNF27J27		CBDNF27J28	43 (20)
	6.0	1.3		CBDNF32J27		CBDNF32J28	44 (20)
	8.0	1.4		CBDNF42A27		CBDNF42A28	69 (32)
	10.0	1.4		CBDNF51J27		CBDNF51J28	71 (33)

#### Applications: Cooking Oils, Ethylene Glycol (100%)

<b>30 W/in<sup>2</sup>®</b> Steel Tank 1-Incoloy® (4.7 W/cm <sup>2</sup> )	1.7	1.1		CBDNF16G12		CBDNF16G13	26 (12)
	2.2	1.2		CBDNF19G12		CBDNF19G13	30 (14)
	2.8	1.2		CBDNF24L12		CBDNF24L13	31 (14)
	3.5	1.3		CBDNF29R12		CBDNF29R13	43 (20)
	4.25	1.3		CBDNF34R12		CBDNF34R13	44 (20)
	5.7	1.4		CBDNF45G12		CBDNF45G13	69 (32)
	7.2	1.4		CBDNF55R12		CBDNF55R13	71 (33)

#### Applications: Heat Transfer Oils, Lubrication Oils, Mineral Oil, Degreasing Solutions

<b>23 W/in<sup>2</sup>®</b> Steel Tank 1-Incoloy® (3.6 W/cm <sup>2</sup> )	1.25	1.1		CBDNF16G20			26 (12)
	1.65	1.2		CBDNF19G20			30 (14)
	2.15	1.2		CBDNF24L20		CBDNF24L19	31 (14)
	2.65	1.3		CBDNF29R20		CBDNF29R19	43 (20)
	3.20	1.3		CBDNF34R20		CBDNF34R19	44 (20)
	4.25	1.4		CBDNF45G20		CBDNF45G19	69 (32)
	5.40	1.4		CBDNF55R20		CBDNF55R19	71 (33)

CONTINUED 

All circulation heaters are Assembly Stock unless otherwise noted.

**Availability**

**Assembly Stock:** Five to seven working days

**Standard:** 10 working days

 Truck Shipment only

- ② Standard
- ③ Must be operated 3-phase wye.
- ⑦ Available in 1-phase only.
- ⑧ Can be wired 1-phase.

# Tubular and Process Assemblies

## Circulation Heaters

### 1 1/4" NPT Screw Plug—FIREBAR Element

FIREBAR Description	kW	Fig. No.	Code No.				Est. Ship.	
			240V~(ac) 1-Phase	240V~(ac) 3-Phase	480V~(ac) 1-Phase	480V~(ac) 3-Phase	Weight lbs	(kg)

**Applications: Medium Weight Oils, Heat Transfer Oils, Lube Oils, Liquid Paraffin**

15 W/in <sup>2</sup> ⓐ	0.67	1.1		CBDNF13A29			25 (12)
Steel Tank	0.83	1.1		CBDNF15J29			26 (12)
1-Incoloy®	1.00	1.2		CBDNF18A29			30 (14)
(2.3 W/cm <sup>2</sup> )	1.33	1.2		CBDNF22J29		CBDNF22J30	31 (14)
	1.67	1.3		CBDNF27J29		CBDNF27J30	43 (20)
	2.00	1.3		CBDNF32J29		CBDNF32J30	44 (20)
	2.67	1.4		CBDNF42A29		CBDNF42A30	69 (32)
	3.30	1.4		CBDNF51J29		CBDNF51J30	71 (33)

**Applications: Bunker C and #6 Fuel Oils, Asphalt**

8 W/in <sup>2</sup> ⓐ	0.43	1.1		CBDNF16G22			26 (12)
Steel Tank	0.55	1.2		CBDNF19G22			30 (14)
1-Incoloy®	0.70	1.2		CBDNF24L22		CBDNF24L21	31 (14)
(1.3 W/cm <sup>2</sup> )	0.88	1.3		CBDNF29R22		CBDNF29R21	43 (20)
	1.08	1.3		CBDNF34R22		CBDNF34R21	44 (20)
	1.40	1.4		CBDNF45G22		CBDNF45G21	69 (31)
	1.80	1.4		CBDNF55R22		CBDNF55R21	71 (32)

All circulation heaters are Assembly Stock unless otherwise noted.

Truck Shipment only

ⓐ Must be operated 3-phase wye only.

#### Availability

**Assembly Stock:** Five to seven working days

**Standard:** 10 working days

### 2 1/2" NPT

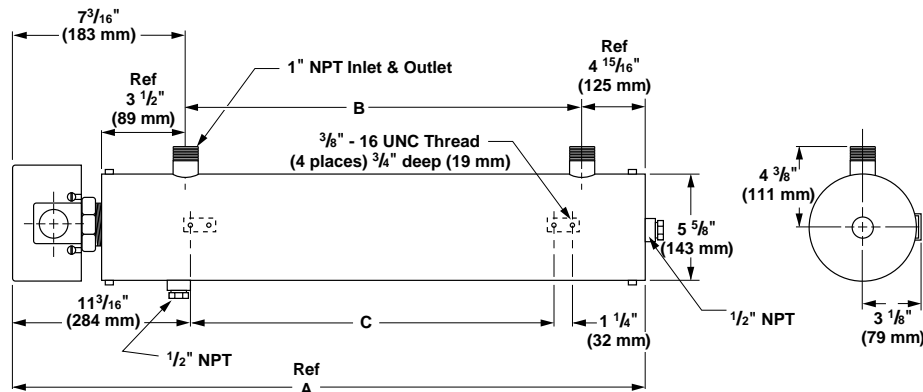

### 2 1/2" NPT Screw Plug

Fig. No.	A Dimension in (mm)	B Dimension in (mm)	C Dimension in (mm)
2.1	34 1/16 (881)	22 1/2 (572)	16 1/2 (419)
2.2	44 1/16 (1135)	32 1/2 (1129)	26 1/2 (673)
2.3	57 3/16 (1453)	45 (1143)	39 (991)
2.4	63 1/16 (1618)	51 1/2 (1308)	46 1/2 (1181)
2.5	34 1/16 (881)	22 1/2 (572)	16 1/2 (419)
2.6	44 1/16 (1135)	32 1/2 (1129)	26 1/2 (673)
2.7	57 3/16 (1453)	45 (1143)	39 (991)

# Tubular and Process Assemblies

## Circulation Heaters

### 2½" NPT Screw Plug—WATROD Element

WATROD Description	kW	Fig. No.	Code No.		Est. Ship. Weight	
			240V~(ac) 3-Phase	480V~(ac) 3-Phase	lbs	(kg)

#### Application: Clean Water

60 W/in <sup>2</sup> Steel Tank	6.0	2.5	CBLC714L3	CBLC714L5	24	(11)
	7.5	2.5	CBLC717L3	CBLC717L5	24	(11)
3-Copper	9.0	2.5	CBLC720L3	CBLC720L5	26	(12)
(9.3 W/cm <sup>2</sup> )	12.0	2.6	CBLC726C3	CBLC726C5	27	(13)
	15.0	2.6	CBLC731L3	CBLC731L5	29	(14)
	18.0	2.7	CBLC737C3	CBLC737C5	30	(14)

#### Application: Deionized Water, Demineralized Water

60 W/in <sup>2</sup> 316 SS Tank	6.0	2.5	CBLR714L3	CBLR714L5	24	(11)
	7.5	2.5	CBLR717L3	CBLR717L5	24	(11)
3-316 SS	9.0	2.5	CBLR720L3	CBLR720L5	26	(12)
(9.3 W/cm <sup>2</sup> )	12.0	2.6	CBLR726C3	CBLR726C5	27	(13)
Passivated	15.0	2.6	CBLR731L3	CBLR731L5	29	(14)
	18.0	2.7	CBLR737C3	CBLR737C5	30	(14)

#### Application: Process Water

48 W/in <sup>2</sup> Steel Tank	6.0	2.5	CBLN717G3	CBLN717G5	24	(11)
	7.5	2.5	CBLN719R3	CBLN719R5	26	(12)
3-Incoloy®	9.0	2.5	CBLN724R3	CBLN724R5	27	(13)
(7.5 W/cm <sup>2</sup> )	12.0	2.6	CBLN732G3	CBLN732G5	29	(14)
	15.0	2.7	CBLN739R3	CBLN739R5	31	(14)
	18.0	2.7	CBLN747G3	CBLN747G5	32	(15)

#### Applications: Forced Air and Gases, Caustic Solutions, Degreasing Solutions

23 W/in <sup>2</sup> Steel Tank	3.0	2.5	CBLNA17G3	CBLNA17G5	24	(11)
	4.5	2.6	CBLNA24R3	CBLNA24R5	27	(13)
3-Incoloy®	6.0	2.6	CBLNA32G3	CBLNA32G5	29	(14)
(3.6 W/cm <sup>2</sup> )	7.5	2.7	CBLNA39R3	CBLNA39R5	31	(14)
	9.0	2.7	CBLNA47G3	CBLNA47G5	32	(15)

#### Applications: Lightweight Oils, Degreasing Solutions, Heat Transfer Oils

23 W/in <sup>2</sup> Steel Tank	3.0	2.5	CBSL717E3	CBSL717E5	24	(11)
	4.5	2.5	CBSL724N3	CBSL724N5	27	(13)
3-Steel	6.0	2.6	CBSL732E3	CBSL732E5	29	(14)
(3.6 W/cm <sup>2</sup> )	7.5	2.7	CBSL739N3	CBSL739N5	31	(14)
	9.0	2.7	CBSL747E3	CBSL747E5	32	(15)

#### Applications: Medium Weight Oils, Heat Transfer Oils, Lube Oils, Liquid Paraffin

16 W/in <sup>2</sup> Steel Tank	2.0	2.5	CBLN717G12	CBLN717G13	24	(11)
	2.5	2.5	CBLN719R12	CBLN719R13	26	(12)
3-Incoloy®	3.0	2.5	CBLN724R12	CBLN724R13	27	(13)
(2.5 W/cm <sup>2</sup> )	4.0	2.6	CBLN732G12	CBLN732G13	29	(14)
	5.0	2.7	CBLN739R12	CBLN739R13	31	(14)
	6.0	2.7	CBLN747G12	CBLN747G13	32	(15)

#### Applications: Bunker C and #6 Fuel Oils

8 W/in <sup>2</sup> Steel Tank	2.0	2.6	CBSL732E12	CBSL732E13	29	(14)
	3.0	2.7	CBSL747E12	CBSL747E13	32	(15)
3-Steel						
(1.3 W/cm <sup>2</sup> )						

All circulation heaters are Assembly Stock unless otherwise noted.

**Availability**

**Assembly Stock:** Five to seven working days

**Standard:** 10 working days

- ③ Must be operated 3-phase wye only.
- ⑤ 240V~(ac) can be wired wye and operated at 480V~(ac) 3-phase to produce ½ more kW and watt density.
- ⑥ Can be wired wye to produce ½ of the original kW and watt density (3-phase only).

# Tubular and Process Assemblies

## Circulation Heaters

### 2½" NPT Screw Plug—FIREBAR Element

FIREBAR Description	kW	Fig. No.	Code No.		Est. Ship.	
			240V~(ac) 3-Phase	480V~(ac) 3-Phase	Weight lbs	(kg)

#### Applications: Clean and Potable Water

90 W/in <sup>2</sup> ®	15.0	2.1	CBLNF15C3	CBLNF15C5	22	(10)
Steel Tank	20.0	2.1	CBLNF18C3	CBLNF18C5 <sup>③</sup>	23	(11)
3-Incoloy®	25.0	2.1		CBLNF23C5	31	(14)
(14 W/cm <sup>2</sup> )	32.0	2.2		CBLNF28L5	34	(16)
	38.0	2.2		CBLNF33L5	35	(16)

#### Applications: Process Water, Ethylene Glycol (50%)

45 W/in <sup>2</sup> ®	6.0	2.1	CBLNF12A27		21	(10)
Steel Tank	7.5	2.1	CBLNF14J27		22	(10)
3-Incoloy®	9.0	2.1	CBLNF17A27		23	(11)
(7 W/cm <sup>2</sup> )	12.0	2.1	CBLNF21J27	CBLNF21J28	31	(14)
	15.0	2.2	CBLNF26J27	CBLNF26J28	34	(16)
	18.0	2.2	CBLNF31J27	CBLNF31J28	35	(16)
	24.0	2.3		CBLNF41A28	44	(20)
	30.0	2.4		CBLNF50J28	52	(24)

#### Applications: Cooking Oils, Ethylene Glycol (100%)

30 W/in <sup>2</sup> ®	5.0	2.1	CBLNF15C12	CBLNF15C13	22	(10)
Steel Tank	6.5	2.1	CBLNF18C12	CBLNF18C13	23	(11)
3-Incoloy®	8.5	2.1	CBLNF23C12	CBLNF23C13	31	(14)
(4.7 W/cm <sup>2</sup> )	10.5	2.2	CBLNF28L12	CBLNF28L13	34	(16)
	12.8	2.2	CBLNF33L12	CBLNF33L13	35	(16)
	17.0	2.3	CBLNF44C12	CBLNF44C13	44	(20)
	21.5	2.4		CBLNF54L13	52	(24)

#### Applications: Heat Transfer Oils, Mineral Oil, Degreasing Solutions

23 W/in <sup>2</sup> ®	3.8	2.1	CBLNF15C20		22	(10)
Steel Tank	4.9	2.1	CBLNF18C20		23	(11)
3-Incoloy®	6.4	2.1	CBLNF23C20	CBLNF23C19	31	(14)
(3.6 W/cm <sup>2</sup> )	7.9	2.2	CBLNF28L20	CBLNF28L19	34	(16)
	9.6	2.2	CBLNF33L20	CBLNF33L19	35	(16)
	12.8	2.3	CBLNF44C20	CBLNF44C19	44	(20)
	16.1	2.4	CBLNF54L20	CBLNF54L19	52	(24)

#### Applications: Medium Weight Oils, Heat Transfer Oils, Lube Oils, Liquid Paraffin

15 W/in <sup>2</sup> ®	2.0	2.1	CBLNF12A29		21	(10)
Steel Tank	2.5	2.1	CBLNF14J29		22	(10)
3-Incoloy®	3.0	2.1	CBLNF17A29		23	(11)
(2.3 W/cm <sup>2</sup> )	4.0	2.1	CBLNF21J29	CBLNF21J30	31	(14)
	5.0	2.2	CBLNF26J29	CBLNF26J30	34	(16)
	6.0	2.2	CBLNF31J29	CBLNF31J30	35	(16)
	8.0	2.3	CBLNF41A29	CBLNF41A30	44	(20)
	10.0	2.4	CBLNF50J29	CBLNF50J30	52	(24)

#### Applications: Bunker C and #6 Fuel Oils, Asphalt

8 W/in <sup>2</sup> ®	1.25	2.1	CBLNF15C22		22	(10)
Steel Tank	1.63	2.1	CBLNF18C22		23	(10)
3-Incoloy®	2.13	2.1	CBLNF23C22	CBLNF23C21	31	(14)
(1.3 W/cm <sup>2</sup> )	2.63	2.2	CBLNF28L22	CBLNF28L21	34	(15)
	3.19	2.2	CBLNF33L22	CBLNF33L21	35	(16)
	4.25	2.3	CBLNF44C22	CBLNF44C21	44	(20)
	5.38	2.4	CBLNF54L22	CBLNF54L21	52	(24)

All circulation heaters are Assembly Stock unless otherwise noted.

#### Availability

**Assembly Stock:** Five to seven working days

**Standard:** 10 working days

**Note:** Assembly Stock may be shipped same day if ordered before 11:00 am CST.

③ Must be operated 3-phase wye only.

④ Can be wired 1-phase.

# Tubular and Process Assemblies

## Circulation Heaters

### 3" Flange

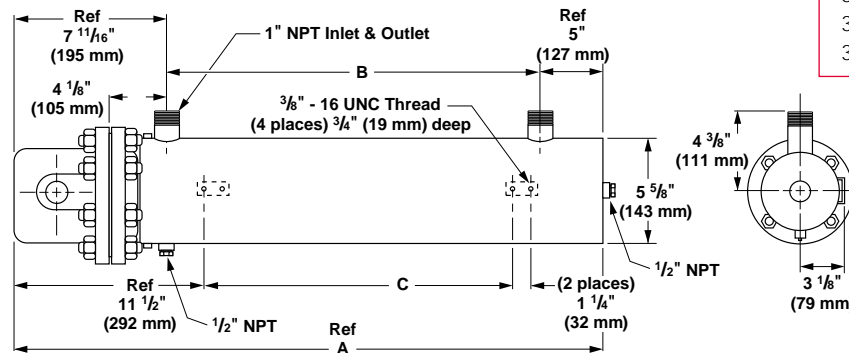

Fig. No.	A Dimension in (mm)	B Dimension in (mm)	C Dimension in (mm)
3.1	35 5/16 (894)	22 1/2 (573)	16 1/2 (419)
3.2	45 3/16 (1148)	32 1/2 (826)	26 1/2 (673)
3.3	57 1/16 (1465)	45 (1143)	39 (991)

### 3" 150 lb ANSI Flange—WATROD Element

WATROD Description	kW	Fig. No.	Code No.				Est. Ship. Weight lbs (kg)
			240V~(ac) 1-Phase	240V~(ac) 3-Phase	480V~(ac) 1-Phase	480V~(ac) 3-Phase	

#### Application: Clean Water

60 W/in <sup>2</sup>	6.0	3.1	CFMC715J10	CFMC715J3	CFMC715J11	CFMC715J5	66 (30)
Steel Tank	9.0	3.1	CFMC721J10	CFMC721J3	CFMC721J11	CFMC721J5	70 (32)
3-Copper	12.0	3.2		CFMC727A3	CFMC727A11	CFMC727A5	80 (37)
(9.3 W/cm <sup>2</sup> )	15.0	3.2		CFMC732J3	CFMC732J11	CFMC732J5	96 (44)
	18.0	3.3		CFMC738A3	CFMC738A11	CFMC738A5	98 (45)

#### Application: Process Water

48 W/in <sup>2</sup> Ⓢ	6.0	3.1	CFMN718A10	CFMN718A3	CFMN718A11	CFMN718A5	68 (31)
Steel Tank	7.5	3.1	CFMN720J10	CFMN720J3	CFMN720J11	CFMN720J5	70 (32)
3-Incoloy®	9.0	3.2	CFMN725J10	CFMN725J3	CFMN725J11	CFMN725J5	78 (36)
(7.5 W/cm <sup>2</sup> )	12.0	3.2		CFMN733A3	CFMN733A11	CFMN733A5	96 (44)
	15.0	3.3		CFMN740J3	CFMN740J11	CFMN740J5	100 (46)
	18.0	3.3		CFMN748A3	CFMN748A11	CFMN748A5	107 (49)

#### Applications: Forced Air and Gases, Caustic Solutions, Degreasing Solutions

23 W/in <sup>2</sup> ⓈⓈ	3.0	3.1	CFMNA18A10	CFMNA18A3	CFMNA18A11	CFMNA18A5	68 (31)
Steel Tank	4.5	3.2	CFMNA25J10	CFMNA25J3	CFMNA25J11	CFMNA25J5	78 (36)
3-Incoloy®	6.0	3.2	CFMNA33A10	CFMNA33A3	CFMNA33A11	CFMNA33A5	96 (44)
(3.6 W/cm <sup>2</sup> )	7.5	3.3	CFMNA40J10	CFMNA40J3	CFMNA40J11	CFMNA40J5	100 (46)
	9.0	3.3	CFMNA48A10	CFMNA48A3	CFMNA48A11	CFMNA48A5	107 (49)

CONTINUED

All circulation heaters are Assembly Stock unless otherwise noted.

#### Availability

**Assembly Stock:** Five to seven working days

**Standard:** 10 working days

Truck Shipment only

- Ⓢ 240V~(ac) can be wired wye and operated at 480V~(ac) 3-phase to produce 1/2 more kW and watt density.
- Ⓢ Can be wired wye to produce 1/2 of the original kW and watt density (3-phase only).

# Tubular and Process Assemblies

## Circulation Heaters

### 3" 150 lb ANSI Flange—WATROD Element

WATROD Description	kW	Fig. No.	Code No.				Est. Ship. Weight	
			240V~(ac) 1-Phase	240V~(ac) 3-Phase	480V~(ac) 1-Phase	480V~(ac) 3-Phase	lbs	(kg)

#### Applications: Lightweight Oils, Degreasing Solutions, Heat Transfer Oils

<b>23 W/in<sup>2</sup></b>	3.0	3.1	<b>CFMS718A10</b>	<b>CFMS718A3</b>	<b>CFMS718A11</b>	<b>CFMS718A5</b>	68 (31)
<b>Steel Tank</b>	4.5	3.1	<b>CFMS725J10</b>	<b>CFMS725J3</b>	<b>CFMS725J11</b>	<b>CFMS725J5</b>	78 (36)
<b>3-Steel</b>	6.0	3.2	<b>CFMS733A10</b>	<b>CFMS733A3</b>	<b>CFMS733A11</b>	<b>CFMS733A5</b>	96 (44)
(3.6 W/cm <sup>2</sup> )	7.5	3.3	<b>CFMS740J10</b>	<b>CFMS740J3</b>	<b>CFMS740J11</b>	<b>CFMS740J5</b>	100 (46)
	9.0	3.3	<b>CFMS748A10</b>	<b>CFMS748A3</b>	<b>CFMS748A11</b>	<b>CFMS748A5</b>	107 (49)

#### Applications: Medium Weight Oils, Heat Transfer Oils, Lube Oils, Liquid Paraffin

<b>16 W/in<sup>2</sup>ⓐ</b>	2.0	3.1		<b>CFMN718A12</b>		<b>CFMN718A13</b>	68 (31)
<b>Steel Tank</b>	2.5	3.1		<b>CFMN720J12</b>		<b>CFMN720J13</b>	70 (32)
<b>3-Incoloy®</b>	3.0	3.2		<b>CFMN725J12</b>		<b>CFMN725J13</b>	78 (36)
(2.6 W/cm <sup>2</sup> )	4.0	3.2		<b>CFMN733A12</b>		<b>CFMN733A13</b>	96 (44)
	5.0	3.3		<b>CFMN740J12</b>		<b>CFMN740J13</b>	100 (46)
	6.0	3.3		<b>CFMN748A12</b>		<b>CFMN748A13</b>	107 (49)

#### Applications: Bunker C and #6 Fuel Oils

<b>8 W/in<sup>2</sup>ⓐ</b>	2.0	3.2		<b>CFMS733A12</b>		<b>CFMS733A13</b>	96 (44)
<b>Steel Tank</b>	3.0	3.3		<b>CFMS748A12</b>		<b>CFMS748A13</b>	107 (49)
<b>3-Steel</b>							
(1.3 W/cm <sup>2</sup> )							

All circulation heaters are Assembly Stock unless otherwise noted.

ⓐ Must be operated 3-phase wye only.

#### Availability

**Assembly Stock:** Five to seven working days

**Standard:** 10 working days

Truck Shipment only

# Tubular and Process Assemblies

## Circulation Heaters

### 4" Flange

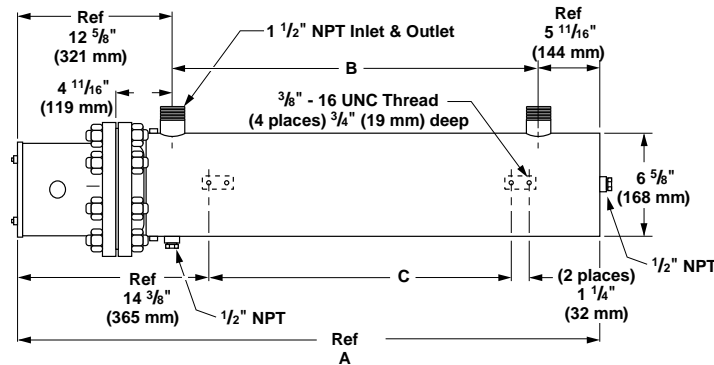
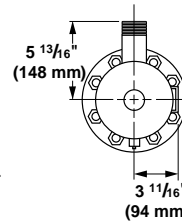

Fig. No.	A Dimension in (mm)	B Dimension in (mm)	C Dimension in (mm)
4.1	38 <sup>15</sup> / <sub>16</sub> (989)	20 <sup>1</sup> / <sub>2</sub> (521)	17 (432)
4.2	49 <sup>1</sup> / <sub>16</sub> (1256)	31 (787)	27 <sup>1</sup> / <sub>2</sub> (699)
4.3	70 <sup>1</sup> / <sub>16</sub> (1789)	52 (1321)	48 <sup>1</sup> / <sub>2</sub> (1232)
4.4	91 <sup>1</sup> / <sub>16</sub> (2326)	73 (1854)	66 (1676)



### 4" 150 lb ANSI Flange—WATROD Element

WATROD Description	kW	Fig. No.	Code No.								Est. Ship. Weight	
			240V~(ac) 1-Phase	No. of Circuits	240V~(ac) 3-Phase	No. of Circuits	480V~(ac) 1-Phase	No. of Circuits	480V~(ac) 3-Phase	No. of Circuits	lbs (kg)	

#### Application: Clean Water

60 W/in <sup>2</sup> Steel Tank	12	4.1	CFOC715J10	2	CFOC715J3	1	CFOC715J11	1	CFOC715J5	1	124 (57)
	18	4.1	CFOC721J10	2	CFOC721J3	1	CFOC721J11	1	CFOC721J5	1	127 (58)
6-Copper (9.3 W/cm <sup>2</sup> )	24	4.2	CFOC727A10	2	CFOC727A3	2	CFOC727A11	1	CFOC727A5	1	160 (73)
	30	4.2			CFOC732J3	2	CFOC732J11	2	CFOC732J5	1	163 (74)
	36	4.3			CFOC738A3	2	CFOC738A11	2	CFOC738A5	1	229 (104)
	50	4.3							CFOC751A5 <sup>②</sup>	2	234 (107)
	60	4.4							CFOC760J5 <sup>②</sup>	2	297 (135)

#### Application: Deionized Water, Demineralized Water

60 W/in <sup>2</sup> Steel Tank	12	4.1	CFOR716A10	1	CFOR716A3	1	CFOR716A11	1	CFOR716A5	1	124 (57)
316 SS Tank	18	4.1	CFOR722A10	2	CFOR722A3	1	CFOR722A11	1	CFOR722A5	1	127 (58)
	24	4.2	CFOR727J10	2	CFOR727J3	2	CFOR727J11	1	CFOR727J5	1	160 (73)
6-316 SS (9.3 W/cm <sup>2</sup> )	30	4.2			CFOR733A3	2	CFOR733A11	2	CFOR733A5	1	163 (74)
	36	4.3			CFOR738J3	2	CFOR738J11	2	CFOR738J5	1	229 (104)
Passivated	50	4.3							CFOR751J5	2	234 (106)
	60	4.4							CFOR761A5	2	297 (135)

#### Application: Process Water

48 W/in <sup>2</sup> Steel Tank	9	4.1	CFON713J10	1	CFON713J3	1	CFON713J11	1	CFON713J5	1	122 (56)
	12	4.1	CFON718A10	2	CFON718A3	1	CFON718A11	1	CFON718A5	1	125 (57)
6-Incoloy <sup>®</sup> (7.5 W/cm <sup>2</sup> )	15	4.1	CFON720J10	2	CFON720J3	1	CFON720J11	2	CFON720J5	1	127 (58)
	18	4.1	CFON725J10	2	CFON725J3	1	CFON725J11	1	CFON725J5	1	160 (73)
	24	4.2	CFON733A10	2	CFON733A3	2	CFON733A11	1	CFON733A5	1	163 (74)
	30	4.3			CFON740J3	2	CFON740J11	2	CFON740J5	1	229 (104)
	36	4.3			CFON748A3	2	CFON748A11	2	CFON748A5	1	234 (107)

CONTINUED

All circulation heaters are Assembly Stock unless otherwise noted.

② Standard

#### Availability

**Assembly Stock:** Five to seven working days

**Standard:** 10 working days

Truck Shipment only

# Tubular and Process Assemblies

## Circulation Heaters

### 4" 150 lb ANSI Flange—WATROD Element

WATROD Description	kW	Fig. No.	Code No.								Est. Ship.	
			240V~(ac) 1-Phase	No. of Circuits	240V~(ac) 3-Phase	No. of Circuits	480V~(ac) 1-Phase	No. of Circuits	480V~(ac) 3-Phase	No. of Circuits	Weight lbs	(kg)

#### Applications: Forced Air and Gases, Caustic Solutions, Degreasing Solutions

<b>23 W/in<sup>2</sup></b> <b>Steel Tank</b> <b>6-Incoloy®</b> (3.6 W/cm <sup>2</sup> )	6	4.1	<b>CFONA18A10</b>	1	<b>CFONA18A3</b>	1	<b>CFONA18A11</b>	1	<b>CFONA18A5</b>	1	125 (57)
	9	4.1	<b>CFONA25J10</b>	1	<b>CFONA25J3</b>	1	<b>CFONA25J11</b>	1	<b>CFONA25J5</b>	1	160 (73)
	12	4.2	<b>CFONA33A10</b>	2	<b>CFONA33A3</b>	1	<b>CFONA33A11</b>	1	<b>CFONA33A5</b>	1	163 (74)
	15	4.3	<b>CFONA40J10</b>	2	<b>CFONA40J3</b>	1	<b>CFONA40J11</b>	1	<b>CFONA40J5</b>	1	229 (104)
	18	4.3	<b>CFONA48A10</b>	2	<b>CFONA48A3</b>	1	<b>CFONA48A11</b>	1	<b>CFONA48A5</b>	1	234 (107)
	25	4.4			<b>CFONA64J3</b>	2	<b>CFONA64J11</b>	2	<b>CFONA64J5</b>	1	298 (136)
	30	4.4			<b>CFONA77A3</b>	2	<b>CFONA77A11</b>	2	<b>CFONA77A5</b>	1	306 (139)

#### Applications: Lightweight Oils, Degreasing Solutions, Heat Transfer Oils

<b>23 W/in<sup>2</sup></b> <b>Steel Tank</b> <b>6-Steel</b> (3.6 W/cm <sup>2</sup> )	6	4.1	<b>CFOS718A10</b>	1	<b>CFOS718A3</b>	1	<b>CFOS718A11</b>	1	<b>CFOS718A5</b>	1	125 (57)
	9	4.1	<b>CFOS725J10</b>	1	<b>CFOS725J3</b>	1	<b>CFOS725J11</b>	1	<b>CFOS725J5</b>	1	160 (73)
	12	4.2	<b>CFOS733A10</b>	2	<b>CFOS733A3</b>	1	<b>CFOS733A11</b>	1	<b>CFOS733A5</b>	1	163 (74)
	15	4.3	<b>CFOS740J10</b>	2	<b>CFOS740J3</b>	1	<b>CFOS740J11</b>	1	<b>CFOS740J5</b>	1	229 (104)
	18	4.3	<b>CFOS748A10</b>	2	<b>CFOS748A3</b>	1	<b>CFOS748A11</b>	1	<b>CFOS748A5</b>	1	234 (107)
	25	4.4			<b>CFOS764J3</b>	2	<b>CFOS764J11</b>	2	<b>CFOS764J5</b>	1	298 (136)
	30	4.4			<b>CFOS777A3</b>	2	<b>CFOS777A11</b>	2	<b>CFOS777A5</b>	1	306 (139)

#### Applications: Medium Weight Oils, Heat Transfer Oils, Liquid Paraffin

<b>16 W/in<sup>2</sup></b> <b>Steel Tank</b> <b>6-Incoloy®</b> (2.6 W/cm <sup>2</sup> )	3	4.1			<b>CFON713J12</b>	1			<b>CFON713J13</b>	1	122 (56)
	4	4.1			<b>CFON718A12</b>	1			<b>CFON718A13</b>	1	125 (57)
	5	4.1			<b>CFON720J12</b>	1			<b>CFON720J13</b>	1	127 (58)
	6	4.1			<b>CFON725J12</b>	1			<b>CFON725J13</b>	1	160 (73)
	8	4.2			<b>CFON733A12</b>	1			<b>CFON733A13</b>	1	163 (74)
	10	4.3			<b>CFON740J12</b>	2			<b>CFON740J13</b>	1	229 (104)
	12	4.3			<b>CFON748A12</b>	1			<b>CFON748A13</b>	1	234 (107)

#### Applications: Bunker C and #6 Fuel Oils

<b>8 W/in<sup>2</sup></b> <b>Steel Tank</b> <b>6-Steel</b> (1.3 W/cm <sup>2</sup> )	5	4.3			<b>CFOS740J12</b>	1			<b>CFOS740J13</b>	1	229 (104)
	6	4.3			<b>CFOS748A12</b>	1			<b>CFOS748A13</b>	1	234 (106)
	8	4.4			<b>CFOS764J12</b>	1			<b>CFOS764J13</b>	1	298 (135)
	10	4.4			<b>CFOS777A12</b>	1			<b>CFOS777A13</b>	1	306 (139)

All circulation heaters are Assembly Stock unless otherwise noted.

#### Availability

**Assembly Stock:** Five to seven working days

**Standard:** 10 working days

Truck Shipment only

③ Must be operated 3-phase wye only.

⑤ 240V~(ac) can be wired wye and operated at 480V~(ac) 3-phase to produce ½ more kW and watt density.

⑥ Can be wired wye to produce ½ of the original kW and watt density (3-phase only).

# Tubular and Process Assemblies

## Circulation Heaters

### 4" 150 lb ANSI Flange—FIREBAR Element

FIREBAR Description	kW	Fig. No.	Code No.				Est. Ship. Weight lbs (kg)
			240V~(ac) 3-Phase	No. of Circuits	480V~(ac) 3-Phase	No. of Circuits	

#### Applications: Process Water, Ethylene Glycol (50%)

45 W/in <sup>2</sup> Steel Tank 6-Incoloy® (7 W/cm <sup>2</sup> )	12.0	4.1	CFONF13G27	1			125 (57)
	15.0	4.1	CFONF16A27	1			128 (58)
	18.0	4.1	CFONF18G27	1			130 (59)
	24.0	4.1	CFONF22R27	2	CFONF22R28	1	133 (61)
	30.0	4.2	CFONF27R27	2	CFONF27R28	1	168 (77)
	36.0	4.2	CFONF32R27	2	CFONF32R28	1	170 (78)
	48.0	4.3			CFONF42G28	2	236 (107)
	60.0	4.3			CFONF51R28	2	240 (109)

#### Applications: Cooking Oils, Ethylene Glycol (100%)

30 W/in <sup>2</sup> Steel Tank 6-Incoloy® (4.7 W/cm <sup>2</sup> )	10.0	4.1	CFONF16J12	1	CFONF16J13	1	128 (58)
	13.0	4.1	CFONF19J12	1	CFONF19J13	1	130 (59)
	17.0	4.1	CFONF24J12	1	CFONF24J13	1	133 (61)
	21.0	4.2	CFONF30A12	2	CFONF30A13	1	168 (77)
	25.5	4.2	CFONF35A12	2	CFONF35A13	1	170 (78)
	34.0	4.3	CFONF45J12	2	CFONF45J13	1	236 (107)
	43.0	4.3			CFONF56A13	2	240 (109)

#### Applications: Heat Transfer Oils, Mineral Oils, Degreasing Solutions

23 W/in <sup>2</sup> ④ Steel Tank 6-Incoloy® (3.6 W/cm <sup>2</sup> )	7.5	4.1	CFONF16J20	1			128 (58)
	10.0	4.1	CFONF19J20	1			130 (59)
	12.8	4.1	CFONF24J20	1	CFONF24J19	1	133 (61)
	15.8	4.2	CFONF30A20	1	CFONF30A19	1	168 (77)
	19.0	4.2	CFONF35A20	1	CFONF35A19	1	170 (78)
	25.0	4.3	CFONF45J20	2	CFONF45J19	1	236 (107)
	32.3	4.3	CFONF56A20	2	CFONF56A19	1	240 (109)

#### Applications: Medium Weight Oils, Heat Transfer Oils, Lube Oils, Liquid Paraffin

15 W/in <sup>2</sup> ③ Steel Tank 6-Incoloy® (2.3 W/cm <sup>2</sup> )	4.0	4.1	CFONF13G29	1			125 (57)
	5.0	4.1	CFONF16A29	1			128 (58)
	6.0	4.1	CFONF18G29	1			130 (59)
	8.0	4.1	CFONF22R29	1	CFONF22R30	1	133 (61)
	10.0	4.2	CFONF27R29	1	CFONF27R30	1	168 (77)
	12.0	4.2	CFONF32R29	1	CFONF32R30	1	170 (78)
	16.0	4.3	CFONF42G29	1	CFONF42G30	1	236 (107)
	20.0	4.3	CFONF51R29	1	CFONF51R30	1	240 (109)

#### Applications: Bunker C and #6 Fuel Oils, Asphalt

8 W/in <sup>2</sup> ③ Steel Tank 6-Incoloy® (1.3 W/cm <sup>2</sup> )	2.5	4.1	CFONF16J22	1			128 (58)
	3.25	4.1	CFONF19J22	1			130 (59)
	4.25	4.1	CFONF24J22	1	CFONF24J21	1	133 (61)
	5.25	4.2	CFONF30A22	1	CFONF30A21	1	168 (77)
	6.38	4.2	CFONF35A22	1	CFONF35A21	1	170 (77)
	8.5	4.3	CFONF45J22	1	CFONF45J21	1	236 (107)
	10.75	4.3	CFONF56A22	1	CFONF56A21	1	240 (109)

All circulation heaters are Assembly Stock unless otherwise noted.

③ Must be operated 3-phase wye only.

④ Wired for higher voltage.

#### Availability

**Assembly Stock:** Five to seven working days

**Standard:** 10 working days

■ Truck Shipment only

# Tubular and Process Assemblies

## Circulation Heaters

### 5" Flange

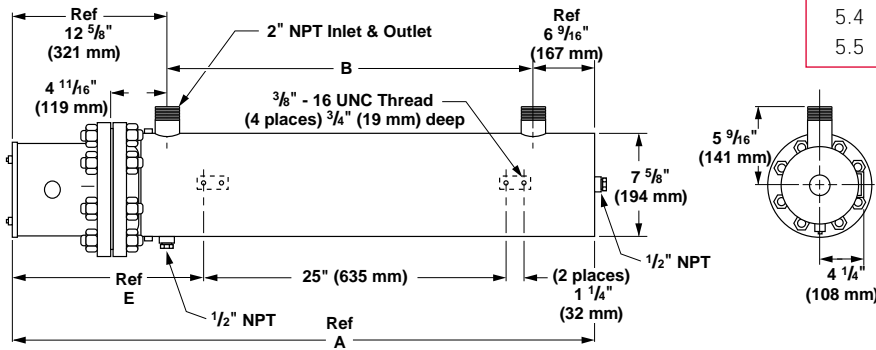

Fig. No.	A Dimension in (mm)	B Dimension in (mm)	E Dimension in (mm)
5.1	49 <sup>3</sup> / <sub>16</sub> (1249)	30 (762)	14 <sup>7</sup> / <sub>16</sub> (378)
5.2	56 <sup>3</sup> / <sub>16</sub> (1427)	37 (940)	18 <sup>3</sup> / <sub>16</sub> (471)
5.3	67 <sup>1</sup> / <sub>16</sub> (1719)	48 <sup>7</sup> / <sub>16</sub> (1232)	24 <sup>15</sup> / <sub>16</sub> (633)
5.4	81 <sup>1</sup> / <sub>16</sub> (2059)	61 <sup>7</sup> / <sub>16</sub> (1572)	30 <sup>7</sup> / <sub>16</sub> (784)
5.5	94 <sup>1</sup> / <sub>16</sub> (2389)	74 <sup>7</sup> / <sub>16</sub> (1902)	37 <sup>15</sup> / <sub>16</sub> (964)

### 5" 150 lb ANSI Flange—WATROD Element

WATROD Description	kW	Fig. No.	Code No.								Est. Ship. Weight	
			240V~(ac) 1-Phase	No. of Circuits	240V~(ac) 3-Phase	No. of Circuits	480V~(ac) 1-Phase	No. of Circuits	480V~(ac) 3-Phase	No. of Circuits	lbs	(kg)

#### Application: Clean Water

60 W/in <sup>2</sup> Steel Tank	24	5.1	CFNC727A10	3	CFNC727A3	2	CFNC727A11	3	CFNC727A5	1	140 (64)	
	30	5.1			CFNC732J3	2	CFNC732J11	2	CFNC732J5	1	142 (65)	
	6-Copper (9.3 W/cm <sup>2</sup> )	36			5.2	CFNC738A3	2	CFNC738A11	2	CFNC738A5	1	160 (73)
		50			5.3					CFNC751A5	2	180 (82)
	60	5.4					CFNC760J5 <sup>②</sup>	2	190 (87)			
60 W/in <sup>2</sup> Steel Tank	36	5.1			CFNC727A3X	3	CFNC727A11X	3	CFNC727A5X	1	145 (66)	
	45	5.1			CFNC732J3X	3	CFNC732J11X	3	CFNC732J5X	3	147 (67)	
	9-Copper (9.3 W/cm <sup>2</sup> )	54	5.2			CFNC738A3X	3	CFNC738A11X	3	CFNC738A5X	3	166 (76)
		75	5.3						CFNC751A5X	3	188 (86)	
	90	5.4						CFNC760J5X <sup>②</sup>	3	200 (91)		

#### Application: Process Water

48 W/in <sup>2</sup> <sup>⑤</sup> Steel Tank	24	5.1	CFNN733A10	3	CFNN733A3	2	CFNN733A11	3	CFNN733A5	1	145 (66)
	30	5.2			CFNN740J3	2	CFNN740J11	2	CFNN740J5	1	167 (76)
	6-Incoloy <sup>®</sup> (7.5 W/cm <sup>2</sup> )	36			5.3	CFNN748A3	2	CFNN748A11	2	CFNN748A5	1
48 W/in <sup>2</sup> Steel Tank	36	5.1			CFNN733A3X	3	CFNN733A11X	3	CFNN733A5X	1	150 (68)
	45	5.2			CFNN740J3X	3	CFNN740J11X	3	CFNN740J5X	3	173 (79)
	9-Incoloy <sup>®</sup> (7.5 W/cm <sup>2</sup> )	54	5.3			CFNN748A3X	3	CFNN748A11X	3	CFNN748A5X	3

CONTINUED

All circulation heaters are Assembly Stock unless otherwise noted.

#### Availability

**Assembly Stock:** Five to seven working days

**Standard:** 10 working days

Truck Shipment only

<sup>②</sup> Standard

<sup>⑤</sup> 240V~(ac) can be wired wye and operated at 480V~(ac) 3-phase to produce 1/3 more kW and watt density.

# Tubular and Process Assemblies

## Circulation Heaters

### 5" 150 lb ANSI Flange—WATROD Element

WATROD Description	kW	Fig. No.	Code No.								Est. Ship.	
			240V~(ac) 1-Phase	No. of Circuits	240V~(ac) 3-Phase	No. of Circuits	480V~(ac) 1-Phase	No. of Circuits	480V~(ac) 3-Phase	No. of Circuits	Weight lbs	(kg)

#### Applications: Forced Air and Gases, Caustic Solutions, Degreasing Solutions

<b>23 W/in<sup>2</sup>⑥</b> Steel Tank 6-Incoloy® (3.6 W/cm <sup>2</sup> )	9	5.1	CFNNA25J10	1	CFNNA25J3	1	CFNNA25J11	1	CFNNA25J5	1	140 (64)
	12	5.2	CFNNA33A10	2	CFNNA33A3	1	CFNNA33A11	1	CFNNA33A5	1	145 (66)
	15	5.2	CFNNA40J10	2	CFNNA40J3	1	CFNNA40J11	1	CFNNA40J5	1	167 (76)
	18	5.3	CFNNA48A10	2	CFNNA48A3	1	CFNNA48A11	1	CFNNA48A5	1	180 (82)
	25	5.4			CFNNA64J3	2	CFNNA64J11	2	CFNNA64J5	1	195 (89)
	30	5.5			CFNNA77A3	2	CFNNA77A11	2	CFNNA77A5	1	220 (100)
<b>23 W/in<sup>2</sup></b> Steel Tank 9-Incoloy® (3.6 W/cm <sup>2</sup> )	14	5.1	CFNNA25J10X	3	CFNNA25J3X	1	CFNNA25J11X	1	CFNNA25J5X	1	140 (66)
	18	5.2	CFNNA33A10X	3	CFNNA33A3X	1	CFNNA33A11X	1	CFNNA33A5X	1	145 (68)
	23	5.2	CFNNA40J10X	3	CFNNA40J3X	3	CFNNA40J11X	1	CFNNA40J5X	1	167 (79)
	27	5.3	CFNNA48A10X	3	CFNNA48A3X	3	CFNNA48A11X	3	CFNNA48A5X	1	180 (86)
	38	5.4			CFNNA64J3X	3	CFNNA64J11X	3	CFNNA64J5X	1	195 (94)
	45	5.5			CFNNA77A3X	3	CFNNA77A11X	3	CFNNA77A5X	3	220 (106)

#### Applications: Lightweight Oils, Degreasing Solutions, Heat Transfer Oils

<b>23 W/in<sup>2</sup></b> Steel Tank 6-Steel (3.6 W/cm <sup>2</sup> )	12	5.2	CFNS733A10	2	CFNS733A3	1	CFNS733A11	1	CFNS733A5	1	145 (66)
	15	5.2	CFNS740J10	2	CFNS740J3	1	CFNS740J11	1	CFNS740J5	1	167 (76)
	18	5.3	CFNS748A10	2	CFNS748A3	3	CFNS748A11	1	CFNS748A5	1	180 (82)
	25	5.4			CFNS764J3	2	CFNS764J11	2	CFNS764J5	1	195 (89)
	30	5.5			CFNS777A3	2	CFNS777A11	2	CFNS777A5	1	220 (100)
<b>23 W/in<sup>2</sup></b> Steel Tank 9-Steel (3.6 W/cm <sup>2</sup> )	18	5.2	CFNS733A10X	3	CFNS733A3X	1	CFNS733A11X	1	CFNS733A5X	1	150 (68)
	23	5.2	CFNS740J10X	3	CFNS740J3X	3	CFNS740J11X	1	CFNS740J5X	1	173 (79)
	27	5.3	CFNS748A10X	3	CFNS748A3X	1	CFNS748A11X	3	CFNS748A5X	1	188 (86)
	38	5.4			CFNS764J3X	3	CFNS764J11X	3	CFNS764J5X	1	206 (94)
	45	5.5			CFNS777A3X	3	CFNS777A11X	3	CFNS777A5X	3	233 (106)

#### Applications: Medium Weight Oils, Heat Transfer Oils, Liquid Paraffin

<b>16 W/in<sup>2</sup>③</b> Steel Tank 6-Incoloy® (2.6 W/cm <sup>2</sup> )	8	5.1			CFNN733A12	1			CFNN733A13	1	145 (66)
	10	5.2			CFNN740J12	1			CFNN740J13	1	167 (76)
	12	5.3			CFNN748A12	1			CFNN748A13	1	180 (82)
<b>16 W/in<sup>2</sup>③</b> Steel Tank 9-Incoloy® (2.6 W/cm <sup>2</sup> )	12	5.1			CFNN733A12X	1			CFNN733A13X	1	150 (68)
	15	5.2			CFNN740J12X	1			CFNN740J13X	1	173 (79)
	18	5.3			CFNN748A12X	1			CFNN748A13X	1	188 (86)

#### Applications: Bunker C and #6 Fuel Oils

<b>8 W/in<sup>2</sup>③</b> Steel Tank 6-Steel (1.3 W/cm <sup>2</sup> )	5	5.2			CFNS740J12	1			CFNS740J13	1	167 (76)
	6	5.3			CFNS748A12	1			CFNS748A13	1	180 (82)
	8	5.4			CFNS764J12	1			CFNS764J13	1	195 (89)
	10	5.5			CFNS777A12	1			CFNS777A13	1	220 (100)
<b>8 W/in<sup>2</sup>③</b> Steel Tank 9-Steel (1.3 W/cm <sup>2</sup> )	7.5	5.2			CFNS740J12X	1			CFNS740J13X	1	173 (79)
	9	5.3			CFNS748A12X	1			CFNS748A13X	1	188 (86)
	12	5.4			CFNS764J12X	1			CFNS764J13X	1	206 (94)
	15	5.5			CFNS777A12X	1			CFNS777A13X	1	233 (106)

All circulation heaters are Assembly Stock unless otherwise noted.

#### Availability

**Assembly Stock:** Five to seven working days

**Standard:** 10 working days

Truck Shipment only

③ Must be operated 3-phase wye only.

⑤ 240V~(ac) can be wired wye and operated at 480V~(ac) 3-phase to produce ½ more kW and watt density.

⑥ Can be wired wye to produce ⅓ of the original kW and watt density (3-phase only).

# Tubular and Process Assemblies

## Circulation Heaters

### 6" Flange

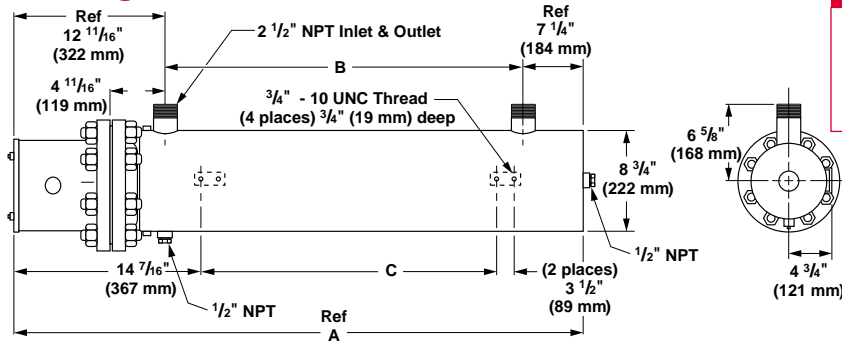

Fig. No.	A Dimension in (mm)	B Dimension in (mm)	C Dimension in (mm)
6.1	40 <sup>7</sup> / <sub>16</sub> (1027)	20 <sup>1</sup> / <sub>2</sub> (521)	17 (432)
6.2	50 <sup>15</sup> / <sub>16</sub> (1294)	31 (787)	27 <sup>1</sup> / <sub>2</sub> (699)
6.3	71 <sup>15</sup> / <sub>16</sub> (1827)	52 (1321)	48 <sup>1</sup> / <sub>2</sub> (1232)
6.4	92 <sup>15</sup> / <sub>16</sub> (2361)	73 (1854)	66 (1676)

### 6" 150 lb ANSI Flange—WATROD Element

WATROD Description	kW	Fig. No.	Code No.								Est. Ship.	
			240V~(ac) 1-Phase	No. of Circuits	240V~(ac) 3-Phase	No. of Circuits	480V~(ac) 1-Phase	No. of Circuits	480V~(ac) 3-Phase	No. of Circuits	Weight lbs	(kg)

#### Application: Clean Water

60 W/in <sup>2</sup> Steel Tank 12-Copper (9.3 W/cm <sup>2</sup> )	24	6.1	CFPC715G10	3	CFPC715G3	2	CFPC715G11	2	CFPC715G5	1	212 (97)
	36	6.1	CFPC721G10	4	CFPC721G3	2	CFPC721G11	2	CFPC721G5	1	217 (99)
	48	6.2			CFPC726R3	4	CFPC726R11	3	CFPC726R5	2	222 (101)
	60	6.2			CFPC732G3	4	CFPC732G11	3	CFPC732G5	2	226 (103)
	72	6.3			CFPC737R3	4			CFPC737R5	2	290 (132)
	100	6.3							CFPC750R5	4	298 (136)
120	6.4							CFPC760G5	4	360 (164)	
60 W/in <sup>2</sup> Steel Tank 15-Copper (9.3 W/cm <sup>2</sup> )	30	6.1	CFPC715G10X	3	CFPC715G3X	5	CFPC715G11X	3	CFPC715G5X	1	215 (98)
	45	6.1	CFPC721G10X	5	CFPC721G3X	5	CFPC721G11X	3	CFPC721G5X	5	223 (102)
	60	6.2			CFPC726R3X	5	CFPC726R11X	3	CFPC726R5X	5	226 (103)
	75	6.2			CFPC732G3X	5	CFPC732G11X	5	CFPC732G5X	5	288 (131)
	90	6.3			CFPC737R3X	5			CFPC737R5X	5	296 (134)
	125	6.3							CFPC750R5X	5	306 (139)
150	6.4							CFPC760G5X <sup>®</sup>	5	370 (168)	

#### Application: Deionized Water, Demineralized Water

60 W/in <sup>2</sup> 316 SS Tank 12-316 SS (9.3 W/cm <sup>2</sup> )	24	6.1	CFPR715N10	3	CFPR715N3	2	CFPR715N11	2	CFPR715N5	1	212 (97)
	36	6.1	CFPR721N10	4	CFPR721N3	2	CFPR721N11	3	CFPR721N5	1	217 (99)
	48	6.2			CFPR727E3	4	CFPR727E11	3	CFPR727E5	2	222 (101)
	60	6.2			CFPR732N3	4	CFPR732N11	3	CFPR732N5	2	226 (103)
	72	6.3			CFPR738E3	4			CFPR738E5	2	290 (132)
	100	6.3							CFPR751E5	4	298 (136)
120	6.4							CFPR760N5	4	360 (164)	
60 W/in <sup>2</sup> 316 SS Tank 15-316 SS (9.3 W/cm <sup>2</sup> )	30	6.1	CFPR715N10X	3	CFPR715N3X	5	CFPR715N11X	3	CFPR715N5X	1	215 (98)
	45	6.1	CFPR721N10X	5	CFPR721N3X	5	CFPR721N11X	3	CFPR721N5X	5	223 (102)
	60	6.2			CFPR727E3X	5	CFPR727E11X	3	CFPR727E5X	5	226 (103)
	75	6.2			CFPR732N3X	5	CFPR732N11X	5	CFPR732N5X	5	288 (131)
	90	6.3			CFPR738E3X	5			CFPR738E5X	5	296 (135)
	125	6.3							CFPR751E5X	5	306 (139)
150	6.4							CFPR760N5X	5	370 (168)	

CONTINUED

All circulation heaters are Assembly Stock unless otherwise noted. © Standard

#### Availability

**Assembly Stock:** Five to seven working days

**Standard:** 10 working days

Truck Shipment only

# Tubular and Process Assemblies

## Circulation Heaters

### 6" 150 lb ANSI Flange—WATROD Element

WATROD Description	kW	Fig. No.	Code No.								Est. Ship.	
			240V~(ac) 1-Phase	No. of Circuits	240V~(ac) 3-Phase	No. of Circuits	480V~(ac) 1-Phase	No. of Circuits	480V~(ac) 3-Phase	No. of Circuits	Weight lbs	(kg)

#### Application: Process Water

<b>48 W/in<sup>2</sup></b> Steel Tank <b>12-Incoloy®</b> (7.5 W/cm <sup>2</sup> )	18	6.1	CFPN713G10	2	CFPN713G3	1	CFPN713G11	1	CFPN713G5	1	212 (97)
	24	6.1	CFPN717R10	3	CFPN717R3	2	CFPN717R11	2	CFPN717R5	1	214 (97)
	30	6.1	CFPN720G10	3	CFPN720G3	2	CFPN720G11	2	CFPN720G5	1	217 (99)
	36	6.1	CFPN725G10	4	CFPN725G3	2	CFPN725G11	2	CFPN725G5	1	222 (101)
	48	6.2			CFPN732R3	4	CFPN732R11	3	CFPN732R5	2	226 (103)
	60	6.3			CFPN740G3	4	CFPN740G11	3	CFPN740G5	2	290 (132)
	72	6.3			CFPN747R3	4			CFPN747R5	2	298 (136)
<b>48 W/in<sup>2</sup></b> Steel Tank <b>15-Incoloy®</b> (7.5 W/cm <sup>2</sup> )	23	6.1	CFPN713G10X	3	CFPN713G3X	5	CFPN713G11X	1	CFPN713G5X	1	215 (98)
	30	6.1	CFPN717R10X	3	CFPN717R3X	5	CFPN717R11X	3	CFPN717R5X	1	217 (99)
	38	6.1	CFPN720G10X	5	CFPN720G3X	5	CFPN720G11X	3	CFPN720G5X	1	223 (102)
	45	6.1	CFPN725G10X	5	CFPN725G3X	5	CFPN725G11X	3	CFPN725G5X	5	226 (103)
	60	6.2			CFPN732R3X	5	CFPN732R11X	3	CFPN732R5X	5	288 (131)
	75	6.3			CFPN740G3X	5	CFPN740G11X	5	CFPN740G5X	5	296 (135)
	90	6.3			CFPN747R3X	5			CFPN747R5X	5	306 (139)

Circulation Heaters

#### Applications: Forced Air and Gases, Caustic Solutions, Degreasing Solutions

<b>23 W/in<sup>2</sup></b> Steel Tank <b>12-Incoloy®</b> (3.6 W/cm <sup>2</sup> )	12	6.1	CFPNA17R10	2	CFPNA17R3	1	CFPNA17R11	1	CFPNA17R5	1	214 (97)
	18	6.1	CFPNA25G10	2	CFPNA25G3	1	CFPNA25G11	1	CFPNA25G5	1	222 (101)
	24	6.2	CFPNA32R10	3	CFPNA32R3	2	CFPNA32R11	2	CFPNA32R5	1	226 (103)
	30	6.3	CFPNA40G10	3	CFPNA40G3	2	CFPNA40G11	2	CFPNA40G5	1	290 (132)
	36	6.3	CFPNA47R10	4	CFPNA47R3	2	CFPNA47R11	2	CFPNA47R5	1	298 (136)
	50	6.4			CFPNA64G3	4	CFPNA64G11	3	CFPNA64G5	2	360 (164)
	60	6.4			CFPNA76R3	4	CFPNA76R11	3	CFPNA76R5	2	368 (167)
<b>23 W/in<sup>2</sup></b> Steel Tank <b>15-Incoloy®</b> (3.6 W/cm <sup>2</sup> )	15	6.1	CFPNA17R10X	3	CFPNA17R3X	1	CFPNA17R11X	1	CFPNA17R5X	1	217 (99)
	23	6.1	CFPNA25G10X	3	CFPNA25G3X	5	CFPNA25G11X	1	CFPNA25G5X	1	226 (103)
	30	6.2	CFPNA32R10X	3	CFPNA32R3X	5	CFPNA32R11X	3	CFPNA32R5X	1	288 (131)
	38	6.3	CFPNA40G10X	5	CFPNA40G3X	5	CFPNA40G11X	3	CFPNA40G5X	1	296 (135)
	45	6.3	CFPNA47R10X	5	CFPNA47R3X	5	CFPNA47R11X	3	CFPNA47R5X	5	306 (139)
	63	6.4			CFPNA64G3X	5	CFPNA64G11X	3	CFPNA64G5X	5	370 (168)
	75	6.4			CFPNA76R3X	5	CFPNA76R11X	5	CFPNA76R5X	5	381 (173)

CONTINUED

All circulation heaters are Assembly Stock unless otherwise noted.

**Availability**

**Assembly Stock:** Five to seven working days

**Standard:** 10 working days

Truck Shipment only

- ⑤ 240V~(ac) can be wired wye and operated at 480V~(ac) 3-phase to produce ½ more kW and watt density.
- ⑥ Can be wired wye to produce ½ of the original kW and watt density (3-phase only).

# Tubular and Process Assemblies

## Circulation Heaters

### 6" 150 lb ANSI Flange—WATROD Element

WATROD Description	kW	Fig. No.	Code No.								Est. Ship.	
			240V~(ac) 1-Phase	No. of Circuits	240V~(ac) 3-Phase	No. of Circuits	480V~(ac) 1-Phase	No. of Circuits	480V~(ac) 3-Phase	No. of Circuits	Weight lbs	(kg)

#### Applications: Lightweight Oils, Degreasing Solutions, Heat Transfer Oils

<b>23 W/in<sup>2</sup> Steel Tank</b> 12-Steel (3.6 W/cm <sup>2</sup> )	12	6.1	CFPS717R10	2	CFPS717R3	1	CFPS717R11	1	CFPS717R5	1	214 (97)
	18	6.1	CFPS725G10	2	CFPS725G3	1	CFPS725G11	1	CFPS725G5	1	222 (101)
	24	6.2	CFPS732R10	3	CFPS732R3	2	CFPS732R11	2	CFPS732R5	1	226 (103)
	30	6.3	CFPS740G10	3	CFPS740G3	2	CFPS740G11	2	CFPS740G5	1	290 (132)
	36	6.3	CFPS747R10	4	CFPS747R3	2	CFPS747R11	2	CFPS747R5	1	298 (136)
	50	6.4			CFPS764G3	4	CFPS764G11	3	CFPS764G5	2	360 (164)
	60	6.4			CFPS776R3	4	CFPS776R11	3	CFPS776R5	2	368 (167)
<b>23 W/in<sup>2</sup> Steel Tank</b> 15-Steel (3.6 W/cm <sup>2</sup> )	15	6.1	CFPS717R10X	3	CFPS717R3X	1	CFPS717R11X	1	CFPS717R5X	1	217 (99)
	23	6.1	CFPS725G10X	3	CFPS725G3X	5	CFPS725G11X	1	CFPS725G5X	1	226 (103)
	30	6.2	CFPS732R10X	3	CFPS732R3X	5	CFPS732R11X	3	CFPS732R5X	1	288 (131)
	38	6.3	CFPS740G10X	5	CFPS740G3X	5	CFPS740G11X	3	CFPS740G5X	1	296 (135)
	45	6.3	CFPS747R10X	5	CFPS747R3X	5	CFPS747R11X	3	CFPS747R5X	5	306 (139)
	63	6.4			CFPS764G3X	5	CFPS764G11X	3	CFPS764G5X	5	370 (168)
	75	6.4			CFPS776R3X	5	CFPS776R11X	5	CFPS776R5X	5	381 (173)

#### Applications: Medium Weight Oils, Heat Transfer Oils, Liquid Paraffin

<b>16 W/in<sup>2</sup> Steel Tank</b> 12-Incoloy® (2.6 W/cm <sup>2</sup> )	6	6.1			CFPN713G12	1			CFPN713G13	1	212 (97)
	8	6.1			CFPN717R12	1			CFPN717R13	1	214 (97)
	10	6.1			CFPN720G12	1			CFPN720G13	1	217 (99)
	12	6.1			CFPN725G12	1			CFPN725G13	1	222 (101)
	16	6.2			CFPN732R12	1			CFPN732R13	1	226 (103)
	20	6.3			CFPN740G12	2			CFPN740G13	1	290 (132)
	24	6.3			CFPN747R12	2			CFPN747R13	1	298 (136)
<b>16 W/in<sup>2</sup> Steel Tank</b> 15-Incoloy® (2.6 W/cm <sup>2</sup> )	7.5	6.1			CFPN713G12X	1			CFPN713G13X	1	215 (98)
	10	6.1			CFPN717R12X	1			CFPN717R13X	1	217 (99)
	12.5	6.1			CFPN720G12X	1			CFPN720G13X	1	223 (102)
	15	6.1			CFPN725G12X	1			CFPN725G13X	1	226 (103)
	20	6.2			CFPN732R12X	5			CFPN732R13X	1	288 (131)
	25	6.3			CFPN740G12X	5			CFPN740G13X	1	296 (135)
	30	6.3			CFPN747R12X	5			CFPN747R13X	1	306 (139)

#### Applications: Bunker C and #6 Fuel Oils

<b>8 W/in<sup>2</sup> Steel Tank</b> 12-Steel (1.3 W/cm <sup>2</sup> )	8	6.2			CFPS732R12	1			CFPS732R13	1	226 (103)
	10	6.3			CFPS740G12	1			CFPS740G13	1	290 (132)
	12	6.3			CFPS747R12	1			CFPS747R13	1	298 (136)
	16.5	6.4			CFPS764G12	1			CFPS764G13	1	360 (164)
	20	6.4			CFPS776R12	1			CFPS776R13	1	368 (167)
<b>8 W/in<sup>2</sup> Steel Tank</b> 15-Steel (1.3 W/cm <sup>2</sup> )	10	6.2			CFPS732R12X	1			CFPS732R13X	1	288 (131)
	12.5	6.3			CFPS740G12X	1			CFPS740G13X	1	296 (135)
	15	6.3			CFPS747R12X	1			CFPS747R13X	1	306 (139)
	21	6.4			CFPS764G12X	5			CFPS764G13X	1	370 (168)
	25	6.4			CFPS776R12X	5			CFPS776R13X	1	381 (173)

All circulation heaters are Assembly Stock unless otherwise noted.

Ⓢ Must be operated 3-phase wye only.

#### Availability

**Assembly Stock:** Five to seven working days

**Standard:** 10 working days

Truck Shipment only

# Tubular and Process Assemblies

## Circulation Heaters

### 6" 150 lb ANSI Flange—FIREBAR Element

FIREBAR Description	kW	Fig. No.	Code No.				Est. Ship.	
			240V~(ac) 3-Phase	No. of Circuits	480V~(ac) 3-Phase	No. of Circuits	Weight lbs	(kg)

#### Applications: Process Water, Ethylene Glycol (50%)

45 W/in <sup>2</sup> Steel Tank 15-Incoloy® (7 W/cm <sup>2</sup> )	30	6.1	CFPNF13G27	5			217 (99)
	37.5	6.1	CFPNF16A27	5			220 (100)
	45	6.1	CFPNF18G27	5			223 (102)
	60	6.1	CFPNF22R27	5	CFPNF22R28	5	226 (103)
	75	6.2	CFPNF27R27	5	CFPNF27R28	5	232 (106)
	90	6.2	CFPNF32R27	5	CFPNF32R28	5	236 (107)
	120	6.3			CFPNF42G28	5	304 (138)
	150	6.3			CFPNF51R28	5	314 (143)

#### Applications: Cooking Oils, Ethylene Glycol (100%)

30 W/in <sup>2</sup> Steel Tank 15-Incoloy® (4.7 W/cm <sup>2</sup> )	25	6.1	CFPNF16J12	5	CFPNF16J13	5	220 (100)
	32	6.1	CFPNF19J12	5	CFPNF19J13	5	223 (102)
	42	6.1	CFPNF24J12	5	CFPNF24J13	5	226 (103)
	52	6.2	CFPNF30A12	5	CFPNF30A13	5	232 (106)
	64	6.2	CFPNF35A12	5	CFPNF35A13	5	236 (107)
	85	6.3	CFPNF45J12	5	CFPNF45J13	5	304 (138)
	110	6.3			CFPNF56A13	5	314 (143)

#### Applications: Heat Transfer Oils, Mineral Oil, Degreasing Solutions

23 W/in <sup>2</sup> Steel Tank 15-Incoloy® (3.6 W/cm <sup>2</sup> )	19	6.1	CFPNF16J20	5			220 (100)
	24	6.1	CFPNF19J20	5			223 (102)
	32	6.1	CFPNF24J20	5	CFPNF24J19	5	226 (103)
	40	6.2	CFPNF30A20	5	CFPNF30A19	5	232 (106)
	48	6.2	CFPNF35A20	5	CFPNF35A19	5	236 (107)
	64	6.3	CFPNF45J20	5	CFPNF45J19	5	304 (138)
	80	6.3	CFPNF56A20	5	CFPNF56A19	5	314 (143)

#### Applications: Medium Weight Oils, Heat Transfer Oils, Lube Oils, Liquid Paraffin

15 W/in <sup>2</sup> Steel Tank 15-Incoloy® (2.3 W/cm <sup>2</sup> )	10	6.1	CFPNF13G29	5			217 (99)
	12.5	6.1	CFPNF16A29	5			220 (100)
	15	6.1	CFPNF18G29	5			223 (102)
	20	6.1	CFPNF22R29	5	CFPNF22R30	5	226 (103)
	25	6.2	CFPNF27R29	5	CFPNF27R30	5	232 (106)
	30	6.2	CFPNF32R29	5	CFPNF32R30	5	236 (107)
	40	6.3	CFPNF42G29	5	CFPNF42G30	5	304 (138)
	50	6.3	CFPNF51R29	5	CFPNF51R30	5	314 (143)

#### Applications: Bunker C and #6 Fuel Oils, Asphalt

8 W/in <sup>2</sup> Steel Tank 15-Incoloy® (1.3 W/cm <sup>2</sup> )	6.3	6.1	CFPNF16J22	5			220 (100)
	8.1	6.1	CFPNF19J22	5			223 (102)
	10.6	6.1	CFPNF24J22	5	CFPNF24J21	5	226 (103)
	13.1	6.2	CFPNF30A22	5	CFPNF30A21	5	232 (106)
	16	6.2	CFPNF35A22	5	CFPNF35A21	5	236 (107)
	21.3	6.3	CFPNF45J22	5	CFPNF45J21	5	304 (138)
	26	6.3	CFPNF56A22	5	CFPNF56A21	5	314 (143)

All circulation heaters are Assembly Stock unless otherwise noted.

③ Must be operated 3-phase wye only.

④ Wired for higher voltage.

#### Availability

**Assembly Stock:** Five to seven working days

Truck Shipment only

# Tubular and Process Assemblies

## Circulation Heaters

### 8" Flange

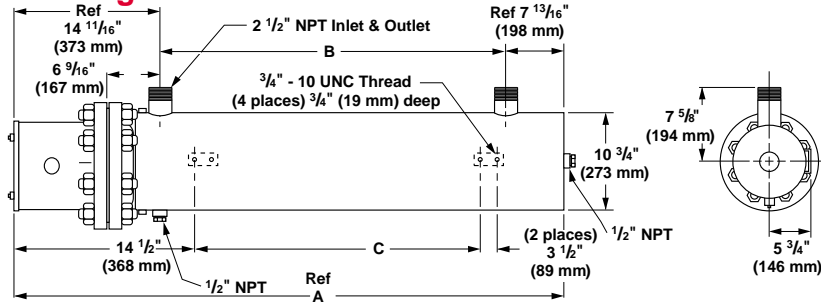

Fig. No.	A Dimension in (mm)	B Dimension in (mm)	C Dimension in (mm)
7.1	47 <sup>1</sup> / <sub>16</sub> (1199)	24 <sup>1</sup> / <sub>16</sub> (627)	21 <sup>7</sup> / <sub>16</sub> (538)
7.2	55 <sup>7</sup> / <sub>16</sub> (1402)	32 <sup>1</sup> / <sub>16</sub> (830)	29 <sup>7</sup> / <sub>16</sub> (741)
7.3	62 <sup>7</sup> / <sub>16</sub> (1580)	39 <sup>1</sup> / <sub>16</sub> (1008)	36 <sup>7</sup> / <sub>16</sub> (919)
7.4	69 <sup>13</sup> / <sub>16</sub> (1773)	47 <sup>7</sup> / <sub>16</sub> (1202)	43 <sup>13</sup> / <sub>16</sub> (1113)
7.5	79 <sup>7</sup> / <sub>16</sub> (2014)	56 <sup>13</sup> / <sub>16</sub> (1443)	53 <sup>7</sup> / <sub>16</sub> (1354)
7.6	88 <sup>7</sup> / <sub>16</sub> (2243)	65 <sup>7</sup> / <sub>16</sub> (1672)	62 <sup>7</sup> / <sub>16</sub> (1583)
7.7	98 <sup>7</sup> / <sub>16</sub> (2497)	75 <sup>13</sup> / <sub>16</sub> (1926)	72 <sup>7</sup> / <sub>16</sub> (1837)

### 8" 150 lb ANSI Flange—WATROD Element

WATROD Description	kW	Fig. No.	Code No.								Est. Ship. Weight (kg)
			240V~(ac) 1-Phase	No. of Circuits	240V~(ac) 3-Phase	No. of Circuits	480V~(ac) 1-Phase	No. of Circuits	480V~(ac) 3-Phase	No. of Circuits	

#### Application: Clean Water

60 W/in <sup>2</sup> Steel Tank 18-Copper (9.3 W/cm <sup>2</sup> )	50	7.1			CFRC721N3②	3	CFRC721N11	3	CFRC721N5	2	340 (155)
	75	7.2			CFRC729N3②	6			CFRC729N5②	2	360 (164)
	100	7.3			CFRC737E3②	6			CFRC737E5	3	385 (175)
	125	7.4			CFRC745E3②	6			CFRC745E5②	3	410 (186)
	150	7.5							CFRC752N5②	6	440 (200)
	175	7.6							CFRC760N5②	6	465 (211)
	200	7.7							CFRC768E5②	6	510 (232)

#### Application: Process Water

48 W/in <sup>2</sup> Steel Tank 18-Incoloy® (7.5 W/cm <sup>2</sup> )	50	7.2			CFRN725N3②	3	CFRN725N11②	3	CFRN725N5②	2	350 (159)
	75	7.3			CFRN735N3②	6			CFRN735N5②	2	380 (173)
	100	7.4			CFRN744E3	6			CFRN744E5	3	410 (186)
	125	7.5			CFRN754M3②	6			CFRN754M5②	6	445 (202)
	150	7.6							CFRN763M5②	6	490 (223)
	175	7.7							CFRN773D5	6	530 (241)
	200	7.7							CFRN782M5②	6	560 (254)
48 W/in <sup>2</sup> Steel Tank 24-Incoloy® (7.5 W/cm <sup>2</sup> )	67	7.2			CFRN726D3X②	4	CFRN726D11X②	3	CFRN726D5X②	2	358 (163)
	100	7.3			CFRN736D3X②	8			CFRN736D5X②	4	392 (178)
	133	7.4			CFRN744M3X②	8			CFRN744M5X②	4	425 (193)
	167	7.5			CFRN754M3X②	8			CFRN754M5X②	8	463 (210)
	200	7.6							CFRN763M5X②	8	511 (232)
	233	7.7							CFRN773D5X	8	554 (252)
	267	7.7							CFRN782M5X②	8	587 (267)

#### Applications: Forced Air and Gases, Caustic Solutions, Degreasing Solutions

23 W/in <sup>2</sup> Steel Tank 18-Incoloy® (3.6 W/cm <sup>2</sup> )	30	7.2	CFRNA32N10②	3	CFRNA32N3②	2	CFRNA32N11②	2	CFRNA32N5②	1	370 (168)
	40	7.3			CFRNA43E3②	3	CFRNA43E11②	2	CFRNA43E5②	2	410 (186)
	50	7.4			CFRNA51M3②	3	CFRNA51M11	3	CFRNA51M5	2	440 (200)
23 W/in <sup>2</sup> Steel Tank 24-Incoloy® (3.6 W/cm <sup>2</sup> )	40	7.2	CFRNA33D10X②	4	CFRNA33D3X②	4	CFRNA33D11X②	2	CFRNA33D5X②	2	382 (174)
	53	7.3			CFRNA43M3X②	4	CFRNA43M11X②	3	CFRNA43M5X②	2	425 (193)
	67	7.4			CFRNA51M3X②	4	CFRNA51M11X②	3	CFRNA51M5X②	2	457 (207)

CONTINUED

All circulation heaters are Assembly Stock unless otherwise noted.

#### Availability

**Assembly Stock:** Five to seven working days

**Standard:** 10 working days

Truck Shipment only

② Standard

⑤ 240V~(ac) can be wired wye and operated at 480V~(ac) 3-phase to produce 1/2 more kW and watt density.

⑥ Can be wired wye to produce 1/2 of the original kW and watt density (3-phase only).

# Tubular and Process Assemblies

## Circulation Heaters

### 8" 150 lb ANSI Flange—WATROD Element

WATROD Description	kW	Fig. No.	Code No.								Est. Ship. Weight	
			240V~(ac) 1-Phase	No. of Circuits	240V~(ac) 3-Phase	No. of Circuits	480V~(ac) 1-Phase	No. of Circuits	480V~(ac) 3-Phase	No. of Circuits	lbs	(kg)

#### Applications: Lightweight Oils, Degreasing Solutions, Heat Transfer Oils

<b>23 W/in<sup>2</sup> Steel Tank</b> 18-Steel (3.6 W/cm <sup>2</sup> )	30.0	7.2	CFRS732N10 <sup>②</sup>	3	CFRS732N3 <sup>②</sup>	2	CFRS732N11 <sup>②</sup>	2	CFRS732N5 <sup>②</sup>	1	370 (168)
	40.0	7.3			CFRS743E3 <sup>②</sup>	3	CFRS743E11 <sup>②</sup>	2	CFRS743E5	2	410 (186)
	50.0	7.4			CFRS751M3	3	CFRS751M11	3	CFRS751M5	2	440 (200)
	60.0	7.5			CFRS762D3 <sup>②</sup>	6	CFRS762D11 <sup>②</sup>	3	CFRS762D5 <sup>②</sup>	2	480 (218)
	70.0	7.6			CFRS770M3 <sup>②</sup>	6	CFRS770M11	6	CFRS770M5	2	530 (241)
	80.0	7.7			CFRS779M3 <sup>②</sup>	6			CFRS779M5 <sup>②</sup>	3	610 (277)
<b>23 W/in<sup>2</sup> Steel Tank</b> 24-Steel (3.6 W/cm <sup>2</sup> )	40.0	7.2	CFRS733D10X <sup>②</sup>	4	CFRS733D3X <sup>②</sup>	4	CFRS733D11X <sup>②</sup>	2	CFRS733D5X <sup>②</sup>	2	382 (174)
	53.0	7.3			CFRS743M3X <sup>②</sup>	4	CFRS743M11X <sup>②</sup>	3	CFRS743M5X <sup>②</sup>	2	425 (193)
	67.0	7.4			CFRS751M3X <sup>②</sup>	4	CFRS751M11X <sup>②</sup>	3	CFRS751M5X <sup>②</sup>	2	457 (208)
	80.0	7.5			CFRS762D3X <sup>②</sup>	8	CFRS762D11X <sup>②</sup>	4	CFRS762D5X <sup>②</sup>	4	461 (209)
	93.0	7.6			CFRS770M3X <sup>②</sup>	8	CFRS770M11X <sup>②</sup>	6	CFRS770M5X <sup>②</sup>	4	554 (252)
	107.0	7.7			CFRS779M3X <sup>②</sup>	8			CFRS779M5X <sup>②</sup>	4	636 (289)

#### Applications: Medium Weight Oils, Heat Transfer Oils, Liquid Paraffin

<b>16 W/in<sup>2</sup> Steel Tank</b> 18-Incoloy <sup>®</sup> (2.6 W/cm <sup>2</sup> )	17.0	7.2			CFRN725N12 <sup>②</sup>	1			CFRN725N13 <sup>②</sup>	1	350 (159)
	25.0	7.3			CFRN735N12 <sup>②</sup>	2			CFRN735N13 <sup>②</sup>	1	380 (173)
	33.0	7.4			CFRN744E12 <sup>②</sup>	2			CFRN744E13	1	410 (186)
	42.0	7.5			CFRN754M12 <sup>②</sup>	3			CFRN754M13 <sup>②</sup>	2	445 (202)
	50.0	7.6							CFRN763M13 <sup>②</sup>	2	490 (223)
	58.0	7.7							CFRN773D13	2	530 (241)
<b>16 W/in<sup>2</sup> Steel Tank</b> 24-Incoloy <sup>®</sup> (2.6 W/cm <sup>2</sup> )	67.0	7.7			CFRN782M13 <sup>②</sup>	2	560 (254)				
	23.0	7.2			CFRN726D12X <sup>②</sup>	2			CFRN726D13X <sup>②</sup>	1	358 (163)
	33.0	7.3			CFRN736D12X <sup>②</sup>	2			CFRN736D13X <sup>②</sup>	1	392 (178)
	44.0	7.4			CFRN744M12X <sup>②</sup>	4			CFRN744M13X <sup>②</sup>	2	425 (193)
	56.0	7.5			CFRN754M12X <sup>②</sup>	4			CFRN754M13X <sup>②</sup>	2	463 (210)
	67.0	7.6							CFRN763M13X <sup>②</sup>	2	511 (232)
	77.0	7.7							CFRN773D13X <sup>②</sup>	2	554 (252)
89.0	7.7					CFRN782M13X <sup>②</sup>			4	587 (267)	

#### Applications: Bunker C and #6 Fuel Oils

<b>8 W/in<sup>2</sup> Steel Tank</b> 18-Steel (1.3 W/cm <sup>2</sup> )	12.5	7.3			CFRS743E12 <sup>②</sup>	1			CFRS743E13 <sup>②</sup>	1	410 (186)
	16.5	7.4			CFRS751M12	1			CFRS751M13	1	440 (200)
	20.0	7.5			CFRS762D12 <sup>②</sup>	2			CFRS762D13 <sup>②</sup>	1	480 (218)
	24.0	7.6			CFRS770M12	2			CFRS770M13	1	530 (241)
	27.0	7.7			CFRS779M12 <sup>②</sup>	2			CFRS779M13 <sup>②</sup>	1	610 (277)
<b>8 W/in<sup>2</sup> Steel Tank</b> 24-Steel (1.3 W/cm <sup>2</sup> )	17.0	7.3			CFRS743M12X <sup>②</sup>	1			CFRS743M13X <sup>②</sup>	1	425 (193)
	22.0	7.4			CFRS751M12X <sup>②</sup>	2			CFRS751M13X <sup>②</sup>	1	457 (208)
	27.0	7.5			CFRS762D12X <sup>②</sup>	2			CFRS762D13X <sup>②</sup>	1	461 (209)
	32.0	7.6			CFRS770M12X <sup>②</sup>	2			CFRS770M13X <sup>②</sup>	1	554 (252)
	36.0	7.7			CFRS779M12X <sup>②</sup>	2			CFRS779M13X <sup>②</sup>	1	636 (289)

All circulation heaters are Assembly Stock unless otherwise noted.

② Standard

③ Must be operated 3-phase wye only.

#### Availability

**Assembly Stock:** Five to seven working days

**Standard:** 10 working days

Truck Shipment only

# Tubular and Process Assemblies

## Circulation Heaters

### 10" Flange

Fig. No.	A Dimension in (mm)	B Dimension in (mm)	C Dimension in (mm)
8.1	76 <sup>9</sup> / <sub>16</sub> (1945)	60 <sup>13</sup> / <sub>16</sub> (1545)	67 <sup>9</sup> / <sub>16</sub> (1716)
8.2	84 <sup>1</sup> / <sub>16</sub> (2135)	68 <sup>5</sup> / <sub>16</sub> (1735)	75 <sup>1</sup> / <sub>16</sub> (1907)
8.3	91 <sup>3</sup> / <sub>16</sub> (2316)	75 <sup>1</sup> / <sub>16</sub> (1916)	82 <sup>3</sup> / <sub>16</sub> (2088)
8.4	99 <sup>1</sup> / <sub>16</sub> (2516)	83 <sup>5</sup> / <sub>16</sub> (2116)	90 <sup>1</sup> / <sub>16</sub> (2288)
8.5	106 <sup>7</sup> / <sub>16</sub> (2707)	90 <sup>13</sup> / <sub>16</sub> (2307)	97 <sup>9</sup> / <sub>16</sub> (2478)

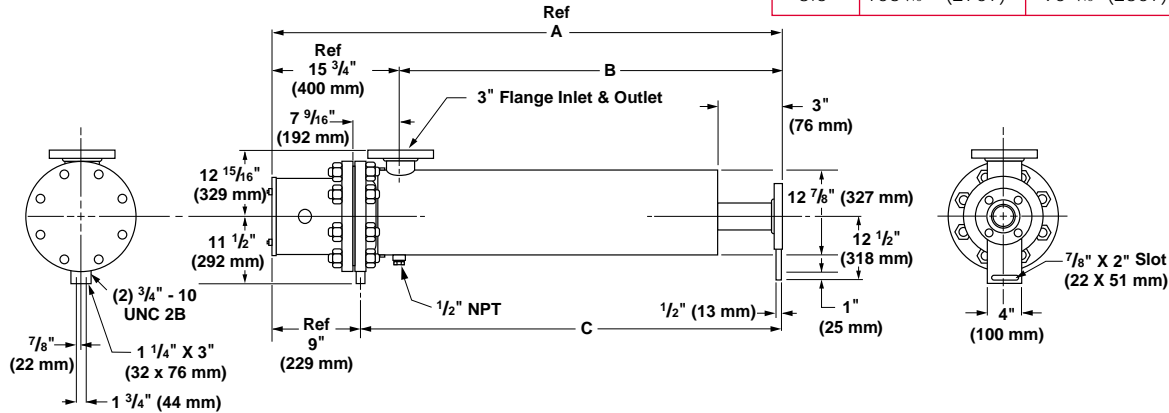

### 10" 150 lb ANSI Flange—WATROD Element

WATROD Description	kW	Fig. No.	Code No.				Est. Ship.	
			240V~(ac) 3-Phase	No. of Circuits	480V~(ac) 3-Phase	No. of Circuits	Weight lbs (kg)	

#### Application: Process Water

48 W/in <sup>2</sup> ⑤ Steel Tank 27-Incoloy® (7.5 W/cm <sup>2</sup> )	262	8.5			CFSS773E5	9	600 (273)
---	-----	-----	--	--	-----------	---	-----------

#### Applications: Forced Air and Gases, Caustic Solutions, Degreasing Solutions

23 W/in <sup>2</sup> ⑤⑥ Steel Tank 27-Incoloy® (3.6 W/cm <sup>2</sup> )	60	8.1	CFSNA43N3②	3	CFSNA43N5②	3	515 (234)
	75	8.2	CFSNA51N3②	9	CFSNA51N5	3	530 (241)

#### Applications: Lightweight Oils, Degreasing Solutions, Heat Transfer Oils

23 W/in <sup>2</sup> Steel Tank 27-Steel (3.6 W/cm <sup>2</sup> )	90	8.3			CFSS762E5②	3	540 (245)
	105	8.4			CFSS770N5	3	600 (272)
	120	8.5			CFSS778N5②	3	645 (293)

#### Applications: Medium Weight Oils, Heat Transfer Oils, Liquid Paraffin

16 W/in <sup>2</sup> ③ Steel Tank 27-Incoloy® (2.6 W/cm <sup>2</sup> )	75	8.3			CFSS763N13②	3	540 (245)
	87	8.5			CFSS773E13②	3	600 (273)

#### Applications: Bunker C and #6 Fuel Oils

8 W/in <sup>2</sup> ③ Steel Tank 27-Steel (1.3 W/cm <sup>2</sup> )	30	8.3	CFSS762E12②	3	CFSS762E13②	1	540 (245)
	35	8.4	CFSS770N12	3	CFSS770N13	1	600 (273)
	40	8.5	CFSS778N12②	3	CFSS778N13②	1	645 (293)

All circulation heaters are Assembly Stock unless otherwise noted.

#### Availability

**Assembly Stock:** Five to seven working days

**Standard:** 10 working days

■ Truck Shipment only

② Standard

③ Must be operated 3-phase wye only.

⑤ 240V~(ac) can be wired wye and operated at 480V~(ac) 3-phase to produce 1/2 more kW and watt density.

⑥ Can be wired wye to produce 1/2 of the original kW and watt density (3-phase only).

# Tubular and Process Assemblies

## Circulation Heaters

### 12" Flange

Fig. No.	A Dimension in (mm)	B Dimension in (mm)	C Dimension in (mm)
9.1	76 7/8 (1953)	60 1/16 (1541)	67 13/16 (1722)
9.2	84 3/8 (2143)	68 3/16 (1732)	75 5/16 (1913)
9.3	91 1/8 (2334)	75 11/16 (1922)	82 3/16 (2103)
9.4	99 (2515)	82 13/16 (2103)	89 15/16 (2284)
9.5	106 1/2 (2705)	90 5/16 (2294)	97 1/16 (2475)

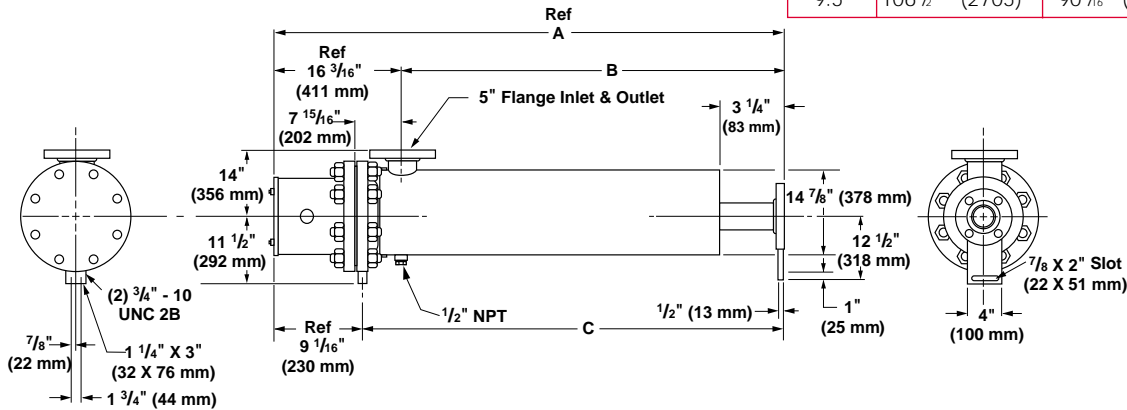

Circulation Heaters

### 12" 150 lb ANSI Flange—WATROD Element

WATROD Description	kW	Fig. No.	Code No.				Est. Ship.	
			240V~(ac) 3-Phase	No. of Circuits	480V~(ac) 3-Phase	No. of Circuits	Weight lbs	(kg)

#### Application: Process Water

48 W/in <sup>2</sup> Steel Tank	350	9.5			CFTN773C5	12	650 (295)
36-Incoloy® (7.5 W/in <sup>2</sup> )							

#### Applications: Forced Air and Gases, Caustic Solutions, Degreasing Solutions

23 W/in <sup>2</sup> Steel Tank	80	9.1			CFTNA43L5②	3	565 (257)
36-Incoloy® (3.6 W/cm <sup>2</sup> )	100	9.2			CFTNA51L5	3	585 (266)

#### Applications: Lightweight Oils, Degreasing Solutions, Heat Transfer Oils

23 W/in <sup>2</sup> Steel Tank	140	9.4			CFTS770L5	4	650 (295)
36-Steel (3.6 W/cm <sup>2</sup> )	160	9.5			CFTS778L5②	4	700 (318)

#### Applications: Medium Weight Oils, Heat Transfer Oils, Liquid Paraffin

16 W/in <sup>2</sup> ③ Steel Tank	117	9.5			CFTN773C13②	3	650 (295)
36-Incoloy® (2.6 W/cm <sup>2</sup> )							

#### Applications: Bunker C and #6 Fuel Oils

8 W/in <sup>2</sup> ③ Steel Tank	47	9.4	CFTS770L12②	3	CFTS770L13	2	700 (318)
36-Steel (1.3 W/cm <sup>2</sup> )	54	9.5	CFTS778L12②	3	CFTS778L13②	2	750 (341)

All circulation heaters are Assembly Stock unless otherwise noted.

#### Availability

**Assembly Stock:** Five to seven working days

**Standard:** 10 working days

■ Truck Shipment only

② Standard

③ Must be operated 3-phase wye only.

# Tubular and Process Assemblies

## Circulation Heaters

### 14" Flange

Fig. No.	A Dimension in (mm)	B Dimension in (mm)	C Dimension in (mm)
10.1	75 3/4 (1924)	59 7/16 (1510)	66 1/2 (1689)
10.2	83 1/4 (2115)	66 15/16 (1700)	74 (1880)
10.3	90 3/4 (2305)	74 7/16 (1891)	81 1/2 (2070)
10.4	98 1/4 (2496)	81 15/16 (2081)	89 (2261)
10.5	105 3/4 (2686)	89 7/16 (2272)	96 1/2 (2451)

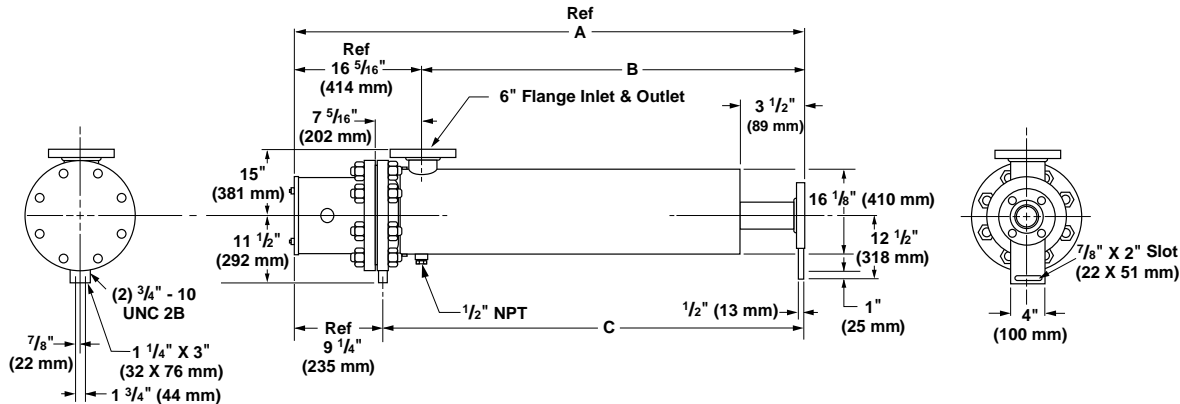

### 14" 150 lb ANSI Flange—WATROD Element

WATROD Description	kW	Fig. No.	Code No.				Est. Ship.	
			240V~(ac) 3-Phase	No. of Circuits	480V~(ac) 3-Phase	No. of Circuits	Weight lbs (kg)	

#### Application: Process Water

48 W/in <sup>2</sup> Steel Tank	315	10.2			CFWN754J5②	15	600 (273)
45-Incoloy® (7.5 W/cm <sup>2</sup> )	375	10.3			CFWN763J5②	15	650 (295)

#### Applications: Forced Air and Gases, Caustic Solutions, Degreasing Solutions

23 W/in <sup>2</sup> Steel Tank	100	10.1			CFWNA43J5②	3	570 (259)
45-Incoloy® (3.6 W/cm <sup>2</sup> )	125	10.2			CFWNA51J5	5	590 (268)

#### Applications: Lightweight Oils, Degreasing Solutions, Heat Transfer Oils

23 W/in <sup>2</sup> Steel Tank	150	10.3			CFWS762A5②	5	650 (295)
45-Steel (3.6 W/cm <sup>2</sup> )	175	10.4			CFWS770J5	5	700 (318)
	200	10.5			CFWS778J5②	5	780 (354)

#### Applications: Medium Weight Oils, Heat Transfer Oils, Liquid Paraffin

16 W/in <sup>2</sup> Steel Tank	105	10.2			CFWN754J13②	3	600 (273)
45-Incoloy® (2.6 W/cm <sup>2</sup> )	125	10.3			CFWN763J13②	5	650 (295)

#### Applications: Bunker C and #6 Fuel Oils

8 W/in <sup>2</sup> Steel Tank	60	10.4	CFWS770J12②	3	CFWS770J13	3	700 (318)
45-Steel (1.3 W/cm <sup>2</sup> )	67	10.5	CFWS778J12②	5	CFWS778J13②	3	780 (354)

All circulation heaters are Assembly Stock unless otherwise noted.

#### Availability

**Assembly Stock:** Five to seven working days

**Standard:** 10 working days

■ Truck Shipment only

② Standard

③ Must be operated 3-phase wye only.

# Tubular and Process Assemblies

F.O.B.: Hannibal, Missouri

## Circulation Heaters

### Build-a-Code

**Circulation Heater Base Code Number** \_\_\_\_\_

General purpose (NEMA 1) terminal enclosure standard

**Optional Terminal Enclosure Type** \_\_\_\_\_

- S** = General purpose with thermostat (NEMA 1)
- W** = Moisture resistant (NEMA 4)
- E** = Explosion resistant (NEMA 7)
- E/W** = Explosion/moisture resistant (NEMA 7/4)

**Optional Thermostat<sup>①</sup> or Thermocouple<sup>②</sup>** \_\_\_\_\_

- ① Thermostat code numbers shown on [page 425](#). Check sensing bulb O.D. against thermowell I.D. to assure proper fit. For side-mount thermostats, also assure adequate capillary tube length.
- ② Specify Type J or K thermocouple. If overtemp thermocouple specify orientation horizontal, vertical up or vertical down.

Circulation Heaters

### How to Order

To order a stock circulation heater, please specify:

- Watlow code number
- Volts/watts
- Phase
- Flange or screw plug size
- Tank material
- Options
- Quantity

If the circulation heater is to be configured with options, add the suffix letter(s) to the circulation heater base code number, as indicated on the Build-a-Code chart.

If stock units do not meet your application needs, Watlow can provide **made-to-order** heaters. Please provide:

- Application (including vessel orientation)
- Volts/watts
- Phase
- Number of circuits
- Watt density
- Sheath material and number of heating elements
- Flange or screw plug size
- Tank material
- Inlet and outlet mating type and size
- Centerline of inlet and outlet
- Terminal enclosure type
- Options
- Quantity

### Availability

**Assembly Stock:** Five to seven working days

**Modified Stock<sup>Ⓢ</sup>:** Five-10 working days

**Standard:** 10 working days

**Made-to-Order:** Six to eight weeks

Options, complexity and quantity may affect availability and lead times. Consult factory.

### Replacement Heater Assemblies Only

Replacement heater assemblies available by ordering circulation heater code number and specifying "replacement heater only."

<sup>Ⓢ</sup> Assembly Stock units with catalog options.

# Tubular and Process Assemblies

## Circulation Heaters

### Booster Heaters

#### Booster Heaters

Booster heaters are ideal for circulating applications requiring less kilowatts, including engine preheating.

Booster heaters are made from a steel or brass 1¼" NPT screw plug heater and insulated pressure vessel with 1" FNPT inlet and outlet. This assembly also contains an integral thermostat.

#### Performance Capabilities

- Watt densities to 60 W/in<sup>2</sup> (9.3 W/cm<sup>2</sup>)
- Wattages to 3kW
- Voltages to 480V~(ac)
- Steel sheath temperatures to 750°F (400°C)
- Copper sheath temperatures to 350°F (175°C)

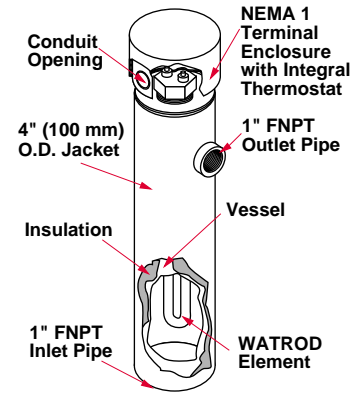

#### Features and Benefits

- **Dual voltages** simplify stocking and wiring.
- **Carbon steel, standard pipe wall vessel** is compatible with many applications.
- **One inch thick (25 mm) fiberglass thermal insulation**, rated to 750°F (400°C), reduces heat loss.
- **Steel jacket (shroud)** is fully welded and painted to protect thermal insulation.

- **Inlet and outlet nozzle connections** are one inch FNPT fittings welded to the vessel.
- **General purpose (NEMA 1) terminal enclosure** protects terminals and thermostat.
- **Integral thermostat controls** process temperatures from:  
60° to 160°F (15° to 70°C) on copper sheath elements  
175° to 550°F (80° to 290°C) on steel sheath elements

#### Applications

- Stand by generators
- Peak power trimming generators
- Mobile generator sets
- Earth-moving equipment
- Water heaters
- Lightweight oils

## Options

### Terminal Enclosure

General purpose (NEMA 1) terminal enclosures with integral thermostats are supplied on all Watlow booster heaters. Optional moisture resistant (NEMA 4) terminal enclosures

protect wiring and thermostat from liquid contaminants. To order, add the suffix letter **W** to the booster heater base code number.

For explosion resistant (NEMA 7) and explosion/moisture resistant (NEMA 7/4) terminal enclosures, see **Screw Plug Immersion Heaters, pages 322 to 324.**

# Tubular and Process Assemblies

F.O.B.: Hannibal, Missouri

## Circulation Heaters Booster Heaters

Description	kW	Phase	Code No. 120/240V~(ac)	Est. Ship. Weight lbs (kg)
-------------	----	-------	---------------------------	-------------------------------

### Application: Aqueous Solutions

60 W/in <sup>2</sup>	1.5	1	CBEC8G6	18 (8.2)
Brass Plug	2.0	1	CBEC10F6	18 (8.2)
2-Copper	2.5	1	CBEC12F6	18 (8.2)
(9.3 W/cm <sup>2</sup> )	3.0	1	CBEC15A6X	18 (8.2)

### Application: Lightweight Oils

23 W/in <sup>2</sup>	0.5	1	CBES7G6	18 (8.2)
Steel Plug	0.75	1	CBES10B6	18 (8.2)
2- Steel	1.0	1	CBES12P6	18 (8.2)
(3.6 W/cm <sup>2</sup> )				

All units are Assembly Stock

For optional housing adders use circulation heater adders.

#### Availability

**Assembly Stock:** Five to seven days

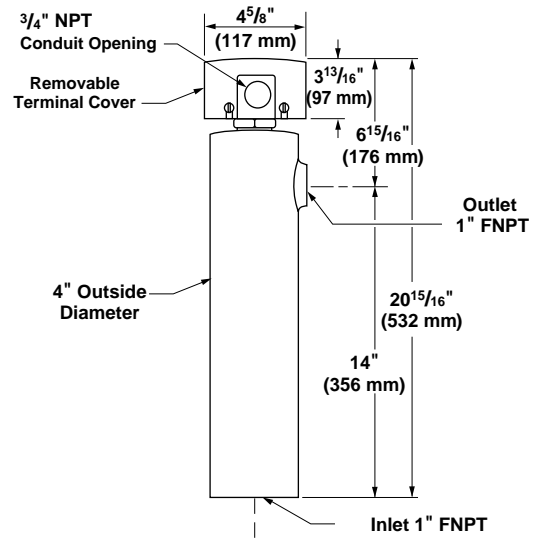

Circulation Heaters

### How to Order

To order a booster heater, please specify:

- Watlow code number
- Volts/watts
- Options
- Quantity

If the booster heater requires an optional NEMA 4 terminal enclosure, add the suffix letter **W** to the base code number.

If our Assembly Stock units do not meet your application needs, Watlow can provide a made-to-order unit. For **made-to-order** units, consult your Watlow representative and provide the following information:

- Application
- Volts/watts
- Watt density
- Phase
- Terminal enclosure type
- Options
- Quantity

### Availability

**Assembly Stock:** Five to seven working days

**Modified Stock**<sup>Ⓛ</sup>: Five to seven working days

**Made-to-Order:** Six to eight weeks

Options, complexity and quantity may affect availability and lead times. Consult factory.

<sup>Ⓛ</sup> Assembly Stock units with catalog options.

# Tubular and Process Assemblies

## Circulation Heaters

### Engine Preheaters

Watlow engine preheaters help maintain a desired minimum engine temperature to make starting fast and easy. Also reduces engine wear caused by cold engine starting.

Engine preheaters mount conveniently on an engine or rail. The internal thermostat constantly adjusts to ambient temperature changes to keep engine coolant warm at all times.

An internal tank temperature sensor protects Watlow engine preheaters from dry fire conditions caused by low coolant levels or blocked flow.

Installation is easy with just two mounting bolts, and inlet and outlet hose connections.

#### Performance Capabilities

- Watt densities from 45 to 90 W/in<sup>2</sup> (7 to 14 W/cm<sup>2</sup>)
- Up to 6 kW
- UL® and CSA component recognition to 480V~(ac) and 600V~(ac) respectively.
- Thermostatically controlled from 60 to 160°F (15 to 70°C)
- Incoloy® sheath temperatures to 1600°F (870°C)

#### Features and Benefits

- **Incoloy® sheath** minimizes the risk of premature failure in the event of a dry-fire condition.
- **Integral, prewired adjustable thermostat**, mounted in a general purpose (NEMA 1) terminal enclosure provides a ready-to-install unit.
- **Easy installation with standard, one inch (25 mm) diameter beaded inlet and outlet nozzles.** Rubber hose connections eliminate the need for threaded fittings and adapters.
- **120/240V~(ac) or 240/480V~(ac) dual voltages** make field wiring flexible. Minimizes stocking multiple voltages.
- **Mounting bracket** isolates harmful engine vibration.
- **Heavy-duty welded carbon steel tank** resists corrosion and extends life.
- **Optional oil pressure interconnect switch** disrupts power during engine operation.



- **Integral check valve** assures proper coolant flow and correct thermostat operation. Check valve will not interfere with adequate thermo-siphoning.
- **UL® and CSA component** recognition under file numbers E52951 and 31388 respectively. See **pages 268 to 271** for details.

#### Applications

- Standby generators
- Primary power generators
- Firepump engines

## Options

### Terminal Enclosures

The following terminal enclosures are available:

- Standard, general purpose (NEMA 1)
- Moisture resistant (NEMA 4)

- Explosion resistant (NEMA 7) class 1, groups C and D. For class 1, group B enclosures, consult your Watlow representative.

Order by adding the suffix letter **W** (NEMA 4) or **E** (NEMA 7) to the engine preheater base code number.

### Threaded Nozzles

Carbon steel threaded inlets and outlets are available for installations using rigid piping or threaded adapters. Threaded nozzles are

typically supplied for firepump applications. To order, specify **threaded nozzles** and **NPT size**.

# Tubular and Process Assemblies

F.O.B.: Hannibal, Missouri

## Circulation Heaters

### Engine Preheaters

#### Application Hints

- Mount engine preheaters in horizontal position only (as shown in Figures #1, #2 and #3). Consult your Watlow representative if vertical mounting is unavoidable.
- Mount the heater near or below the lowest point on the engine block. Keep outlet nozzle pointed up, as indicated on the tank.
- Estimate kilowatt requirements with the following formula. First determine the engine displacement, then multiply:

**English**  
Cubic inches X 3 = estimated wattage

**Metric**  
Liters X 183 = estimated wattage

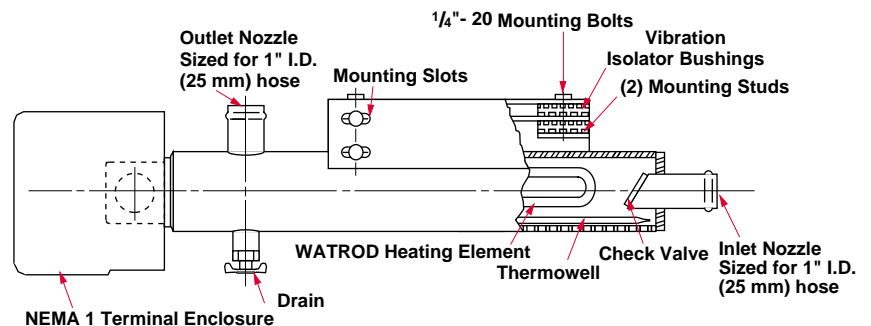
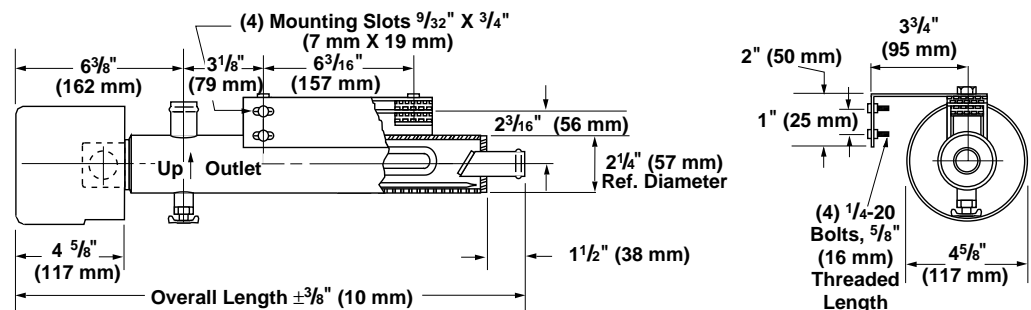

Figure 1



kW	Overall Length Inch (mm)	Code No.			Est. Ship.	
		120/240V~(ac) 1-Phase	208V~(ac) 1-Phase	240/480V~(ac) 1-Phase	lbs	(kg)

#### Application: Ethylene Glycol/Engine Coolant

1.13	20 7/8 (530)	CPBPB6S12	CPBPL2S12①		12 (6)
1.50	20 7/8 (530)		CPBPB2S12①		12 (6)
1.69	20 7/8 (530)		CPBPM2S12①		12 (6)
1.88	20 7/8 (530)		CPBPN2S12①		12 (6)
2.00	20 7/8 (530)	CPBPC6S12			12 (6)
2.25	20 7/8 (530)	CPBPD6S12			12 (6)
2.25	26 1/16 (678)		CPBPD2S12①		15 (7)
2.50	20 7/8 (530)	CPBPE6S12			12 (6)
3.00	26 1/16 (678)		CPBPF2S12①	CPBPF7S12	15 (7)
3.75	26 1/16 (678)		CPBPG2S12①		15 (7)
4.00	26 1/16 (678)			CPBPH7S12	15 (7)
5.00	26 1/16 (678)			CPBPJ7S12①	15 (7)

All preheaters are Stock unless otherwise noted.

① Standard

#### Availability

**Stock:** Same day shipment

**Standard:** Four weeks

# Tubular and Process Assemblies

F.O.B.: Hannibal, Missouri

## Circulation Heaters Engine Preheaters

Figure 2

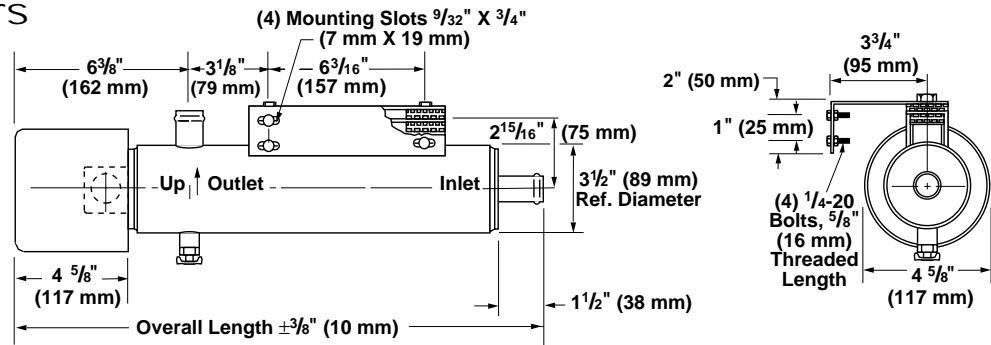

kW	Overall Length Inch (mm)	Code No.		Est. Ship. Weight lbs (kg)
		277V~(ac) 1-Phase	480V~(ac) 3-Phase	

**Application: Ethylene Glycol/Engine Coolant**

1.5	20% (530)	CPCPB4S12 <sup>Ⓢ</sup>	CPCPB13S12 <sup>Ⓢ</sup>	12 (6)
2.0	20% (530)	CPCPC4S12 <sup>Ⓢ</sup>	CPCPC13S12 <sup>Ⓢ</sup>	12 (6)
2.5	20% (530)	CPCPE4S12 <sup>Ⓢ</sup>	CPCPE13S12 <sup>Ⓢ</sup>	12 (6)
3.75	20% (530)	CPCPG4S12 <sup>Ⓢ</sup>	CPCPG13S12 <sup>Ⓢ</sup>	12 (6)
4.0	20% (530)	CPCPH4S12 <sup>Ⓢ</sup>	CPCPH13S12	12 (6)
5.0	20% (530)	CPCPJ4S12 <sup>Ⓢ</sup>	CPCPJ13S12	12 (6)

Figure 3

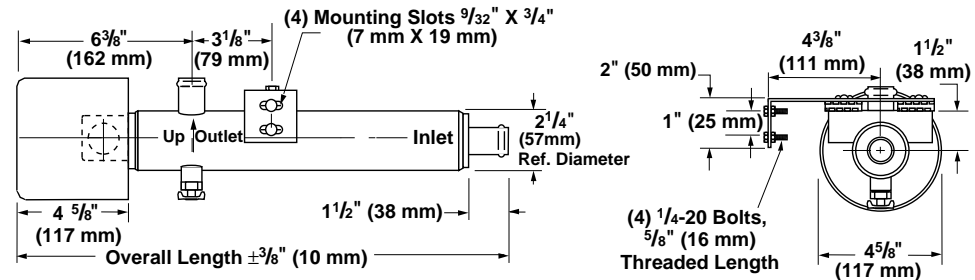

kW	Overall Length Inch (mm)	Code No.		Est. Ship. Weight lbs (kg)
		120/240V~(ac) 1-Phase	208V~(ac) 1-Phase	

**Application: Ethylene Glycol/Engine Coolant**

0.75	15% (397)		CPBPK2S12 <sup>Ⓢ</sup>	9 (4)
1.0	15% (397)	CPBPA6S12 <sup>Ⓢ</sup>		9 (4)

All preheaters are stock unless otherwise noted.

**Availability**

**Stock:** Same day shipment

**Standard:** Four weeks

Ⓢ Standard

**How to Order**

To order a Stock, or Standard engine preheater, please specify:

- Code number
- Volts/watts
- Phase
- Options
- Quantity

If our Stock units do not meet your application needs, Watlow will

provide a made-to-order unit. For **made-to-order** units, provide the following information:

- Volts/watts
- Phase
- Inlet and outlet type and size
- Terminal enclosure type
- Mounting orientation
- Options
- Quantity

**Availability**

**Stock:** Same day shipment

**Modified Stock<sup>Ⓢ</sup>:** Five to seven working days

**Standard:** Four weeks

**Made-to-Order:** Six to eight weeks

Options, complexity and quantity may affect availability and lead times. Consult factory.

<sup>Ⓢ</sup> Stock units with catalog options.

## Tubular and Process Assemblies

### Circulation Heaters

#### Pipe Insert Heaters

Pipe insert immersion heaters permit removing and servicing the heater bundle without draining the liquid being heated.

Heating is accomplished by mounting a flange or screw plug immersion heater inside a pressure-tight bayonet pipe vessel. The pipe vessel then mates to a flange connection on a storage tank's side. Heat transfer between element(s) and tank contents is accomplished by heating the air or heat transfer fluid inside the bayonet pipe for conduction to the tank's contents.

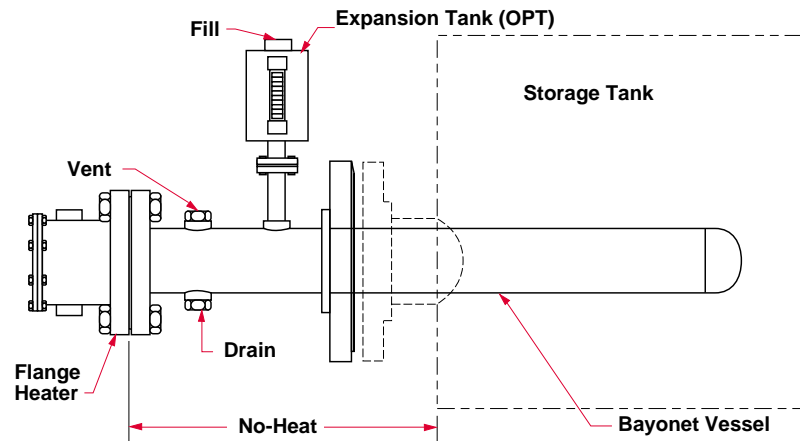

#### Performance Capabilities

- Wattages to 100kW
- Voltages to 600V~(ac)
- Ratings to 600 lb pressure class
- Incoloy® sheath temperatures to 1400°F (760°C)
- Stainless steel sheath temperatures to 1200°F (650°C)
- Steel sheath temperatures to 750°F (400°C)

#### Features and Benefits

- **Low watt density screw plug or flange heaters**, mounted in the bayonet vessel, provide long life.

- **Carbon steel, 304 and 316 stainless steel bayonet vessels** offer compatibility with a wide range of liquids.
- **Welded flange on pipe vessel** ensures pressure seal.
- **Heating element support(s)** ensure proper element spacing and maximum heater performance.
- **Heat transfer fluid fill/drain and vent couplings** ease installation and maintenance.

#### Applications

- Indirect heating of viscous fluids:
  - Asphalt
  - Tar
  - Molasses
  - Syrup
  - Glue
- Corrosive liquids
- Degreasing fluids

#### Options

Pipe insert heaters can be supplied with a variety of options, including:

- Appropriate gasket materials
- Passivation cleaning on pipe insert
- European screw plug to flange adapters
- CSA certified terminal enclosures
- Stand-off terminal enclosures
- Thermocouple temperature sensors
- Thermostats
- Customer specified materials, sizes and pressure class ratings

For descriptions and ordering information about these options, please refer to **Flange Immersion Heaters, pages 340 to 343**, or **Screw Plug Immersion Heaters, pages 322 to 326**.

#### Flanges

Flanges to 24 inches nominal pipe size are available in materials compatible with specific application

needs. For information on flange materials and ratings, consult your Watlow representative.

## Circulation Heaters Pipe Insert Heaters

### **Bayonet Vessels**

Bayonet vessels are available up to 14 inches nominal pipe size and 20 feet long. Vessel size is dependent upon the kW

requirement and element watt density. For more information, please consult your Watlow representative.

### **Application Hints**

- Mount pipe insert heater horizontally.
- Locate pipe insert heaters low in the tank, but above the sludge level.
- Consider a low liquid level sensor to protect against low liquid level conditions.
- Select the proper heat transfer media (air or fluid) to adequately

conduct heat from the elements to the bayonet vessel. Consult your Watlow representative for recommendations.

- Select a watt density that's compatible with the heat transfer media being used.
- Use a sheath high-limit sensing device inside the bayonet vessel to protect against element over-heating.

- For pipe insert heater assemblies employing heat transfer fluid, use an expansion tank. This will allow for fluid expansion and contraction during heater cycling.
- Insulate the pipe insert heater's exterior to minimize heat loss.



### **Caution:**

Do not insulate the terminal enclosure.

### **How to Order**

All pipe insert heaters are **made-to-order**. To order, please specify:

- Application
- Volts/watts
- Phase
- Number of circuits
- Bayonet vessel material
- Storage tank mating flange size

- Maximum bayonet length beyond the storage tank mating flange
- Dimension from heater flange to inside of storage tank wall
- Terminal enclosure type
- Options
- Quantity

### **Availability**

**Made-to-Order:** Six to eight weeks  
Options, complexity and quantity may affect availability and lead times. Consult factory.

## Tubular and Process Assemblies

### Quick Ship

On stock chart units:

- Five to seven days on all heaters
- 10 working days on special voltages and/or wattages
- 15 working days on special element lengths

### Over-the-Side Heaters

To provide portability, easy installation and removal, Watlow makes Over-the-Side heaters in three versions:

- "L" and "O" shaped
- Vertical loop
- Drum

These "installed-from-the-top" heaters slide easily into tanks, with the heated portion immersed along the side or at the bottom.

Over-the-Side heaters are ideal for heating water, oils, solvents, salts and acids. Application versatility is enhanced with optional sheath materials, kilowatt ratings, terminal enclosures and mounting methods.

#### "L" and "O" Shaped Performance Capabilities

- Incoloy® sheath element watt densities to 60 W/in<sup>2</sup> (9.3 W/cm<sup>2</sup>)
- Steel sheath element watt densities to 23 W/in<sup>2</sup> (3.6 W/cm<sup>2</sup>)
- Wattages to 50kW
- Voltages to 600V~(ac)

#### Features and Benefits

- **Rugged, light-weight construction** resists damage during installation or removal.
- **Three 0.475 inch (12 mm) diameter WATROD heating elements** offer one- or three-phase operation.
- **WATROD hairpins are repressed (recompacted)** after bending to assure MgO density, dielectric strength, heat transfer and life.
- **Four inch (100 mm) sludge legs** keep heating elements off the tank's bottom to help avoid being covered with sediment.
- **RTV riser seal** prevents moisture from infiltrating electrical areas.

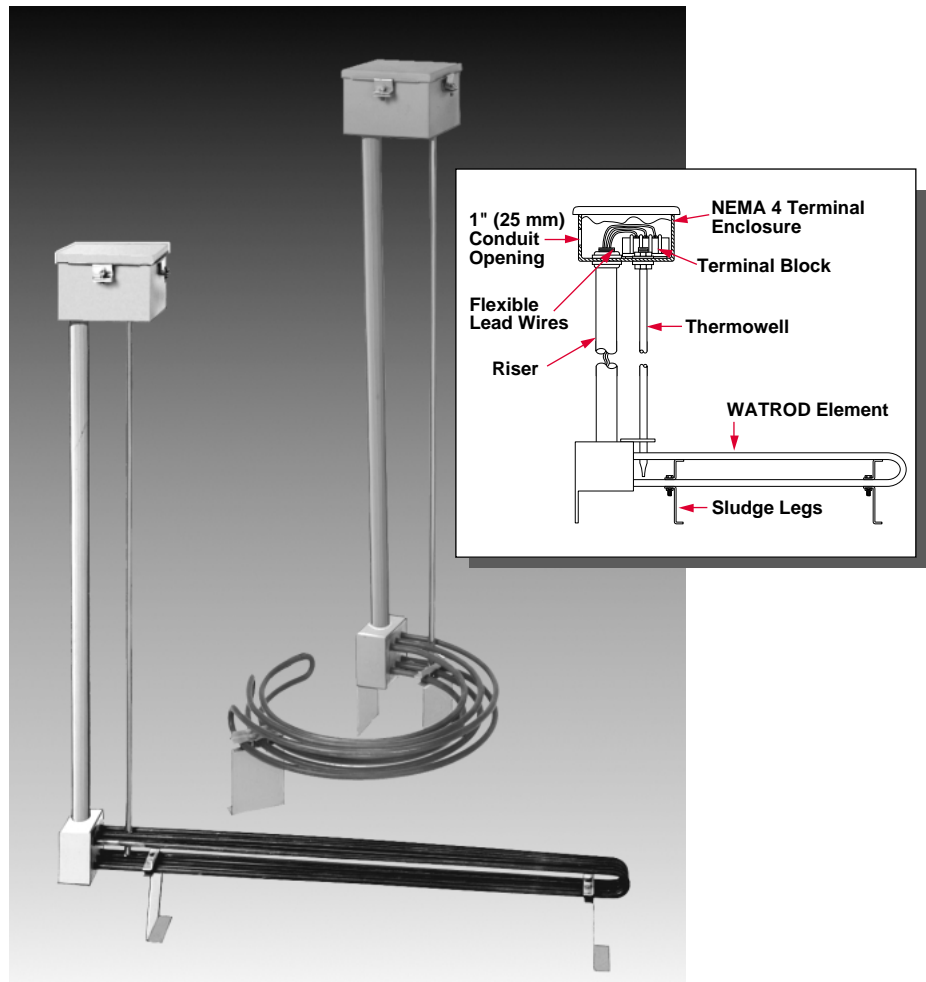

- **Standard size one inch conduit openings** facilitate wiring.
- **SRG insulated flexible lead wires**, rated to 390°F (200°C), allow factory or field wiring for three or one phase operation.
- **Riser materials are compatible with element sheath materials:** *Stainless steel with Incoloy® sheath*  
*Steel with steel sheath*  
All other wetted parts are stainless steel.
- **Integral thermowells** provide convenient temperature sensor insertion and replacement without draining the fluid being heated.
- **Moisture resistant (NEMA 4) enclosures** standard.
- **UL® and CSA component recognition** to 480V~(ac) and 600V~(ac) under file numbers E52951 and 31388 respectively.

#### Applications

- Water heating
- Freeze protection
- Viscous oils
- Storage tanks
- Degreasing tanks
- Solvents
- Salts
- Caustic solutions
- Paraffin

Incoloy® is a registered trademark of Special Metals Corporation.

UL® is a registered trademark of Underwriter's Laboratories, Inc.

# Tubular and Process Assemblies

## Over-the-Side Heaters

### L and O Shaped Options



#### Caution

Explosion-resistant terminal enclosures are intended to provide explosion containment in the electrical termination/wiring enclosure only. No portion of the assembly outside of this enclosure is covered under this rating. Rating effectiveness may be compromised by abuse or misapplication.

#### Terminal Enclosures

Moisture resistant (NEMA 4) terminal enclosures, without thermostats, are standard on all Watlow "L" and "O" shaped Over-the-Side heaters. Optional terminal enclosures meet application requirements with:

- Corrosion resistant (NEMA 4X). Available with or without a single or double pole thermostat.
- Explosion resistant (NEMA 7) class 1 groups C and D. Available with or without a single or double pole thermostat. For class 1, group B enclosures, consult your Watlow representative.
- Explosion/moisture resistant

(NEMA 7/4) combinations.

Available with or without a single or double pole thermostat.

Terminal enclosures without thermostats may be ordered by specifying the appropriate suffix code:

**E** for explosion resistant (NEMA 7)

**E/W** for explosion/moisture resistant (NEMA 7/4).

No suffix code is needed for corrosion resistant (NEMA 4X); simply specify terminal enclosure and rating.

To order a thermostat with a terminal enclosure, add the code number to the Over-the-Side heater base code number.

#### Thermostats

Optional single and double pole thermostats are also available separately.

For details on thermostats, see *Thermostats*, [pages 423 to 425](#).

#### Thermocouples

ASTM Type J or K thermocouples offer more accurate sensing of process and/or sheath temperatures. A thermocouple may be inserted into the thermowell or attached to the heater's sheath.

Thermocouples are supplied with 120 inch (3050 mm) leads (longer lead lengths available). Unless otherwise specified, thermocouples are supplied with temperature ranges detailed on the *Thermocouple Types* chart.

Thermocouples require an appropriate temperature and power control. These must be purchased separately. Watlow offers a wide variety of temperature and power controls to meet virtually all applications. Temperature controls can be configured to accept process variable inputs, too. Consult your Watlow representative for details.

To order, specify **Type J** or **K** thermocouple, **lead length**, and indicate if it is for measuring **process** temperature or as a **high-limit** sensing device.

<sup>①</sup> Type J and Type K thermocouples are rated 32 to 1382°F and 32 to 2282°F (0-750°C and 0-1250°C), respectively. Watlow does not recommend exceeding temperature ranges shown on this chart for the tubular product line.

Alumel® and Chromel® are registered trademarks of the Hoskins Manufacturing Company.

#### Thermocouple Types

ASTM Type	Conductor Characteristics		Recommended <sup>①</sup> Temperature Range	
	Positive	Negative	°F	(°C)
J	Iron (Magnetic)	Constantan (Non-magnetic)	0 to 1000	(-20 to 540)
K	Chromel® (Non-magnetic)	Alumel® (Magnetic)	0 to 2000	(-20 to 1100)

## Tubular and Process Assemblies

### Over-the-Side Heaters

#### **L and O Shaped Options**

Continued

#### **Wattages and Voltages**

Watlow routinely supplies Over-the-Side heaters with 240 to 480V~(ac) as well as wattages from three to 18 kilowatts. If required, Watlow can

configure heaters with voltages and wattages outside these parameters. For more information about this option, consult your Watlow representative.

#### **Multiple Elements**

Over-the-Side immersion heaters are configured with three WATROD heating elements.

To achieve a specific kilowatt rating, Watlow can configure units with up

to 18 heating elements.

To order, specify **multiple elements**, the **number of elements**, **volts**, **watts**, **phase** and **maximum bundle height** and **width**.

#### **Sheath Material**

Stock "O" and "L" shaped Over-the-Side heaters come with Incoloy® or steel sheaths. 304 or 316 stainless

steel and titanium sheaths are available upon request.

To order, specify the **sheath material**.

#### **Passivation**

During the manufacturing process, particles of iron or tool steel may become embedded in the stainless steel or alloy sheath. If not removed, these particles may corrode,

produce rust spots and/or contaminate the process.

For critical applications, passivation will remove free iron from the sheath and other wetted surfaces.

To order, specify **passivation**.

#### **Riser**

A stainless steel or steel riser is supplied to keep terminal enclosures out of the heated solution. Stock heights are 39<sup>5</sup>/<sub>16</sub> or 51<sup>5</sup>/<sub>16</sub> inches (1000 or 1320 mm). Upon request, riser height up to 60 feet (18.3 m) can be provided.

To order, specify **riser material** and **height**.

#### **Right Angle Riser**

Riser may be right angle formed to move the terminal enclosure away from over the tank.

To order, specify **right angle riser** and **dimensions**.

#### **Sludge Legs**

Four inch (100 mm) sludge legs are supplied on all stock units to keep elements above sediments. Shorter

or longer sludge legs are available upon request.

To order, specify **sludge legs** and **height**.

#### **Man Hole Cover**

A man hole cover seals the tank and provides heater mounting.

Man hole covers are pre-assembled to the riser. Standard man hole

covers are made from steel with other materials available upon request.

To order, specify **man hole construction**, **diameter** and **material**.

# Tubular and Process Assemblies

F.O.B.: Hannibal, Missouri

## Over-the-Side Heaters

### L and O Shaped

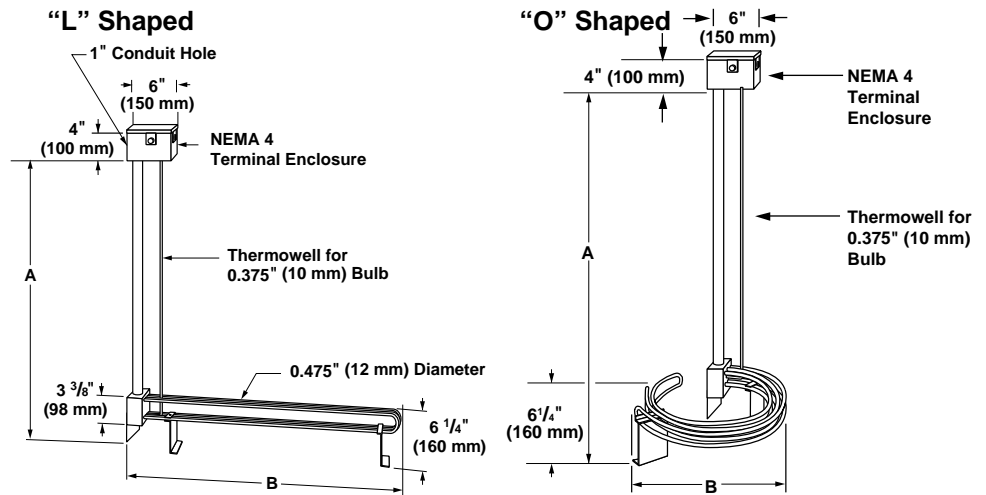

### "L" Shaped

WATROD Description	kW	A Dimension		B Dimension		Code No.		Est. Ship. Weight
		inch	(mm)	inch	(mm)	240V~(ac) 3-Phase	480V~(ac) 3-Phase	

Applications: Process Water, Mild Caustic Solutions (2% Max), Clean Water

48 W/in <sup>2</sup>	3	39 5/16	(1000)	14 3/8	(370)	OLN714L3W	OLN714L13W <sup>①</sup>	30 (14)
Incoloy® (7.5 W/cm <sup>2</sup> )	6	39 5/16	(1000)	22 3/8	(575)	OLN722L3W	OLN722L5W	40 (19)
	9	39 5/16	(1000)	30 1/8	(765)	OLN730C3W	OLN730C5W	45 (21)
	12	51 5/16	(1300)	37 3/8	(955)	OLN737L3W	OLN737L5W	50 (23)
	15	51 5/16	(1300)	45 1/8	(1145)	OLN745C3W	OLN745C5W	65 (30)
	18	51 5/16	(1300)	52 3/8	(1335)	OLN752L3W	OLN752L5W	75 (34)

Applications: Citric and Phosphoric Acid Solutions, Caustic Solutions, Water Based Solutions

23 W/in <sup>2</sup>	3	39 5/16	(1000)	22 3/8	(575)	OLNA22L3W	OLNA22L5W	40 (19)
Incoloy® (3.6 W/cm <sup>2</sup> )	6	51 5/16	(1300)	37 3/8	(955)	OLNA37L3W	OLNA37L5W	50 (23)
	9	51 5/16	(1300)	52 3/8	(1335)	OLNA52L3W	OLNA52L5W	75 (34)

Applications: Lightweight Oils, Degreasing Solutions, Mineral Oil

23 W/in <sup>2</sup>	3	39 5/16	(1000)	22 3/8	(575)	OLS722L3W	OLS722L5W	40 (19)
Steel (3.6 W/cm <sup>2</sup> )	6	51 5/16	(1300)	37 3/8	(955)	OLS737L3W	OLS737L5W	50 (23)
	9	51 5/16	(1300)	52 3/8	(1335)	OLS752L3W	OLS752L5W	75 (34)

### "O" Shaped

WATROD Description	kW	A Dimension		B Dimension		Code No.		Est. Ship. Weight
		inch	(mm)	inch	(mm)	240V~(ac) 3-Phase	480V~(ac) 3-Phase	

Applications: Process Water, Mild Caustic Solutions (2% Max), Clean Water

48 W/in <sup>2</sup>	3	39 5/16	(1000)	10 3/8	(270)	ORN710N3W	ORN710N13W <sup>①</sup>	30 (14)
Incoloy® (7.5 W/cm <sup>2</sup> )	6	39 5/16	(1000)	13 1/2	(345)	ORN713J3W	ORN713J5W	40 (19)
	9	39 5/16	(1000)	16	(405)	ORN716A3W	ORN716A5W	45 (21)
	12	51 5/16	(1300)	18 1/2	(470)	ORN718J3W	ORN718J5W	50 (23)
	15	51 5/16	(1300)	21 1/2	(540)	ORN721E3W	ORN721E5W	65 (30)
	18	51 5/16	(1300)	23 1/2	(595)	ORN723J3W	ORN723J5W	75 (34)

Applications: Citric and Phosphoric Acid Solutions, Caustic Solutions, Water Based Solutions

23 W/in <sup>2</sup>	3	39 5/16	(1000)	13 1/2	(345)	ORNA13J3W	ORNA13J5W	40 (19)
Incoloy® (3.6 W/cm <sup>2</sup> )	6	51 5/16	(1300)	18 1/2	(470)	ORNA18J3W	ORNA18J5W	50 (23)
	9	51 5/16	(1300)	23 1/2	(595)	ORNA23J3W	ORNA23J5W	75 (34)

Applications: Lightweight Oils, Degreasing Solutions, Mineral Oil

23 W/in <sup>2</sup>	3	39 5/16	(1000)	13 1/2	(345)	ORS713J3W	ORS713J5W	40 (19)
Steel (3.6 W/cm <sup>2</sup> )	6	51 5/16	(1300)	18 1/2	(470)	ORS718J3W	ORS718J5W	50 (23)
	9	51 5/16	(1300)	23 1/2	(595)	ORS723J3W	ORS723J5W	75 (34)

All units are Assembly Stock.

#### Availability

Assembly Stock: Five to seven working days

Truck Shipment only

① Must be operated 3-phase only.

# Tubular and Process Assemblies

F.O.B.: Hannibal, Missouri

## Over-the-Side Heaters

### L and O Shaped

#### Base Code Number

Includes moisture resistant (NEMA 4) terminal enclosure without thermostat

#### Enclosure with Thermostat

See chart below for order code suffix

Thermostat	Temperature		Max. A Dimension		Code No. Suffix		
	°F	(°C)	inch	(mm)	Moisture Resistant	Explosion Resistant	Exp./Moist. Resistant
Single Pole Single Throw (SPST) ①	30-250	(0-120)	84	(2135)	<b>2A</b>	<b>E2A</b>	<b>E/W2A</b>
	175-550	(80-290)	84	(2135)	<b>3A</b>	<b>E3A</b>	<b>E/W3A</b>
	300-700	(150-350)	60	(1525)	<b>10</b>	<b>E10</b>	<b>E/W10</b>
Double Pole Single Throw (DPST) ②	60-250	(15-120)	52	(1320)	<b>5</b>	<b>E5</b>	<b>E/W5</b>
	60-250	(15-120)	52	(1320)	<b>5A</b>	<b>E5A</b>	<b>E/W5A</b>
	100-550	(40-290)	60	(1525)	<b>6</b>	<b>E6</b>	<b>E/W6</b>
	100-550	(40-290)	52	(1320)	<b>7</b>	<b>E7</b>	<b>E/W7</b>
	100-550	(40-290)	52	(1320)	<b>7A</b>	<b>E7A</b>	<b>E/W7A</b>
On-Off Manual Reset (DPST)	60-250	(15-120)	55	(1395)	<b>8</b>	<b>E8</b>	<b>E/W8</b>
	100-550	(40-290)	60	(1525)	<b>9</b>	<b>E9</b>	<b>E/W9</b>

① SPST thermostats require an electrical contactor if operated at 480V~(ac); at 240V~(ac) over 22 amps; or wired three phase.

② DPST thermostats require an electrical contactor if operated at 480V~(ac) over 21 amps; at 240V~(ac) over 30 amps; or wired three phase wye.

### How to Order

To order a stock unit, please specify:

- Watlow code number
- Volts/watts
- Phase
- Options
- Quantity

If our stock units do not meet your application needs, Watlow will provide **made-to-order** units. Consult your Watlow representative and provide the following information:

- Application
- Volts/watts
- Phase
- Number of circuits
- Watt density
- Number of heating elements and sheath material
- 'A' dimension
- 'B' dimension
- Options, including terminal enclosure type
- Quantity

### Availability

**Assembly Stock:** Five to seven working days

**Modified Stock** ③: Five to seven working days

**Made-to-Order:** Five to seven weeks  
Options, complexity and quantity may affect availability and lead times. Consult factory.

③ Assembly Stock units with catalog options.

# Tubular and Process Assemblies

## Over-the-Side Heaters

### Vertical Loop Heater

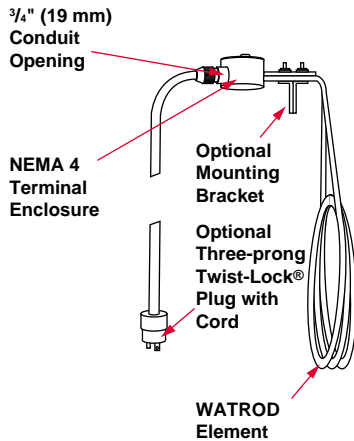

These light-weight, thin-profile vertical loop heaters are well suited for open tank applications.

A WATROD tubular element, formed into spiral loops, hugs the tank wall to maximize tank work space.

Available with four different sheath materials, vertical loop heaters come

with options to meet application requirements.

Versatility is further enhanced with optional three-prong, Twist-Lock® plug and adjustable mounting brackets.

### Performance Capabilities

- Incoloy® sheath watt densities to 60 W/in<sup>2</sup> (9.3 W/cm<sup>2</sup>)
- Titanium sheath watt densities to 45 W/in<sup>2</sup> (7 W/cm<sup>2</sup>)
- Steel sheath watt densities to 23 W/in<sup>2</sup> (3.5 W/cm<sup>2</sup>)
- Wattages to 9kW
- Voltages to 600V~(ac)

### Features and Benefits

- **WATROD element** is filled with compacted MgO insulation to maximize dielectric strength, heat transfer and life.
- **Long no-heat ends** form the heater's riser. No-heat ends leave only the element's looped portion submerged and heated. These are also formed into a right angle to move the terminal enclosure away from over the tank.

- **Moisture resistant (NEMA 4) terminal enclosure** offers easy access to terminal wiring.
- **Terminal enclosure materials** depend on element sheath material. These include:

<b>Cast iron</b>	Incoloy® Steel 316 stainless steel
<b>PVC</b>	Titanium

- **Conduit openings** accept 3/4 inch conduit fittings to facilitate wiring.
- **Screw lug terminals** accept customer supplied ring-type wire terminals.
- **Ground terminals** are supplied to facilitate equipment grounding.

### Applications

- Water heating
- Lightweight oils
- Salt baths
- Mild acid baths
- Cleaning solutions
- Plating solutions

## Options

### Three-prong, Twist-Lock® Plug

An optional flexible cord, with three-prong, Twist-lock® plug, provides easy connection to standard 220V~(ac) outlets. The 70 inch (1780 mm) cord is rubber insulated

to resist oil, ozone, grease, chemicals, acids, solvents, weather and temperature extremes to 195°F (90°C).

To order, add the suffix letter **C** to the heater's base code number.

### Wattages and Voltages

Watlow supplies stock vertical loop heaters as 240V~(ac), with wattages from five to eight kilowatts. To meet specific application needs, Watlow

can configure heaters with voltages and wattages outside these parameters.

For more information about this option, consult your Watlow representative.

### Passivation

During the manufacturing process, particles of iron or tool steel may become embedded in the stainless steel or alloy sheath. If not removed, these particles may corrode,

produce rust spots and/or contaminate the process.

For critical applications, passivation will remove free iron from the sheath.

To order, specify **passivation**.

# Tubular and Process Assemblies

F.O.B.: Hannibal, Missouri

## Over-the-Side Heaters

### Vertical Loop Heater Options

Continued

#### Adjustable Mounting Brackets

To accommodate varying tank wall thicknesses, optional stainless steel mounting brackets adjust from 0 to 4¾ inches (0 to 120 mm).

To order, add suffix letter **B** to the vertical loop heater base code number.

#### Application Hints

- Determine recommended sheath material and watt density by using the **Supplemental Applications Chart** on **pages 263 to 266**. If unable to determine the appropriate sheath material and watt density for the fluid being heated, consult your Watlow representative.

- Ensure conduit openings and fittings are compatible with the environment around the heater enclosure.
- Use optional mounting brackets to position the heating element so there is ample space between the tank wall and the heating element.
- Ensure the liquid level stays above the heater's looped section. If not submerged, it will overheat or create a hazardous situation.
- Remove the heater periodically to inspect and clean the element. This maintenance procedure will prolong the heater's life.

### Vertical Loop Heaters

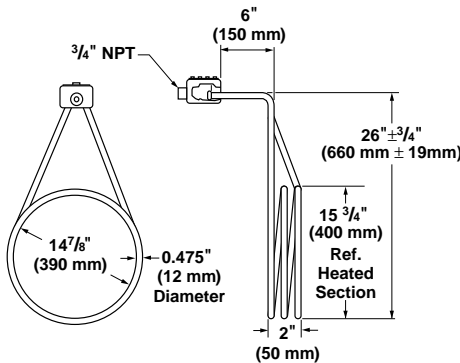

All units are Stock unless otherwise noted.  
**Availability**  
**Stock:** Same day shipment  
**Standard:** Five weeks  
**Made-to-Order:** Eight weeks

Applications	WATROD Description	kW	Code No. 240V~(ac) 1-Phase	Est. Ship. Weight lbs (kg)
Conventional Plating Baths Such as Copper Plating, Cyanide Type; Tin Plating, Alkaline Stannate Type; Brass and Bronze; Nickel, Chrome, Gold and Silver Plating and Iron Chromide. Nitrites, Permanganates, Persulfates and Dichromates.	<b>43 W/in<sup>2</sup> Titanium</b> (6.7 W/cm <sup>2</sup> )	8	<b>VLT10W8</b> ①	28 (13)
Water Heating and Mild Acids	<b>40 W/in<sup>2</sup> Incoloy®</b> (6.2 W/cm <sup>2</sup> )	8	<b>VLN10W8</b>	28 (13)
Mild Acid Baths	<b>40 W/in<sup>2</sup> 316 SS</b> (6.2 W/cm <sup>2</sup> )	8	<b>VLR10W8</b>	28 (13)
Alkaline Solutions Which Do Not Contain Fluorides, Fluoroborates or Fluorosilicates, Pyrophosphate Copper, Ferric Chloride, Iron Chloride; Bright Dips and Pickles Containing Nitric, Phosphoric, and Chromic Acids	<b>27 W/in<sup>2</sup> Titanium</b> (4.2 W/cm <sup>2</sup> )	5	<b>VLT10W5</b> ①	28 (13)
Water Heating, Corrosive Liquids and Salt Baths	<b>23 W/in<sup>2</sup> Incoloy®</b> (3.6 W/cm <sup>2</sup> )	5	<b>VLN10W5</b>	26 (12)
Citrus Juices, Mild Acid Baths and Other Fluids Normally Corrosive to Steel	<b>23 W/in<sup>2</sup> 316 SS</b> (3.6 W/cm <sup>2</sup> )	5	<b>VLR10W5</b>	26 (12)
Oil Tempering Baths, Salt Baths, Alkaline Cleaning Solutions, Cyanide Cleaning Solutions	<b>23 W/in<sup>2</sup> Steel</b> (3.6 W/cm <sup>2</sup> )	5 8	<b>VLS10W5</b> <b>VLS10W8</b>	26 (12) 26 (12)

① Standard

Over-the-Side

# Tubular and Process Assemblies

F.O.B.: Hannibal, Missouri

## Over-the-Side Heaters

### Vertical Loop Heater

#### How to Order

To order a stock vertical loop heater, please specify:

- Watlow code number
- Volts/watts
- Options
- Quantity

If our stock units do not meet your application needs, Watlow will provide **made-to-order** units.

Consult your Watlow representative and provide the following information:

- Application
- Volts/watts
- Watt density
- Dimensions
- No-heat section
- Heating element diameter and sheath material
- Options
- Quantity

#### Availability

**Stock:** Same day shipment

**Modified Stock** ①: Five to seven working days

**Standard:** Three weeks

**Made-to-Order:** Five to seven weeks

Options, complexity and quantity may affect availability and lead times. Consult factory.

① Stock units with catalog options.

### Drum

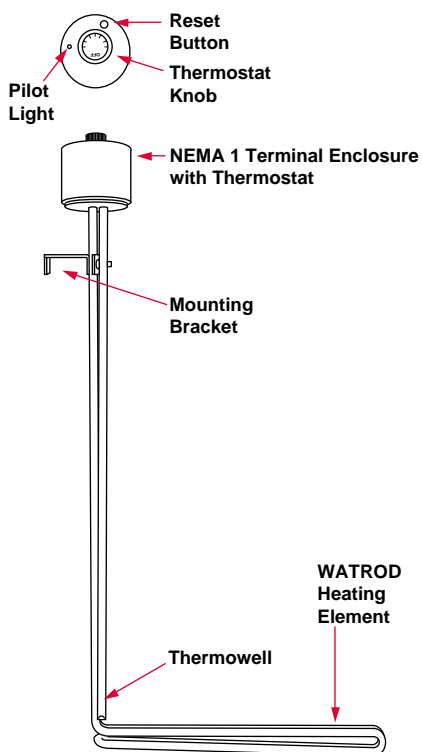

Designed for direct immersion in a standard 55 gallon steel drum, these heaters install easily through the two inch (50 mm) bung hole.

These one to four kilowatt WATROD heaters come prewired with a thermostat, manual reset button and pilot light in a general purpose (NEMA 1) terminal enclosure. This internal tank temperature sensing feature protects against overheating.

#### Performance Capabilities

- Incoloy® sheath watt densities to 60 W/in<sup>2</sup> (9.3 W/cm<sup>2</sup>)
- Wattages to 9kW
- Voltages to 600V~(ac)

#### Features and Benefits

- **Light-weight, rugged construction** resists damage during installation or removal.
- **Stainless steel mounting bracket** adjusts to varying immersion depths to keep the heating element above settled sludge.

- **A 0.475 inch (12 mm) diameter Incoloy® WATROD element** has its hairpins repressed (recompacted) after bending to assure MgO density, dielectric strength, heat transfer and life.
- **Integral, on-off, manual reset, Type 8 thermostat**, rated from 60 to 250°F (15 to 120°C), senses process temperature and helps protect against overheating.
- **Pilot light** indicates if heater is cycled on or off.
- **30 inch (760 mm) long no-heat ends** form the heater's riser. No-heat ends leave only the element's heated portion submerged.
- **General purpose (NEMA 1) terminal enclosure** has one inch (25 mm) conduit openings to facilitate wiring.
- **UL® and CSA component recognition** to 480 and 600V~(ac) maximum under file numbers E52951 and 31388 respectively.

## Tubular and Process Assemblies

### Over-the-Side Heaters

#### Drum

#### Applications

- Melting heat sensitive materials such as wax, lard, grease and coconut oil

- Water and water-based solution heating
- Freeze protection

### Options

#### Terminal Enclosures

A general purpose (NEMA 1) terminal enclosure, with integral thermostat, is supplied on all Watlow drum heaters. As an option, moisture resistant (NEMA 4) and explosion resistant (NEMA 7) terminal

enclosures are available to protect both wiring and the thermostat.

To order, add the suffix letter **W** for moisture resistant (NEMA 4) or **E** for explosion resistant (NEMA 7) to the drum heater's base code number.

#### Wattages and Voltages

Watlow routinely supplies drum heaters in 120, 240 and 480V~(ac) in one or four kilowatt versions. Watlow will configure heaters with

voltages and wattages outside these parameters.

For more information about this option, consult your Watlow representative.

#### Three-prong, Twist-Lock® Plug

An optional flexible cord, with three-prong, Twist-lock® plug, provides easy connection to standard 220V~(ac) outlets. The 70 inch (1780 mm) cord is rubber insulated

to resist oil, ozone, grease, chemicals, acids, solvents, weather and temperature extremes to 195°F (90°C).

To order, add the suffix letter **CP** to the drum heater base code number.

#### Application Hints

- Determine recommended sheath material and watt density by using the **Supplemental Applications Chart** on **pages 263 to 266**. If unable to determine the correct sheath material and watt density, consult your Watlow representative.
- Ensure that the element's heated portion is fully immersed at all times. If the element is not sufficiently submerged, it will overheat and become damaged.
- Use drum heaters only in metal drums.

- Do not use the thermostat as an on-off switch. Use a disconnect switch or circuit breaker to cut power prior to servicing.
- Ensure that conduit openings and fittings are compatible with the environment around the heater enclosure.
- Use the adjustable mounting bracket to raise the heating element above the drum's sludge level.
- Periodically remove the heater to inspect and clean the element. This maintenance procedure will prolong the heater's life.

# Tubular and Process Assemblies

## Over-the-Side Heaters

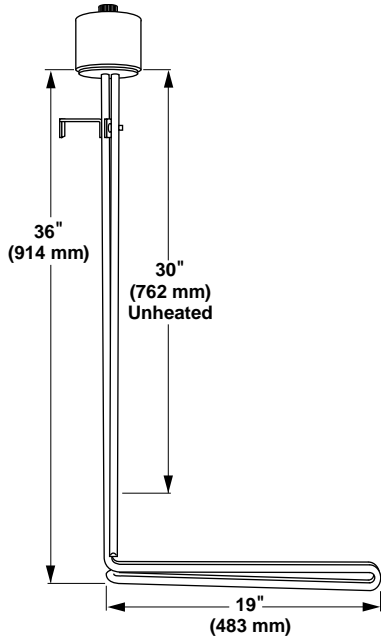

### Drum Heater

WATROD Description	kW	Code No.			Est. Ship. Weight lbs (kg)
		120V~(ac) 1-Phase	240V~(ac) 1-Phase	480V~(ac) 1-Phase	

#### Applications: Solvents, Water and Water Based Solutions

32 W/in <sup>2</sup> Incoloy® (5 W/cm <sup>2</sup> )	4		OLDN10S4	OLDN10S11	35 (16)
--	---	--	----------	-----------	---------

#### Applications: Melting Oils, Lard, Fats, Tar

8 W/in <sup>2</sup> Incoloy® (1.3 W/cm <sup>2</sup> )	1	OLDN1S1	OLDN10S1		35 (16)
---	---	---------	----------	--	---------

All units are stock.

### Availability

**Stock:** Same day shipment

### How to Order

To order a stock drum heater, please specify:

- Watlow code number
- Volts/watts
- Options
- Quantity

If stock units do not meet your application needs, Watlow will provide **made-to-order** units.

Consult your Watlow representative and provide the following:

- Application
- Volts/watts
- Watt density
- Dimensions
- No-heat section
- Heating element diameter and sheath material
- Options
- Quantity

### Availability

**Stock:** Same day shipment

**Modified Stock** <sup>Ⓢ</sup>: Five to seven working days

**Standard:** Three weeks

**Made-to-Order:** Five to seven weeks

Options, complexity and quantity may affect availability and lead times. Consult factory.

<sup>Ⓢ</sup> Stock units with catalog options.

## Tubular and Process Assemblies

### Quick Ship

On stock chart units:

- Three to five working days on most heaters
- 10 working days on special voltages and/or wattages
- 15 working days on special element lengths

### Duct Heaters

Constructed of sturdy 0.430 inch (11 mm) diameter WATROD heating elements mounted to a ¼ inch (6 mm) thick steel flange, duct heaters are easily adapted to many non-pressurized, air-heating systems.

They are easily installed in applications requiring a wide range of temperature vs. air flow combinations.

Watlow duct heaters offer advantages over gas or oil fired and open coil electric units with:

- Installation flexibility—no flues or fuel lines.
- 100 percent energy efficient—no energy loss up the flue.
- Universal availability of electricity.
- Resistance coil in Incoloy® sheath is protected from corrosive environments.

#### Performance Capabilities

- Watt densities to 40 W/in<sup>2</sup> (6.2 W/cm<sup>2</sup>)
- Recommended process temperatures from -20 to 1200°F (-7 to 650°C)
- Wattages to 2.2 megawatts
- Voltages to 600V~(ac)

#### Features and Benefits

- **Long life Incoloy® sheath** resists corrosion/oxidation while protecting resistance coils against contamination.
- **MgO insulation filled elements**, compacted to rock hard density maximize dielectric strength, heat transfer and life.
- **Field replaceable heating elements** permit easy service and reduce downtime. Element change-out is made simple by a single screw clamp.

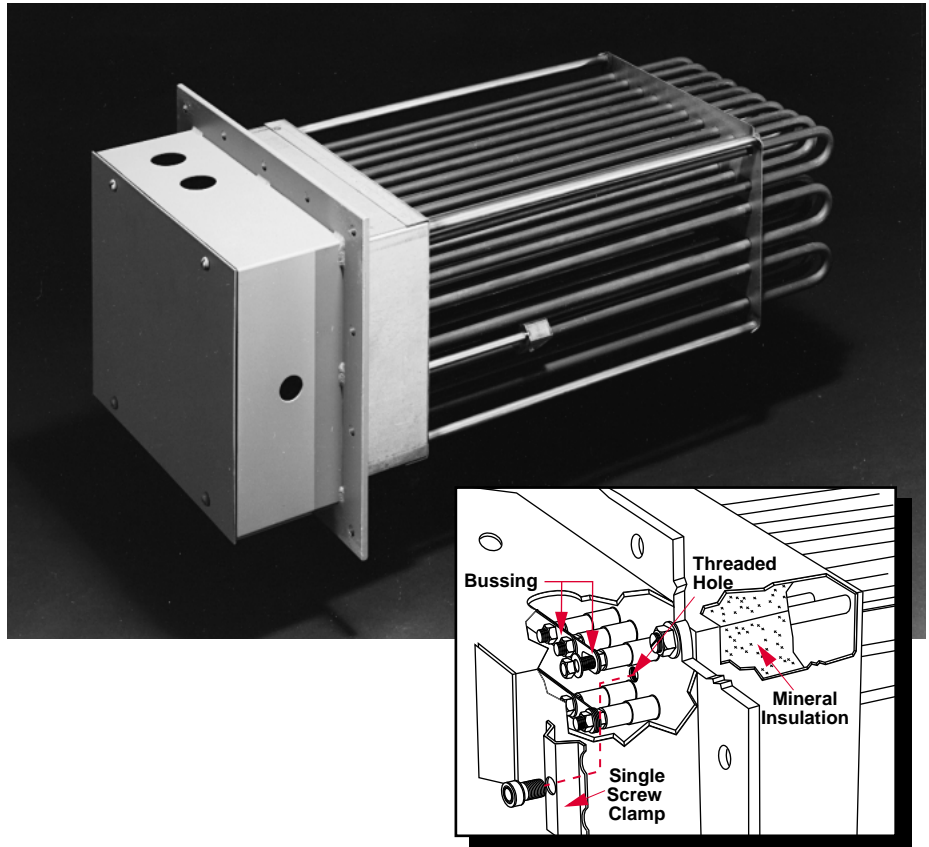

- **3½ inches (90 mm) thick mineral insulation** keeps wiring cooler and reduces heat loss.
- **Vented general purpose (NEMA 1) terminal enclosure** ensures cooler terminations.
- **A ¼ inch (6 mm) inside diameter thermowell** accepts an optional Type J or K thermocouple for accurate sheath temperature sensing.
- **Rigid stainless steel supports** prevent element sagging or deformation in various mounting positions.
- **A ¼ inch (6 mm) thick steel flange**, with ⅜ inch (10 mm) diameter mounting holes, easily bolts to the duct wall.
- **WATROD hairpins are repressed (recompacted)** after bending to assure MgO density that eliminates hot spots and electrical insulation voids.
- **Stock heaters feature 6, 12, 18, 24, 30, 36, 42, 48, 54, and 60 elements** to meet a wide variety of kW demands.
- **One or three phase voltages** to meet local power supplies.
- **Maximum 48 amps per circuit** complies with National Electrical Code (NEC).
- **Duct heaters with general purpose enclosures meet UL® and CSA component recognition** to 480 and 600V~(ac) maximum respectively—UL® and CSA file numbers are E52951 and 31388.

Incoloy® is a registered trademark of Special Metals Corporation.

UL® is a registered trademark of Underwriter's Laboratories, Inc.

# Tubular and Process Assemblies

## Duct Heaters

### Applications

- Drying ovens
- Autoclaves
- Furnaces
- Load banks
- Heat treating
- Reheating
- HVAC
- Paint drying

### Choosing a Duct Heater

The following English and metric graphs, shown on **pages 413 to 414**, will help you to select the correct duct heater. These graphs include: *Watt Density vs. Air Temperature/Velocity*, *Watt Density vs. Sheath Temperature and Pressure Drop vs. Air Velocity*. These graphs, with the quick formulas on this page, along with information specific to your application, will determine the correct duct heater specifications. However, if engineering assistance is needed, contact your Watlow representative.

### Required Application Information

- Desired outlet air temperature
- Inlet air temperature
- Delta T—the temperature difference between inlet and desired outlet temperature
- Air volume (CFM/CMM) measured at both inlet temperature and pressure
- Air velocity in feet per minute (FPM); meters per minute (MPM) which equals:
- Minimum duct heater wattage (kW). This can be determined by:

<b>English</b>	
$\text{FPM} = \frac{\text{CFM measured at standard conditions}}{\text{Duct cross section area at heater in ft}^2}$	
<b>Metric</b>	
$\text{MPM} = \frac{\text{CMM measured at normal conditions}}{\text{Duct cross section area at heater in m}^2}$	

<b>English</b>	
$\text{kW} = \frac{\text{CFM} \times \text{Delta T } (^{\circ}\text{F}) \times 1.1(\text{safety factor})}{3000}$	
<b>Metric</b>	
$\text{kW} = \frac{\text{CMM} \times \text{Delta T } (^{\circ}\text{C}) \times 1.1(\text{safety factor})}{48}$	

**Note:** The duct heater, or combination of duct heaters, used for the process should be equal to or exceed the minimum wattage calculation.

# Tubular and Process Assemblies

## Duct Heaters

### Watt Density vs. Air Temperature/Velocity

To decide watt density requirements, first determine the desired outlet air temperature and velocity in feet per minute. Then

follow the lines on the graph for velocity and process temperature to the watt density curve's intersecting point. This shows the recommended watt density based on a maximum

sheath temperature of 1400°F (760°C). **For longer heater life, lower watt densities should be chosen.**

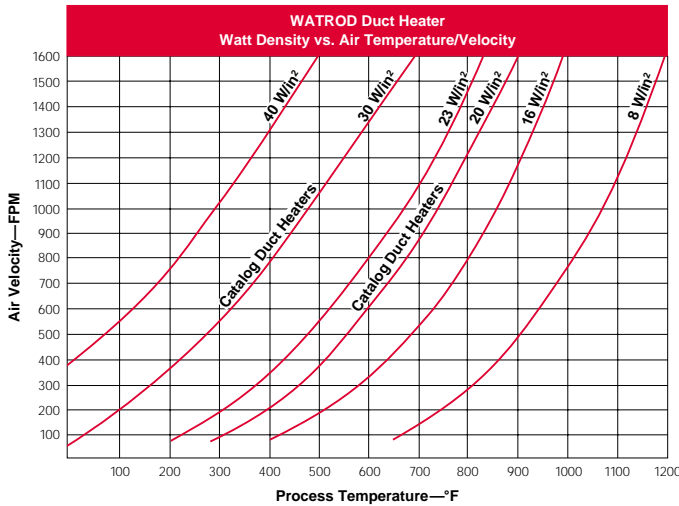

Estimated Sheath Temperature = 1400°F

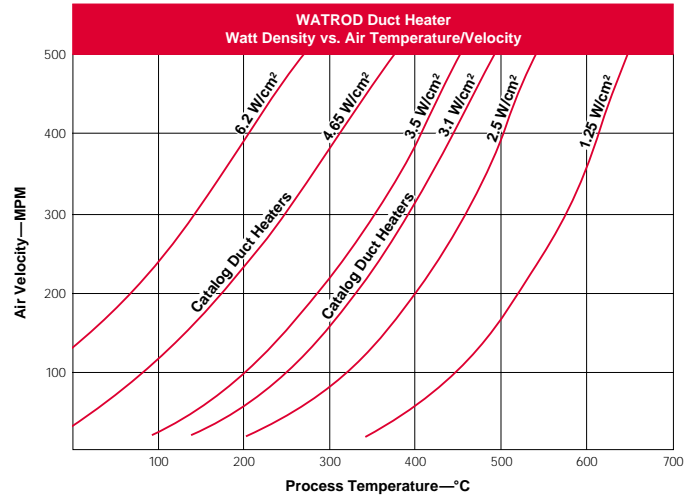

Estimated Sheath Temperature = 760°C

### Watt Density vs. Sheath Temperature

The *Watt Density vs. Sheath Temperature* graph shows the air velocity (FPM or MPM) required to operate a WATROD duct heater at

specific watt densities or sheath temperatures. Also depicted is the appropriate watt density vs. sheath temperature at a specified air flow.

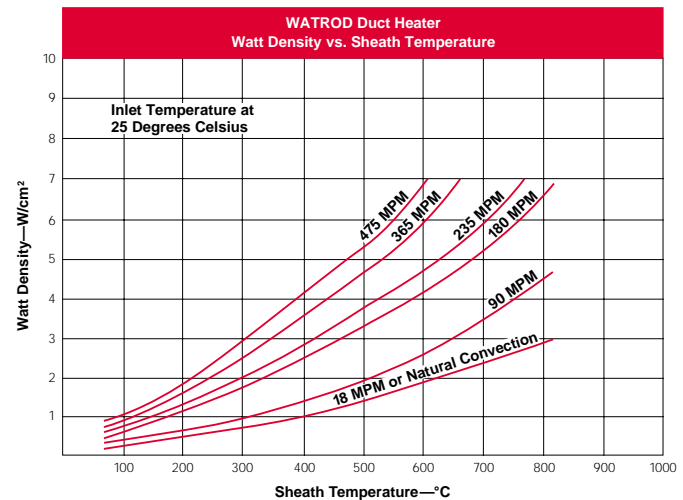
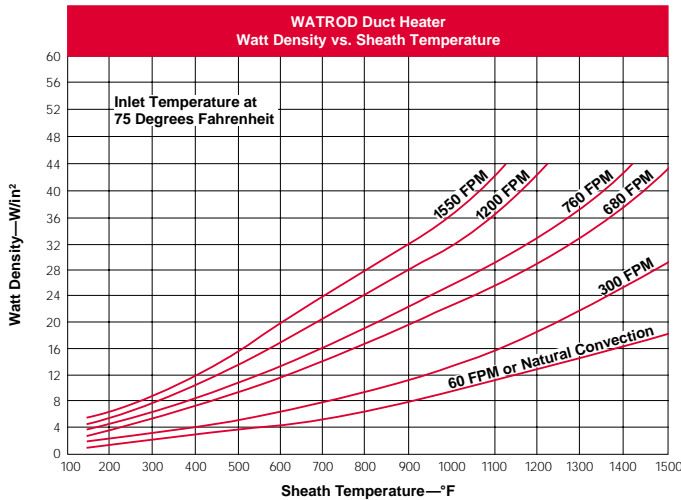

# Tubular and Process Assemblies

## Duct Heaters

### Pressure Drop vs. Air Velocity

The rate at which pressure drops through the duct heater is critical for properly sizing blowers and pumps. *The Pressure Drop vs. Air Velocity* graph gives recommended maximum velocities in feet per minute and meters per minute according to the air velocity and duct heater size.

To determine the pressure drop through the duct heater, follow the air velocity (FPM or MPM) over to the appropriate curve which identifies the duct heater size. Then, take the intersecting point down to the approximate pressure drop value.

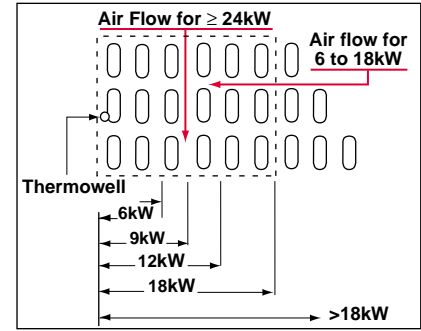

**Note:** Viewing from the element ends—the recommended air flow direction through element bundle changes at > 18kW.

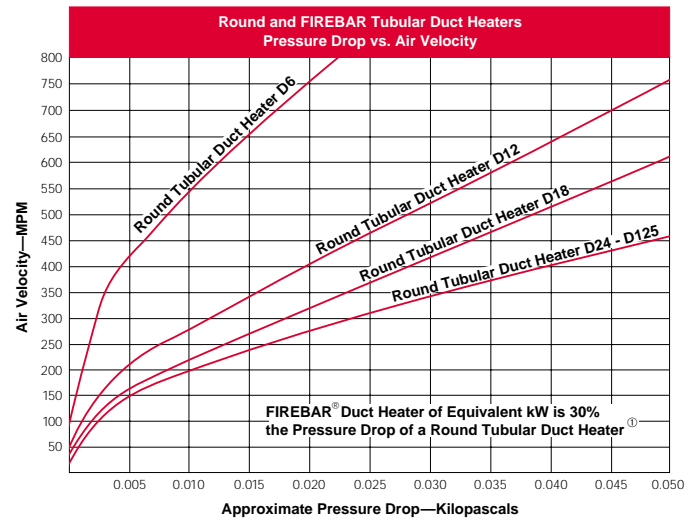
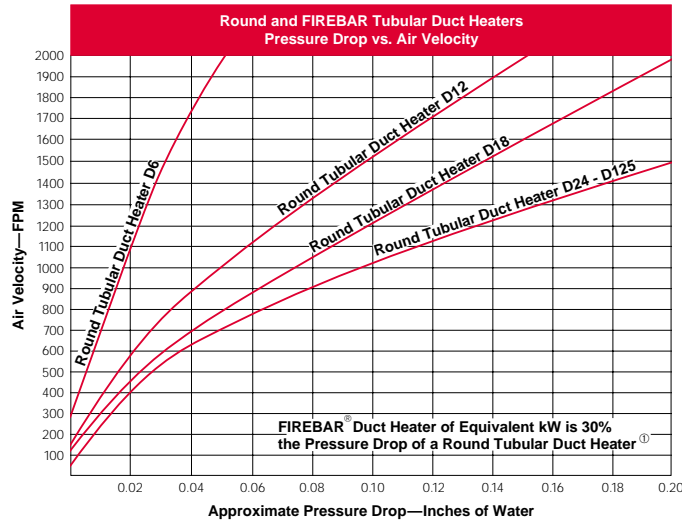

① FIREBAR® flat tubular element duct heaters can be custom designed and built when they enhance your application output or performance. Although duct heaters are not normally constructed with FIREBAR elements, we show the pressure drop reduction using FIREBAR as a distinct advantage.

### Options

#### Sheath Material

Watlow duct heaters can be made with element sheath materials other than Incoloy®.

Consult your Watlow representative for details and availability.

#### Wattages/Voltages

To meet specific application needs, voltage and wattage combinations outside stock product parameters are available.

For more information about this option, consult your Watlow representative.

## Tubular and Process Assemblies

### Duct Heaters

#### Options

Continued

#### Thermocouples

**Type J** or **K** thermocouples, inserted in the thermowell, accurately sense element sheath temperature for over-temperature conditions.

To sense process temperature, sensing element should be located down stream from the duct heater. This will eliminate incorrect sensing caused by radiant heat.

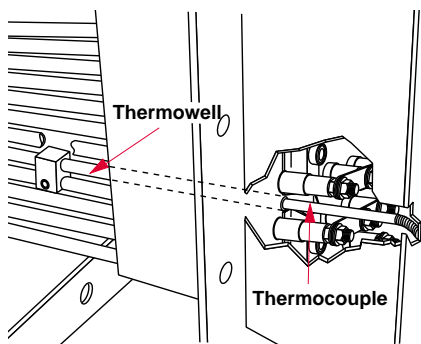

Duct heater thermowell holds thermocouple for sensing sheath temperature.

#### Terminal Enclosures

In addition to the standard, general purpose (NEMA 1) terminal enclosure, Watlow offers the following optional terminal enclosures to meet specific application requirements:

- Moisture resistant (NEMA 4)
- Stainless steel corrosion resistant (NEMA 4X—consult factory)
- Explosion resistant (NEMA 7—consult factory)
- Dust resistant (NEMA 12)

Thermocouples are supplied with 120 inch (3050 mm) leads (longer lead lengths available). Unless otherwise specified, thermocouples are supplied with temperature ranges detailed on the *Thermocouple Types* chart.

Using a thermocouple requires an appropriate temperature and power control. These must be purchased separately. Watlow offers a wide

variety of temperature and power controls to meet virtually all applications. Temperature controls can be configured to accept process variable inputs, too. Consult your Watlow representative for details.

To order a thermocouple, add the appropriate suffix letter to the duct heater's base code number, as indicated on the Build-a-Code chart on [page 418](#).

#### Thermocouple Types

ASTM Type	Conductor Characteristics		Recommended <sup>①</sup> Temperature Range	
	Positive	Negative	°F	(°C)
J	Iron (Magnetic)	Constantan (Non-magnetic)	0 to 1000	(-20 to 540)
K	Chromel® (Non-magnetic)	Alumel® (Magnetic)	0 to 2000	(-20 to 1100)

① **Type J** and **Type K** thermocouples are rated 32 to 1382°F and 32 to 2282°F (0-750°C and 0-1250°C), respectively. Watlow does not recommend exceeding temperature ranges shown on this chart for the tubular product line.

#### Application Hints

- Mount duct heaters horizontally to lower enclosure temperatures and promote unit life.
- Orient heating elements as per the air flow illustration on [page 414](#).
- Promote heater life by keeping sheath temperature below the 1400°F (760°C) maximum.
- Measure process temperature in the outlet stream, away from the heater.
- Maintain wiring integrity by keeping enclosure temperature below 400°F (205°C).
- Thermal cycling can cause terminations to loosen. Periodically check and tighten all electrical connections.
- Size power feeder wires in accordance with NEC and other applicable codes.
- Protect employees against electrical shock by properly grounding the unit per NEC specifications.

Alumel® and Chromel® are registered trademarks of Hoskins Manufacturing Company.

# Tubular and Process Assemblies

## Duct Heaters

- ① Stock heaters with six and 12 elements have one 1 inch NPT conduit opening. Stock heaters with 18, 24, 30 and 42 elements have two 1 inch NPT conduit openings. Stock heaters with 36, 48, 54 and 60 elements have two 1 inch NPT and two 1½ inch NPT conduit openings.
- ② All flanges are 12 inches wide.

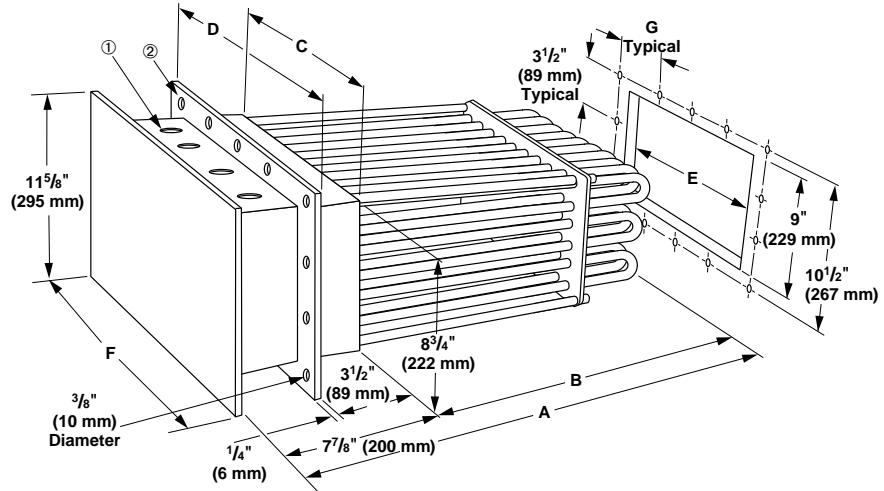

### Duct Heater Dimensions

Dimension Reference No.	Number of Elements	A Dimension in (mm)	B Dimension in (mm)	C Dimension in (mm)	D Dimension in (mm)	E Dimension in (mm)	F Dimension in (mm)	G Dimension in (mm)
1	6	27 7/8 (708)	20 (508)	2 3/4 (70)	6 1/2 (165)	3 (76)	5 3/4 (146)	2 1/2 (64)
2	12	27 7/8 (708)	20 (508)	4 3/4 (121)	8 1/2 (215)	5 (127)	7 3/4 (197)	3 1/2 (89)
3	18	27 7/8 (708)	20 (508)	6 3/4 (171)	10 1/2 (267)	7 (178)	9 3/4 (248)	3 1/2 (76)
4	24	27 7/8 (708)	20 (508)	8 3/4 (222)	12 1/2 (318)	9 (229)	11 3/4 (298)	2 3/4 (70)
5	30	27 7/8 (708)	20 (508)	10 3/4 (273)	14 1/2 (368)	11 (279)	13 3/4 (349)	3 3/4 (83)
6	36	27 7/8 (708)	20 (508)	12 3/4 (324)	16 1/2 (419)	13 (330)	15 3/4 (400)	3 3/4 (95)
7	42	27 7/8 (708)	20 (508)	14 3/4 (375)	18 1/2 (470)	15 (381)	17 3/4 (451)	4 1/4 (108)
8	48	27 7/8 (708)	20 (508)	16 3/4 (425)	20 1/2 (521)	17 (432)	19 3/4 (502)	4 3/4 (121)
9	54	27 7/8 (708)	20 (508)	18 3/4 (476)	22 1/2 (572)	19 (483)	21 3/4 (552)	5 1/4 (133)
10	60	27 7/8 (708)	20 (508)	20 3/4 (527)	24 1/2 (622)	21 (533)	23 3/4 (603)	5 3/4 (146)
11	60	32 7/8 (835)	25 (635)	20 3/4 (527)	24 1/2 (622)	21 (533)	23 3/4 (603)	5 3/4 (146)
12	60	40 7/8 (1026)	32 1/2 (826)	20 3/4 (527)	24 1/2 (622)	21 (533)	23 3/4 (603)	5 3/4 (146)
13	60	49 7/8 (1254)	41 1/2 (1054)	20 3/4 (527)	24 1/2 (622)	21 (533)	23 3/4 (603)	5 3/4 (146)

### 20 W/in<sup>2</sup> (3.1 W/cm<sup>2</sup>)

kW	Dimension Reference No.	Number of Elements	Code No.								Est. Ship.	
			240V~(ac) 1-Phase	# of Circ.	240V~(ac) 3-Phase	# of Circ.	480V~(ac) 1-Phase	# of Circ.	480V~(ac) 3-Phase	# of Circ.	Weight lbs (kg)	
6	1	6	D6S10	1	D6S3	1	D6S11	1	D6S5	1	50 (23)	
12	2	12	D12S10	1	D12S3	1	D12S11	1	D12S5	1	55 (25)	
18	3	18	D18S10	2	D18S3	1	D18S11	1	D18S5	1	65 (30)	
24	4	24	D24S10	2	D24S3	2	D24S11	1	D24S5	1	95 (43)	
30	5	30			D30S3	2	D30S11	2	D30S5	1	120 (55)	
36	6	36			D36S3	2	D36S11	2	D36S5	1	135 (62)	
42	7	42			D42S3	2	D42S11	2	D42S5	2	155 (71)	
48	8	48			D48S3	4	D48S11	2	D48S5	2	195 (89)	
54	9	54			D54S3	3	D54S11	3	D54S5	2	205 (93)	
60	10	60			D60S3	4	D60S11	4	D60S5	2	235 (107)	
75	11	60			D75S3②	4	D75S11	4	D75S5	2	260 (118)	
100	12	60							D100S5②	4	290 (132)	
125	13	60							D125S5②	4	310 (141)	

All duct heaters are Assembly Stock unless otherwise noted. ② Standard

#### Availability

**Assembly Stock:** Three to five working days

**Standard:** 10 working days

Truck Shipment only

# Tubular and Process Assemblies

## Duct Heaters

30 W/in<sup>2</sup> (4.7 W/cm<sup>2</sup>)

kW	Dimension Reference No.	Number of Elements	Code No.								Est. Ship.	
			240V~(ac) 1-Phase	# of Circ.	240V~(ac) 3-Phase	# of Circ.	480V~(ac) 1-Phase	# of Circ.	480V~(ac) 3-Phase	# of Circ.	Weight lbs	(kg)
9	1	6	<b>D6SX10</b>	1	<b>D6SX3</b>	1	<b>D6SX11</b>	1	<b>D6SX5</b>	1	50 (23)	
18	2	12	<b>D12SX10</b>	2	<b>D12SX3</b>	1	<b>D12SX11</b>	1	<b>D12SX5</b>	1	55 (25)	
27	3	18	<b>D18SX10</b>	3	<b>D18SX3</b>	2	<b>D18SX11</b>	2	<b>D18SX5</b>	1	65 (30)	
36	4	24	<b>D24SX10</b>	4	<b>D24SX3</b>	2	<b>D24SX11</b>	2	<b>D24SX5</b>	1	95 (43)	
45	5	30			<b>D30SX3</b>	5	<b>D30SX11</b>	2	<b>D30SX5</b>	2	120 (55)	
54	6	36			<b>D36SX3</b>	3	<b>D36SX11</b>	3	<b>D36SX5</b>	2	135 (62)	
63	7	42			<b>D42SX3</b>	7	<b>D42SX11</b>	3	<b>D42SX5</b>	2	155 (71)	
72	8	48			<b>D48SX3</b>	4	<b>D48SX11</b>	4	<b>D48SX5</b>	2	195 (89)	
81	9	54			<b>D54SX3</b>	6	<b>D54SX11</b>	6	<b>D54SX5</b>	3	205 (93)	
90	10	60			<b>D60SX3</b>	5	<b>D60SX11</b>	4	<b>D60SX5</b>	4	235 (107)	
115	11	60			<b>D75SX3</b> ②	10	<b>D75SX11</b>	5	<b>D75SX5</b>	4	260 (118)	
150	12	60							<b>D100SX5</b> ②	4	290 (132)	
190	13	60							<b>D125SX5</b> ②	5	310 (141)	

### Replacement Elements

#### Replacement Elements

Replaceable heating elements provide easy field service and reduce downtime. Element change-out is made simple by a single screw clamp.

To order replacement elements, specify the **replacement element code number** (from the table) that corresponds to the original Watlow duct heater code number. Then specify **quantity**.

Original Duct Heater Code Numbers	Replacement Element		A Dimension in (mm)	Replacement Element Code No.	Availability	Est. Net Weight	
	Volts	Watts				lbs	(kg)
<b>20 W/in<sup>2</sup> (3.1 W/cm<sup>2</sup>)</b>							
<b>D6S3 to D60S3</b>	240	1000	27% (708)	<b>D6240</b>	Stock	1.0	(0.5)
<b>D6S5 to D60S5</b>	480	1000	27% (708)	<b>D6480</b>	Stock	1.0	(0.5)
<b>D75S3</b>	240	1250	32% (835)	<b>D75240</b>	Standard	1.0	(0.5)
<b>D75S5</b>	480	1250	32% (835)	<b>D75480</b>	Stock	1.0	(0.5)
<b>D100S5</b>	480	1667	40% (1026)	<b>D100480</b>	Stock	1.4	(0.7)
<b>D125S5</b>	480	2083	49% (1254)	<b>D125480</b>	Stock	1.7	(0.8)
<b>30 W/in<sup>2</sup> (4.7 W/cm<sup>2</sup>)</b>							
<b>D6SX3 to D60SX3</b>	240	1500	27% (708)	<b>D6X240</b>	Stock	1.0	(0.5)
<b>D6SX5 to D60SX5</b>	480	1500	27% (708)	<b>D6X480</b>	Stock	1.0	(0.5)
<b>D75SX3</b>	240	1917	32% (835)	<b>D75X240</b>	Standard	1.0	(0.5)
<b>D75SX5</b>	480	1917	32% (835)	<b>D75X480</b>	Stock	1.0	(0.5)
<b>D100SX5</b>	480	2500	40% (1026)	<b>D100X480</b>	Stock	1.4	(0.7)
<b>D125SX5</b>	480	3167	49% (1254)	<b>D125X480</b>	Stock	1.7	(0.8)

All duct heaters are Assembly Stock unless otherwise noted.

#### Availability

**Assembly Stock:** Three to five working days

**Standard:** 10 working days

Truck Shipment only

② Standard

## Duct Heaters

### Build-a-Code

**Duct Heater Base Code Number** \_\_\_\_\_

(Includes general purpose (NEMA 1) enclosure)

**Terminal Enclosure Type** \_\_\_\_\_

**W** = Moisture resistant (NEMA 4)

**D** = Dust resistant (NEMA 12)

**Thermocouple Sensor** \_\_\_\_\_

**J** = Type J

**K** = Type K

### How to Order

To order stock duct heaters, please specify:

- Watlow code number
- Volts/watts
- Phase
- Options
- Quantity

If our stock units do not meet your application needs, Watlow can provide a made-to-order unit. For **made-to-order** units please consult your Watlow representative and provide the following information:

- Application (inlet and outlet air temperature, CFM/CMM, duct size and mounting orientation)
- Volts/watts
- Phase
- Number of circuits
- Watt density
- Number of heating elements
- Sheath material
- Element ('B' dimension) length
- Mounting flange material and mounting hole layout
- Insulation thickness and material
- Terminal enclosure type
- Options
- Quantity

### Availability

**Assembly Stock:** Three to five working days

**Modified Stock**<sup>①</sup>: Five to seven working days

**Standard:** 10 working days

**Made-to-Order:** Five to seven weeks

### Replacement Elements Only

**Stock:** Same day shipment

**Standard:** 10 working days

**Made-to-Order:** Four weeks

Options, complexity and quantity may affect availability and lead times. Consult factory.

<sup>①</sup> Stock or Assembly Stock units with catalog options.

## Tubular and Process Assemblies

### Modular Duct Heater

Watlow has developed a new line of process air heaters that offer improved performance and increased versatility in medium to low temperature applications.

The new duct heaters are modular and consist of two parts. The first is a 6kW heater available in either 240 or 480 volts, single or three phase.

The second part of the heater consists of the electrical housing that protects each module's termination area and a main flange that bolts into the user's ductwork. The heater modules are installed in the housing and main flange via rectangular slots in the main flange. The range of modules that can be accommodated in various duct heater assemblies, range from 1-10 modules. A range of 6-60kW, in 6kW increments is achieved.

The new design of the modular duct heater offers increased reliability. The individual modules are removable through the housing of the assembly, which eliminates the need to pull the complete heater from the ductwork. This reduces downtime and costs because the heating elements can be replaced individually.

Performance improvements include quicker response time and reduced infiltration from the air stream being heated into the electrical enclosure.

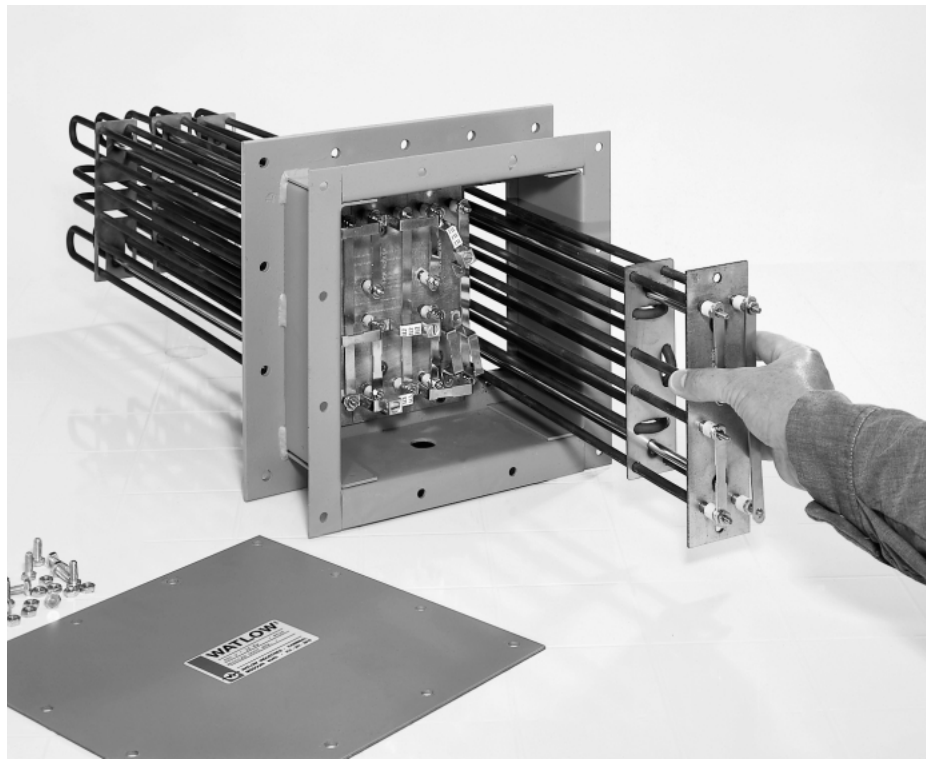

#### Features and Benefits

- **Individual modules removable through housing** reduces downtime for replacement of module.
- **27 percent reduction in heat-up time as compared to traditional 0.430 inch diameter duct heater elements** result in a faster response time.
- **Smaller diameter elements (0.315 inch)** result in a 25 percent lower energy usage on initial heat-up.
- **31 percent lighter weight than traditional tubular duct heaters** reduces shipping costs and increases worker safety.
- **Greater free cross sectional area** results in lower pressure drop.
- **Improved seal between element and electrical housing** results in lower electrical housing temperature.
- **Flexible module wiring** allows user to sequentially stage modules.

#### Applications

- Low temperature ovens
- Parts drying
- Semiconductor clean room environmental heating
- Plastic curing
- Load banks
- Heated air knives
- Food dehydration
- Heat shrink tunnels

# Tubular and Process Assemblies

## Modular Duct Heater

### Velocity vs. Process Temperature

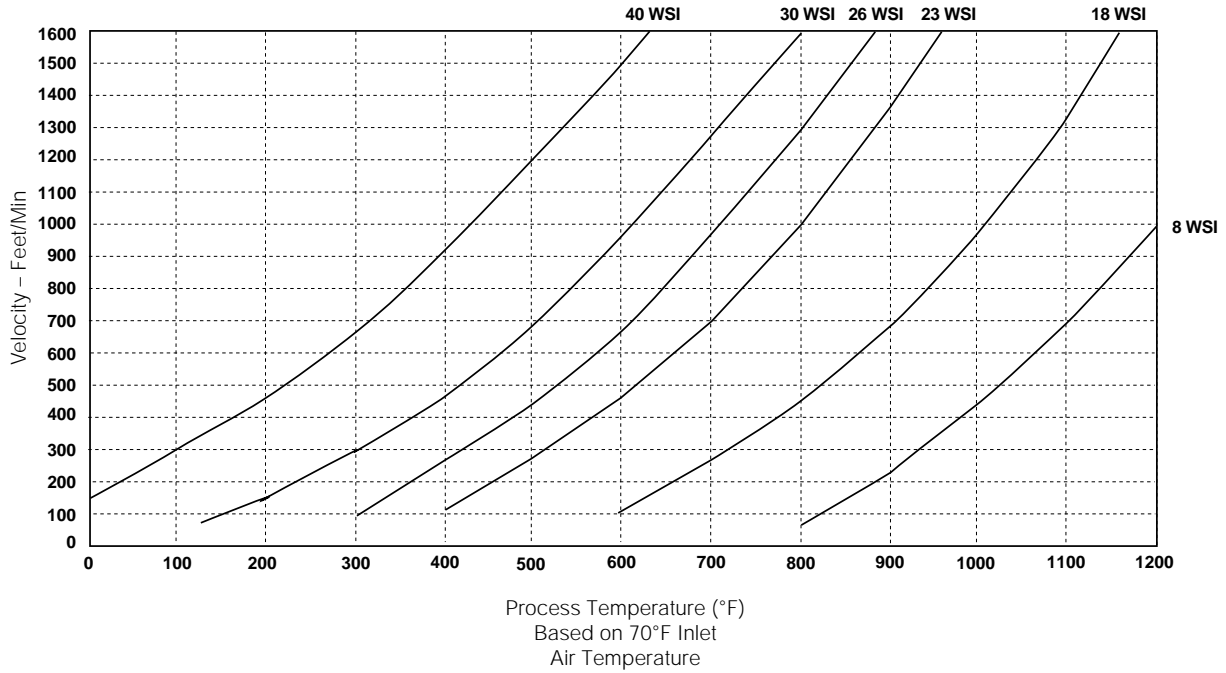

### Watt Density vs. Sheath Temperature

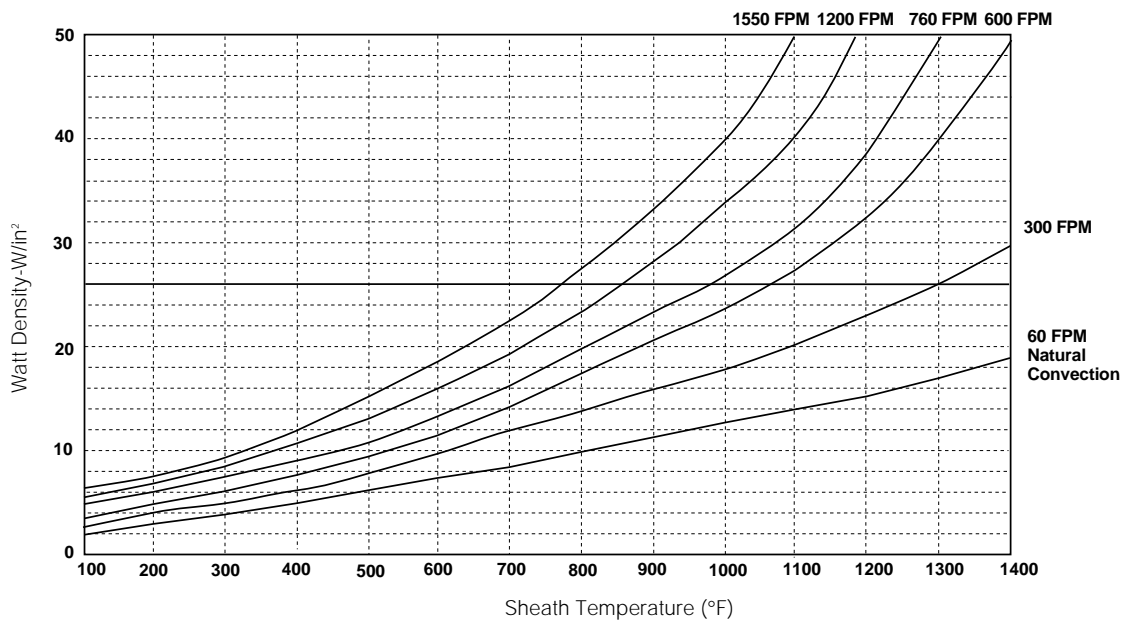

# Tubular and Process Assemblies

## Modular Duct Heater

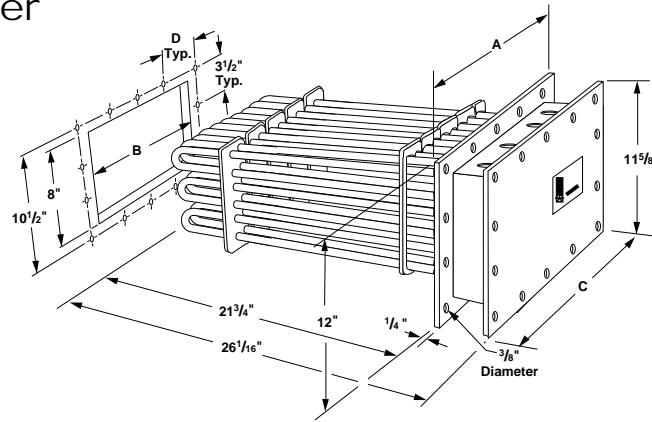

**Application: Air Heating – Maximum outlet temperature – 750°F**

Watt Density W/in <sup>2</sup>	kW	Volts	Phase	No. of Circuits	No. of Modules	Est. Shipping Wt. lbs	Availability	Code No.	Dimensions in.			
									A	B	C	D
26	6	240	1	1	1	35	Assy. Stk.	MDH6S10	6.50	2.50	5.75	2.50
26	6	240	3	1	1	35	Assy. Stk.	MDH6S3	6.50	2.50	5.75	2.50
26	6	480	1	1	1	35	Assy. Stk.	MDH6S11	6.50	2.50	5.75	2.50
26	6	480	3	1	1	35	Assy. Stk.	MDH6S5	6.50	2.50	5.75	2.50
26	12	240	1	2	2	39	Assy. Stk.	MDH12S10	8.50	4.75	7.75	3.50
26	12	240	3	1	2	39	Assy. Stk.	MDH12S3	8.50	4.75	7.75	3.50
26	12	480	1	1	2	39	Assy. Stk.	MDH12S11	8.50	4.75	7.75	3.50
26	12	480	3	1	2	39	Assy. Stk.	MDH12S5	8.50	4.75	7.75	3.50
26	18	240	1	3	3	46	Assy. Stk.	MDH18S10	10.50	7.00	9.75	3.00
26	18	240	3	1	3	46	Assy. Stk.	MDH18S3	10.50	7.00	9.75	3.00
26	18	480	1	1	3	46	Assy. Stk.	MDH18S11	10.50	7.00	9.75	3.00
26	18	480	3	1	3	46	Assy. Stk.	MDH18S5	10.50	7.00	9.75	3.00
26	24	240	1	4	4	67	Assy. Stk.	MDH24S10	12.50	9.25	11.75	2.75
26	24	240	3	2	4	67	Assy. Stk.	MDH24S3	12.50	9.25	11.75	2.75
26	24	480	1	2	4	67	Assy. Stk.	MDH24S11	12.50	9.25	11.75	2.75
26	24	480	3	1	4	67	Assy. Stk.	MDH24S5	12.50	9.25	11.75	2.75
26	30	240	3	2	5	84	Assy. Stk.	MDH30S3	15.75	11.50	15.00	3.56
26	30	480	1	2	5	84	Assy. Stk.	MDH30S11	15.75	11.50	15.00	3.56
26	30	480	3	1	5	84	Assy. Stk.	MDH30S5	15.75	11.50	15.00	3.56
26	36	240	3	2	6	95	Assy. Stk.	MDH36S3	18.00	13.75	17.25	4.13
26	36	480	1	2	6	95	Assy. Stk.	MDH36S11	18.00	13.75	17.25	4.13
26	36	480	3	1	6	95	Assy. Stk.	MDH36S5	18.00	13.75	17.25	4.13
26	42	240	3	3	7	109	Assy. Stk.	MDH42S3	20.25	16.00	19.50	4.69
26	42	480	1	3	7	109	Assy. Stk.	MDH42S11	20.25	16.00	19.50	4.69
26	42	480	3	2	7	109	Assy. Stk.	MDH42S5	20.25	16.00	19.50	4.69
26	48	240	3	4	8	137	Assy. Stk.	MDH48S3	22.50	18.25	21.75	5.25
26	48	480	1	3	8	137	Assy. Stk.	MDH48S11	22.50	18.25	21.75	5.25
26	48	480	3	2	8	137	Assy. Stk.	MDH48S5	22.50	18.25	21.75	5.25
26	54	240	3	3	9	144	Assy. Stk.	MDH54S3	24.75	20.50	24.00	5.81
26	54	480	1	3	9	144	Assy. Stk.	MDH54S11	24.75	20.50	24.00	5.81
26	54	480	3	2	9	144	Assy. Stk.	MDH54S5	24.75	20.50	24.00	5.81
26	60	240	3	4	10	165	Assy. Stk.	MDH60S3	27.00	22.75	26.25	6.38
26	60	480	1	4	10	165	Assy. Stk.	MDH60S11	27.00	22.75	26.25	6.38
26	60	480	3	2	10	165	Assy. Stk.	MDH60S5	27.00	22.75	26.25	6.38

Duct Heaters

Options include individual modules with optional NEMA1 housing, high temperature thermocouple kit and blank flange modules.

Modular duct heaters with **1** and **2** modules have conduit openings for **1-1** inch NPT fitting.

Modular duct heaters with **3,4,5,** and **7** modules have conduit openings for **2-1** inch NPT fittings.

Modular duct heaters with **6,8,9,** and **10** modules have conduit openings for **2-1 ¼** inch NPT and **2-1** inch NPT fittings.

# Tubular and Process Assemblies

## Modular Duct Heater

### Individual Module Dimensions

#### Specifications

- Module rating - 240 or 480V~(ac), 6kW, three phase or one phase
- Watt Density - 26 W/in<sup>2</sup>
- Elements - 0.315 inch dia. Incoloy® elements
- High-limit thermocouple installed by drilling premarked hole in flange
- 6-60kW range when mounted in duct heater assembly

#### Application Information

- Maximum sheath temperature = 1200°F
- Maximum outlet temperature = 750°F

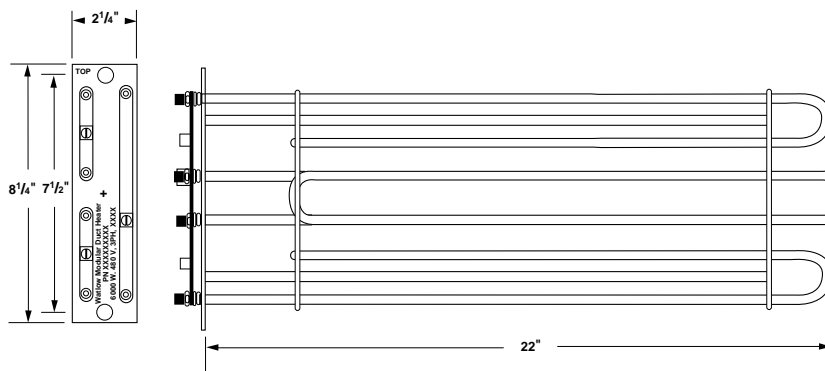

#### Options

##### Terminal Enclosures

Terminal enclosures are available in NEMA 1 and 4 configurations.

##### High-Limit Thermocouples

High-limit thermocouples can be supplied on specified modules or shipped as a kit. Available thermocouples are Types J and K.

##### Blank Module Covers

Module covers are available for covering blank slots on the main flange. This allows for adding heater module at a later time to allow higher wattage outputs.

Watlow Code Number	Description
<b>Replacement Modules</b>	
<b>M63</b>	6kW, 240 volts, 3 phase
<b>M610</b>	6kW, 240 volts, 1 phase
<b>M65</b>	6kW, 480 volts, 3 phase
<b>M611</b>	6kW, 480 volts, 1 phase
<b>High Limit Thermocouple Kits</b>	
<b>MTCJ</b>	Type J (0-1000°F)
<b>MTCK</b>	Type K (0-2000°F)
<b>Blank Module Covers</b>	
<b>MBLK</b>	Cover slots in main flange

#### Availability

- **Assembly Stock:** Three to five working days
  - **Made-to-Order:** Eight weeks
- Consult factory for more details.

## Tubular and Process Assemblies

### Thermostats and Accessories

Thermostats regulate temperature in non-critical applications. They sense temperature, within a preset range and cycle heaters on and off to maintain the set point.

Thermostats may be mounted inside a terminal enclosure or remote mounted (separate from the heater assembly). If using a remote mounted thermostat, be sure to order sufficient capillary tube length to permit installation.

All Watlow thermostats are normally closed circuit and either single pole, single throw (SPST) or double pole, single throw (DPST). They can be used with or without an enclosure.

Thermostat selection should be based on temperature range, capillary tube length and sensor bulb size (diameter/length).

#### Remote Mount Thermostat Assemblies

Remote mounted thermostat assemblies can be supplied with the following enclosures:

- General purpose (NEMA 1)
- Moisture resistant (NEMA 4)
- Explosion resistant (NEMA 7)
- Explosion/moisture resistant (NEMA 7/4)
- Dust resistant (NEMA 12)

#### Pilot Light

An optional pilot light gives visual indication whether the power supplied to the heating element(s) is on or off.

To order, please specify suffix code **PL11**.

#### Thermostat Conversion Kits

Kits are available to convert a heater's general purpose (NEMA 1) terminal enclosure to accept either a single or double pole thermostat.

### Thermostats with Enclosures

#### NEMA 1 Single and Double Pole

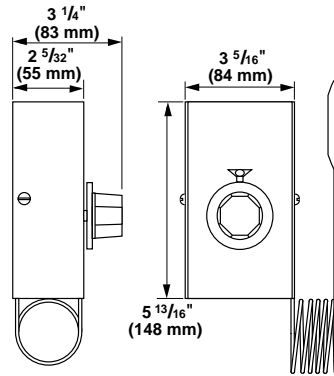

#### NEMA 4 and 12 Single Pole

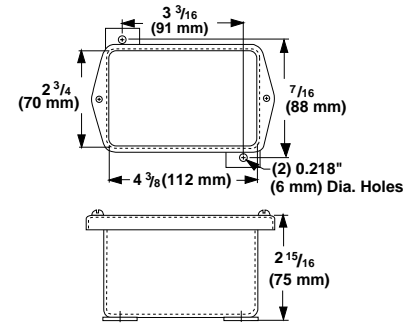

#### NEMA 7 Single Pole

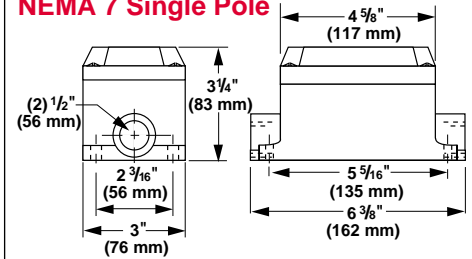

#### NEMA 4 and 12 Double Pole

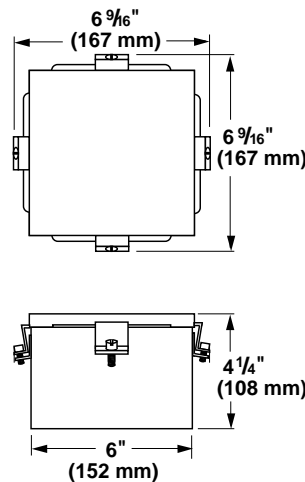

#### NEMA 7 Double Pole

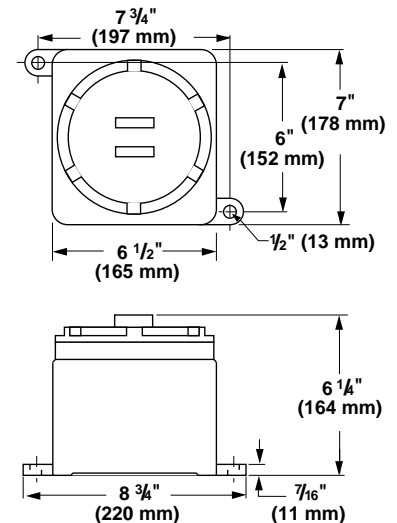

The kit contains all the necessary parts to change out the existing terminal enclosure cover and mount the thermostat inside. These are **hardware and wiring kits** only.

**Single pole conversion kit** covers 1, 1 1/4, 2 and 2 1/2 inch NPT screw plugs. To order, specify code **K492-000-35-(thermostat type)**.

**Double pole conversion kit** covers 2 and 2 1/2 inch NPT screw plugs. To order, specify code **K492-000-34-(thermostat type)**.

#### Celsius Dial Scale

Thermostats are shipped with Fahrenheit (°F) dial scales. If your application requires a Celsius (°C) scale, order the optional dial face. To order, specify code **CD**. Scale will match thermostat temperature range.

# Tubular and Process Assemblies

## Thermostats and Accessories

### Application Hints

- Locate the thermostat where ambient temperatures do not exceed 150°F (65°C).
- Mount the thermostat in an enclosure that is compatible with the surrounding environment.
- Immerse the entire sensing bulb in the media being heated.
- Make sure the sensing bulb is mounted away from the heating element(s) to negate any undue influence on the sensing bulb's temperature "reading."
- Keep the capillary tube insulated from electrical connections.
- Do not use a thermostat for high-accuracy temperature sensing. Use an appropriate thermocouple, RTD or thermistor and temperature control.
- Do not use thermostats as a primary power switching device. Use a disconnect switch or

circuit breaker to cut power when servicing.

- Interconnect the thermostat to the heater only if:
  - The heater has one circuit
  - The heater's ampere draw is lower than the thermostat's rated ampacity at prescribed voltage.
- Interconnect either a single or double pole thermostat with a single-phase heater when the supply voltage does not exceed 277V~(ac) for SPST or 480V~(ac) for DPST.
- Only interconnect three-phase delta heaters to DPST thermostats.
- Use a single pole thermostat for pilot duty where the thermostat is not interconnected with the heater, or heater exceeds the volt/amp rating.

### Warning

Do not use thermostats for high-limit sheath protection. Thermostats fail in a closed circuit mode and will not cut power to the heaters. Limit control should be provided by an isolated, redundant sensor and control system of the appropriate type, design and installation.

Thermostats are precalibrated at the factory. No adjustment, other than selecting the desired operating temperature, is required. All wiring should be performed by qualified personnel and comply with the National Electrical Code and other applicable state and local codes.

To help assure you select the correct thermostat, as well as install and wire it properly, we have put together a few helpful hints. Schematics are provided for interconnecting thermostats to single- and three-phase heaters.

### Pilot Duty Wiring

#### SPST, 1-phase

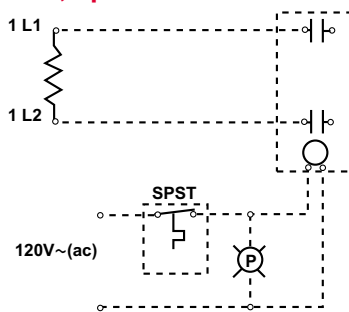

#### SPST, 3-phase delta

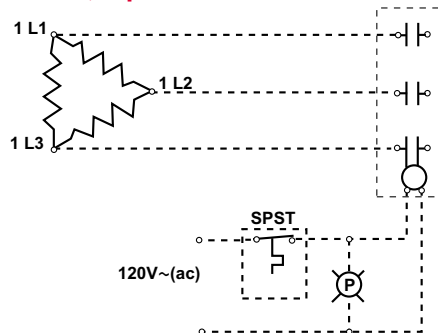

#### SPST, 3-phase wye

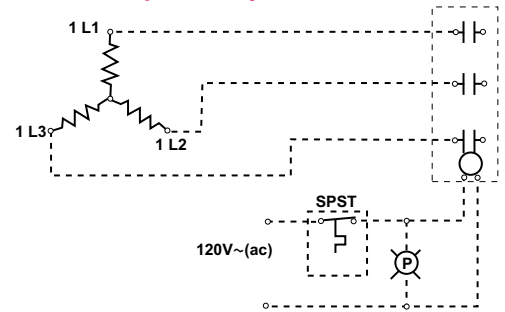

### Interconnected Wiring

#### SPST, 1-phase

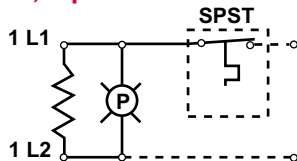

#### DPST, 1-phase

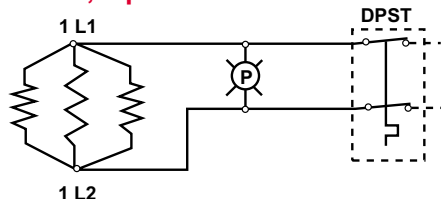

#### DPST, 3-phase delta

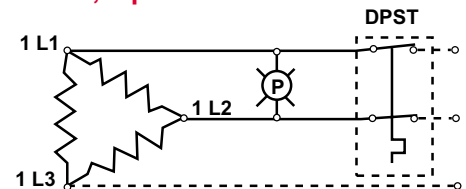

# Tubular and Process Assemblies

F.O.B.: Hannibal, Missouri

Thermostats Accessories

## Thermostats and Accessories

### Thermostat

Control Mode	Type	Temperature Range		Differential °F (°C)	Ampacity @ Line Voltage				Bulb Diameter inch (mm)	Bulb Length inch (mm)	Capillary Length inch (mm)	Terminal Type	Code No.	Est. Net Weight lbs (kg)
		°F	(°C)		120	240	277	480						
On-off Temp Control	Single Pole	30-110	(0-40)	8 (0)	25	25	22	—	0.250 (6)	4 ¼ (121)	18 (455)	#12 AWG	<b>1</b>	1 (0.4)
		30-250	(0-120)	15 (8)	25	25	22	—	0.250 (6)	3 ¼ (85)	18 (455)		<b>2</b>	1 (0.4)
	Single Throw (SPST)	30-250	(0-120)	15 (8)	25	25	22	—	0.250 (6)	3 ¼ (85)	84 (2135)	Stranded Leads	<b>2A</b>	1 (0.4)
		175-550	(80-290)	26 (14)	25	25	22	—	0.250 (6)	3 ¾ (85)	18 (455)		<b>3</b>	1 (0.4)
		175-550	(80-290)	26 (14)	25	25	22	—	0.250 (6)	2 ¾ (70)	84 (2135)		<b>3A</b>	1 (0.4)
		300-700	(150-350)	12 (7)	25	25	—	—	0.375 (10)	3 ¾ (95)	60 (1525)		<b>10</b>	1 (0.4)
	Double Pole	60-160	(15-70)	19 (10)	30	30	30	20	0.250 (6)	4 ¾ (110)	14 (355)	#10-32 Screw Lug	<b>12A</b>	1 (0.4)
		30-110	(0-40)	12 (7)	30	30	30	21	0.375 (10)	6 ¼ (160)	36 (915)		<b>4</b>	2 (0.9)
		60-250	(15-120)	12 (7)	30	30	30	21	0.375 (10)	4 ½ (115)	48 (1220)		<b>5</b>	2 (0.9)
		60-250	(15-120)	12 (7)	30	30	30	21	0.250 (6)	6 ½ (165)	48 (1220)		<b>5A</b>	2 (0.9)
100-550		(40-290)	22 (12)	30	30	30	21	0.375 (10)	3 ¾ (100)	48 (1220)	<b>7</b>		2 (0.9)	
100-550		(40-290)	22 (12)	30	30	30	21	0.250 (6)	7 ⅞ (179)	48 (1220)	<b>7A</b>		2 (0.9)	
On-off with	(DPST)	60-250	(15-120)	12 (7)	30	30	30	—	0.250 (6)	6 ½ (165)	48 (1220)	#10-32 Screw Lug	<b>8</b>	2 (0.9)
		100-550	(40-290)	22 (12)	30	30	30	—	0.188 (8)	12 (305)	48 (1220)		<b>9</b>	2 (0.9)
Manual Reset	(SPST)	350 <sup>Ⓛ</sup>	(180)	—	30	30	20	—	0.250 (6)	3 ½ (90)	36 (915)	#10-32 Screw Lug	<b>11</b>	1 (0.4)

Ⓛ Fixed temperature setting

### Availability

**Stock:** Same day shipment

### How to Order

**Thermostat Code Number** \_\_\_\_\_

(See stock chart above)

**Enclosure (Remote Mount Only)** \_\_\_\_\_

- S** = General purpose (NEMA 1)
- W** = Moisture resistant (NEMA 4)
- E** = Explosion resistant (NEMA 7)
- E/W** = Explosion/moisture resistant (NEMA 7/4)
- D** = Dust resistant (NEMA 12)

**Options** \_\_\_\_\_

- CD** = Celsius dial scale
- CB** = Chrome bezel
- LTB** = Liquid-tight brass fitting (¾"-18 NPT)
- PL11** = Pilot Light

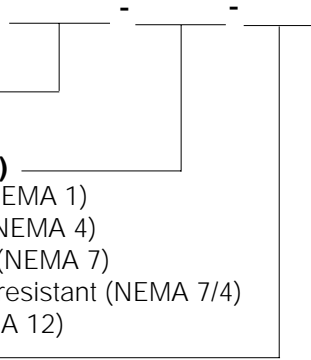

Cross-Reference For Replacement Thermostat	Order With This Number
202-0-21-1 (small knob)	1
202-0-21-2 (small knob)	202-0-21-2MB
202-0-21-4	2
202-0-21-5	2A
202-0-21-3	3
202-0-21-8 (small knob)	202-0-21-8M
202-0-21-6	3A
202-0-4-2	4
202-0-4-6	5
202-0-4-17	5A
202-0-4-5	7
202-0-4-16	7A
202-0-3-1	8
202-0-3-3	9
202-0-1-13	10
202-0-29-2	11
202-0-41-2 (small knob)	12A

If you only have the thermostat code number use this cross-reference chart.

### Availability

#### Thermostats

**Stock:** Same day shipment

#### Remote Mount Thermostats

**Stock:** Same day shipment

**Assembly Stock:** Three to five working days

**Modified Stock<sup>Ⓜ</sup>:** Three to five working days

**Standard:** Eight to 10 working days

Options, complexity and quantity may affect availability and lead times. Consult factory.

<sup>Ⓜ</sup> Stock or Assembly Stock units with catalog options.

# Tubular and Process Assemblies

F.O.B.: Hannibal, Missouri

## Thermostats and Accessories

### Low Liquid Level Sensor

The Watlow low liquid level sensor can protect a heating system by sensing when a liquid drops below a predetermined level. This is accomplished by locating the sensor at the minimum desired liquid level in the tank or vessel. The sensor's ASTM Type J thermocouple output can be connected to a variety of controls, alarms and limit protection devices.

To provide an additional margin of protection, the Type J thermocouple makes this low liquid level sensor respond considerably faster than conventional capillary bulb thermostats.

To order, specify code number **BCN5J1SJ**.

#### Application Hints

- Only use sensor in **non-flammable** liquids that are compatible with the Incoloy® sheath and 304 stainless steel screw plug.

- Application should tolerate sheath temperature at limit set point.
- The time delay between the low liquid level condition on-set, and the sensor's ability to signal the control device should be adequate to protect the heater(s). See *Installation and Maintenance Instructions* for details.

#### Controller Recommendation

- Use Watlow Safety Limit Temperature Control Series 142 (Code number **142A-3605-1300**). This controller features compact sub-panel mounting and is sealed against ambient environment. UL® recognized for limit protection (UL 991, "Tests For Safety-Related Controls Employing Solid State Devices").

Controller supplied by Watlow's Winona, Minnesota facility.

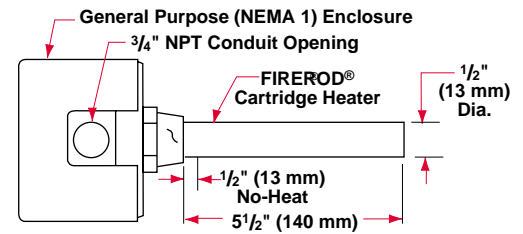

#### Specifications

**Screw plug:** 1" NPT

**Plug material:** 304 stainless steel

**Sheath material:** Incoloy®

**Watt density:** 13 W/in<sup>2</sup> (2 W/cm<sup>2</sup>)

**Watts:** 100

**Volts:** 120V~(ac)

**Immersed length:** 5 1/2 inch (140 mm)

**Thermocouple:** ASTM Type J

**Est. ship. wt.:** 2 lbs (1 kg)

#### Availability

**Stock:** Same day shipment

**Modified Stock**®: Five to seven working days

**Made-to-Order:** Four to six weeks

Options, complexity and quantity may affect availability and lead times. Consult factory.

® Stock units with catalog options.

### Protective Wells

Protective wells isolate and protect thermostat bulbs and other temperature sensors (thermocouples, RTDs or thermistors). They allow inserting the sensing element sufficiently into the media being heated without being damaged.

Steel or stainless steel protective wells are available in three lengths. They are supplied with 1/2 inch NPT mounting and 3/8 inch-18 NPT internal thread for mating to a liquid-tight bushing (LTB).

All units are stock. To order, specify the appropriate code number from the stock table.



#### Protective Wells

Plug and Thermowell Material	Immersed B Dimension inch (mm)	Code No.	Est. Ship. Weight lb (kg)
Steel	12 (305)	<b>PWS12</b>	1 (0.5)
	24 (610)	<b>PWS24</b>	2 (1.0)
	36 (915)	<b>PWS36</b>	2 (1.0)
Stainless Steel	12 (305)	<b>PWSS12</b>	1 (0.5)
	24 (610)	<b>PWSS24</b>	2 (1.0)
	36 (915)	<b>PWSS36</b>	2 (1.0)

#### Availability

**Stock:** Same day shipment

**Modified Stock**®: Five to seven working days

**Made-to-Order:** Three weeks

Options, complexity and quantity may affect availability and lead-times. Consult factory.

® Stock units with catalog options.