

**Quick Ship**

• Same day shipment on stock units with orders received by 11:00 a.m. CST.

## Flexible Heaters

### Flexible Shapes and Geometries

Flexible heaters from Watlow are just what the name implies: thin, bendable and shaped to fit your equipment. You can use your imagination to apply heat to the most complex shapes and geometries, without sacrificing efficiency or dependability. With Watlow's customization capabilities, you have the maximum amount of freedom when designing your equipment.

Excellent heat transfer results from the heater's thin design and its direct bonding to the application. Flexible heaters also provide fast heatup and cool down rates, uniform heat distribution and high watt densities.

#### Features and Benefits

- **Flat geometry** permits holes, notches and unusual shapes.
- **Four material types and two element styles** are available for wider flexibility in meeting your requirements. See next page for performance capabilities.
- **Lightweight construction and low thermal mass** permit use in applications that have limited space or weight requirements.
- **Heating elements** as close as 0.003 inches (0.08 mm) from the heated part respond to controls with faster heat up and cool down.
- **Uniformly spaced element paths**, placed within ¼ inch (6 mm) of the heater perimeter, distribute heat more evenly.

#### Applications

- Medical equipment such as blood analyzers, respiratory therapy units and hydrotherapy baths
- Satellite and communication equipment
- Freeze protection for military hardware, aircraft instrumentation, hydraulic equipment, etc.
- Battery heating
- Semiconductor equipment
- Foodservice equipment
- Any application requiring a flexible shape or design

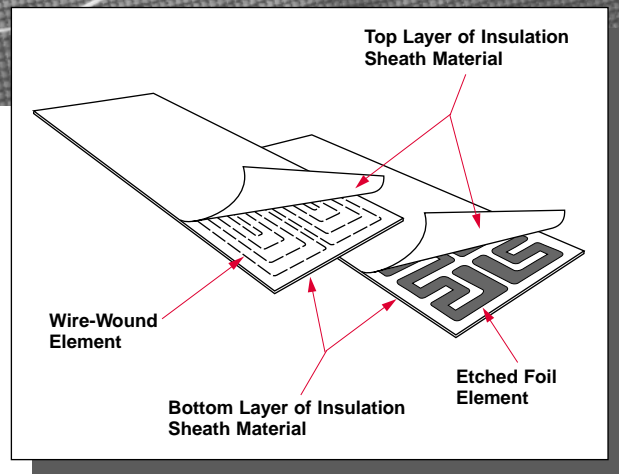
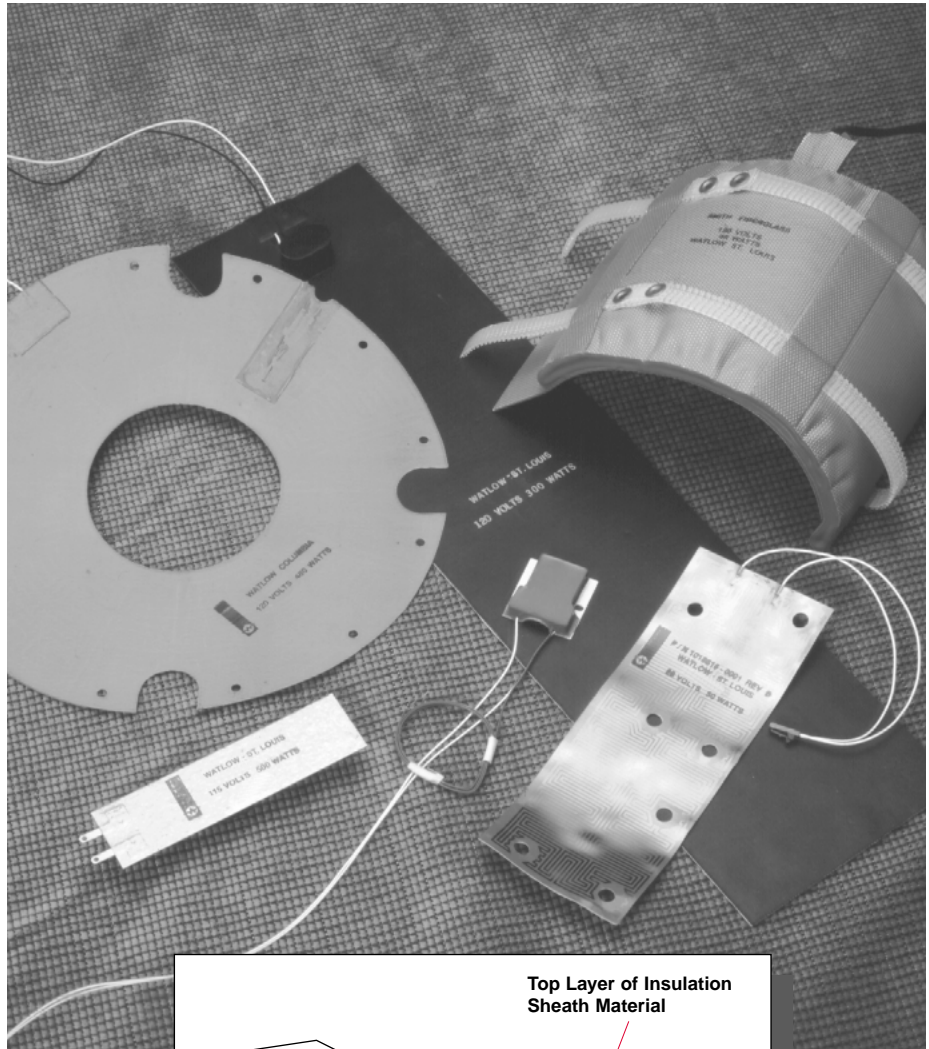

# Flexible Heaters

## Flexible Shapes and Geometries

### Applications and Technical Data

#### Four Material Types

##### Silicone Rubber:

This rugged, moisture- and chemical-resistant material is easily bonded or cemented to parts. Watlow silicone rubber heaters can handle temperatures up to 500°F (260°C). Many styles of these heaters are available with UR®, cUR® and VDE recognition. See [page 171](#) for details.

##### Kapton®:

A thin, lightweight transparent material from du Pont, Kapton® is designed for extremely precise heating requirements ranging from -319° to 392°F (-195° to 200°C). It is ideal for applications requiring low outgassing in a vacuum, or resistance to radiation, fungus and chemicals. Many custom heaters can be UR® and cUR® recognized.

##### Neoprene:

Neoprene resists weathering, abrasion and chemicals. It can be used economically in applications to 250°F (120°C), where high watt densities are not needed.

##### HT Foil:

This mica-insulated, high temperature foil is a semi-rigid heater. Operating temperatures up to 1100°F (595°C) can be achieved.



**See pages 169 to 182 and 189 to 194 for information on silicone rubber, Kapton®, neoprene, and HT foil heaters.**

Kapton® is a registered trademark of E.I. du Pont de Nemours & Company.

UR® and cUR® are registered trademarks of Underwriter's Laboratories, Inc.

### Two Element Types

Watlow offers both wire-wound and etched foil resistance elements. These element types are available in

most insulating materials, and Watlow can recommend the type best suited to your application.

#### Wire-Wound Elements

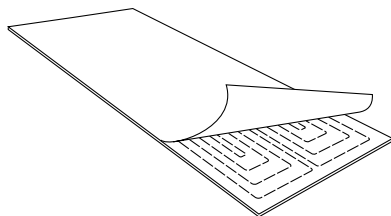

Available on silicone rubber and neoprene heaters, this element style is created by spiraling fine resistance wires around a fiberglass cord. The element is then laid out in a pattern designed specifically for your application. The benefits of wire-wound elements include:

- Excellent physical strength and flexibility; repeated flexing of the heater has no harmful effects on its performance
- Good economy for small production runs
- Conforms readily to curved surfaces, including small radius bends

Drum heaters and conduit bender heaters are typical examples of applications that use the wire-wound method. These heaters are flexed repeatedly during use, but due to their wiring, no internal damage will occur.

#### Etched Foil Elements

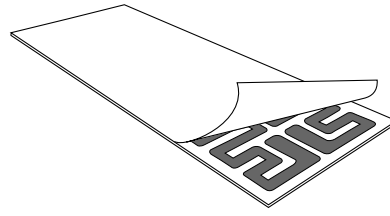

This element type, created by acid etching a circuit in nickel resistance alloy foil, is available in silicone rubber, Kapton® and HT foil heater types. The etched foil element is noted for its excellent circuit pattern repeatability and superior heat transfer, which results from greater area coverage of the element. Other benefits include:

- Delivers more heat and up to twice the watt density of a wire-wound element, providing longer heater life
  - Most economical for large production runs
  - Complex heat distribution patterns can be provided
- The etched foil element style is usually recommended for applications requiring high temperatures or watt densities, or multiple zoning.

## Flexible Heaters

### Flexible Shapes and Geometries Options

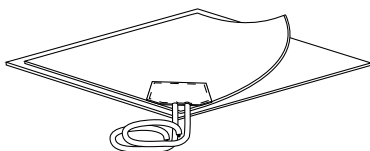

**Note:** PSAS maximum six months storage life before heater installation.

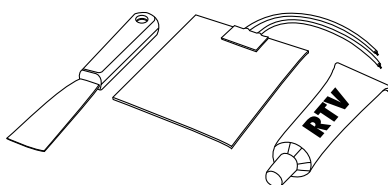

**Note:** Not recommended for Kapton® heaters.

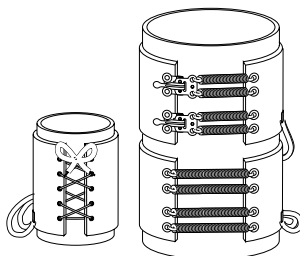
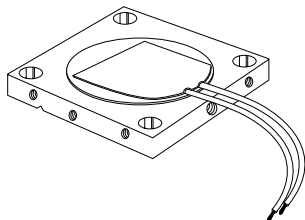
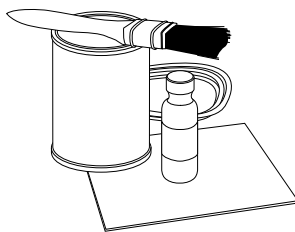

#### Mounting Methods

Watlow offers various attachment techniques, all designed for fast installation. These include: three types of adhesives; Watlow's special factory vulcanization process; and mechanical fasteners.

Complete installation instructions are available from Watlow. Ask for technical letter #2, silicone rubber heaters.

#### Pressure Sensitive Adhesive Surface (PSAS)

For speed, convenience and economy of installation, specify **PSAS**. Simply peel off the protective backing and roll the heater in place for an even bond to a clean, smooth surface.

**Note:** PSAS is not recommended for curved surfaces or for heaters rated above 10 W/in<sup>2</sup> (0.8 W/cm<sup>2</sup>). It should not be used for applications exceeding 400°F (205°C) on silicone rubber, 300°F (150°C) on Kapton® or 200°F (93°C) for neoprene.

#### Field Applied Adhesive (RTV)

For a stronger bond, or when long storage is probable, a **room temperature vulcanizing (RTV) silicone adhesive** is available from stock within two days. Watlow offers red RTV for temperatures up to 500°F (260°C). White RTV is available from adhesive suppliers for temperatures up to 400°F (205°C). Watlow's one-

part RTV is self-priming and can be ordered in either 3 oz (90 ml) or 12 oz (355 ml) tubes. For larger heaters requiring longer adhesive working time, two-part RTV kits can be purchased from adhesive suppliers. These kits require primer on the surface prior to application of the adhesive.

#### Silicone Contact Cement Kit

This two-part adhesive consists of a resin and catalyst which are easily mixed together and applied with a paintbrush. Recommended usage is for field cementing of silicone rubber heaters to customer parts. Available

from stock, the cement kit will handle temperatures to 350°F (175°C). The resin is available in pint or quart containers. To order, specify **silicone contact cement**, and container size.

#### Factory Bonding

This attachment technique provides a strong, void-free bond for excellent heat transfer and extended heater life. Watlow's expertise in bonding heaters to customer parts has proven extremely successful.

Bonding is recommended for applications that reach maximum temperatures of 500°F (260°C) on silicone rubber and 300°F (150°C) on Kapton®.

#### Mechanical Fasteners

When a wire-wound flexible heater must be detachable, any type of fastener normally used with fabrics can usually be built into the sheath material of Watlow flexible heaters. The most common types are latch fasteners, boot hooks and

grommets. Other styles include snap fasteners, springs, velcro style fastener strips and lacing cord. The grommets and boot hooks are commonly used with tension springs to compensate for slight variations in part size.

## Flexible Heaters

### Flexible Shapes and Geometries

#### Termination Styles

Watlow offers many types of leads and terminations. Leads can project from any position along the perimeter of the unit. **They will be centered on the short side width of rectangular heaters unless specified otherwise.**

#### Standard Leads—Type E Teflon®

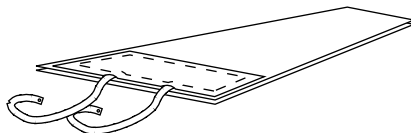

Leads shown exiting end of heater, centered on short side.

Watlow's standard leads are 12 inches (305 mm) long, white, Teflon® insulated, flexible, plated copper wire. They are rated for 392°F (200°C)/600 volts per MIL-W-16878, Type E. The lead connections on or at the heater are insulated with a cap of sheath material, vulcanized to the heater body. All custom flexible heaters except HT foil will be supplied with this lead type unless otherwise specified.

#### HPN Cord and Plug Set

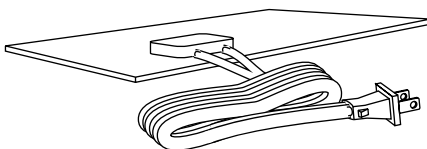

Molded leads are shown exiting edge of heater. Capped leads are also available.

For removable heaters, a six foot (1.8 m) HPN (neoprene insulated) cord and plug set provides convenience. It is rated for 194°F (90°C)/300V~(ac). HPN cord without a plug is also available in any length.

#### Silicone Insulated Leads

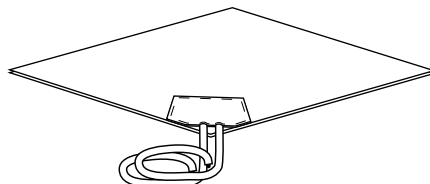

Leads shown exiting corner of heater.

For a better moisture seal, specify UL® silicone insulated lead wires. This lead type is rated for 302°F (150°C)/600V~(ac). Any lead length is available. Note: Silicone rubber heaters are not designed to be waterproof. Excess exposure to moisture may facilitate premature heater failure.

#### Special Teflon® Leads

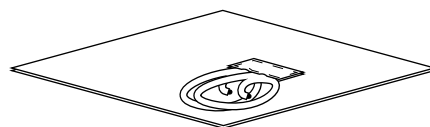

Leads shown exiting middle of heater.

Teflon® leads, UL® style 1180 and cUR® approved, are rated for 392°F (200°C)/300 volts. Any length is available. UL® Teflon® leads are standard on stock rectangles.

## Construction

#### Formed Heaters

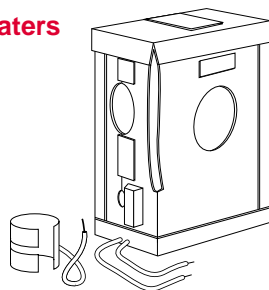

Many three-dimensional shapes, such as cylinders, cones and boxes, can be factory formed. Semi-rigid shapes can be self-gripping to the part. Special tooling may be required for some designs.

#### Holes, Cutouts and Notches

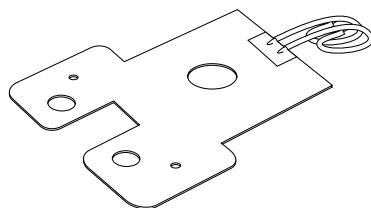

Watlow can provide flexible heaters with special holes, cutouts and notches in nearly any position required for your design. The resistance element can be brought to within 1/8 inch (3 mm) of all edges. Standard spacing is 1/4 inch (6 mm) from all edges.

Teflon® is a registered trademark of E.I. du Pont de Nemours & Company.

## Flexible Heaters

### Flexible Shapes and Geometries Temperature Sensors

Watlow offers several styles of sensors for use with flexible heaters. These sensors are available as preset or adjustable thermostats, thermocouples, thermistors, RTDs or thermal fuses. They can be integrally mounted (encapsulated in silicone rubber) to sense the temperature of either the part or the heater sheath. The thermostats can also be ordered separate from the heater, allowing direct control of your process temperature, if desired.

#### Pre-Set Thermostats

Several styles of non-adjustable, pre-set thermostats are available from Watlow. Thermostats separate from the heater are encapsulated in silicone rubber, and are available with standard 12 inch (305 mm) leads unless otherwise specified.

Thermocouples, thermistors, RTDs and thermal fuses are usually mounted to the heater under a vulcanized protective cap of silicone rubber sheath material. This drawing shows a typical mounting style for a thermocouple.

**Note:** Precise part temperature control with preset thermostats requires prototyping and field testing.

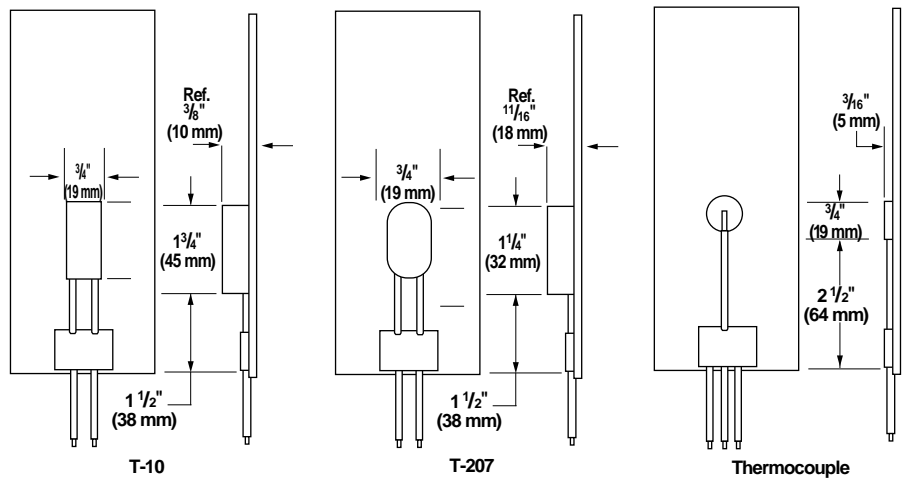

#### Pre-Set Thermostats (Non-Adjustable)

Thermostat Model	Maximum Watts	Volts AC	Temperature Settings Available °F (°C)	Agency Approvals		
				UR	cUR	VDE
<b>T-10</b>	600/960	120/240	125-300±10 (50-149±5)	yes	yes	yes
<b>T-207</b>	1500	120/240	40/55±8 (4/13±4.4)	yes	yes	yes
	1500	120/240	60/75±8 (16/24±4.4)	yes	yes	yes
	1500	120/240	95/110±8 (35/43±4.4)	yes	yes	yes
	1500	120/240	145/160±8 (63/71±4.4)	yes	yes	yes

**Notes:**

- When ordering a pre-set thermostat separate from the heater, simply add the prefix **S** to the model number. (Example: ST-10) See next page.
- Snap action preset temperatures on the T-207 are close/open settings.
- T-10 thermostats are manufactured for specific preset temperatures. Available in 25 F increments.
- Other temperature ranges and voltages are available on special order. Minimum quantities apply, so consult factory before ordering.

#### Adjustable Thermostats

The B-200 thermostat features a maximum rating of 1500 watts at 120/240V~(ac). The following temperature ranges are available:

- Model B-200-2: 100° to 500°F (40° to 260°C)

- Model B-200-3: 25° to 330°F (-5° to 165°C)

The B-200 thermostat can be integrally mounted to the heater with a bonded protective cap of silicone rubber sheath material.

# Flexible Heaters

## Flexible Shapes and Geometries

### Temperature Sensors

Continued

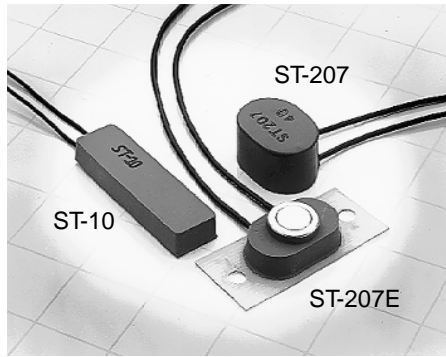

### Separate Heater Accessories Available From Stock

#### Pre-Set Thermostats Separate From Heater

These are offered to allow direct control of your process temperature, so you're not limited to controlling only the heater temperature when using stock heaters. Pre-set thermostats are encapsulated in silicone rubber with standard 12 inch leads.

The same temperature ranges, ratings and sizes are available on these thermostats. When ordering, add "S" prefix to the model number to indicate "separate" item. (Examples: ST-10 and ST-207)

Standard leads are 12 inch (305 mm) 18 ga. UL1180 black leads.

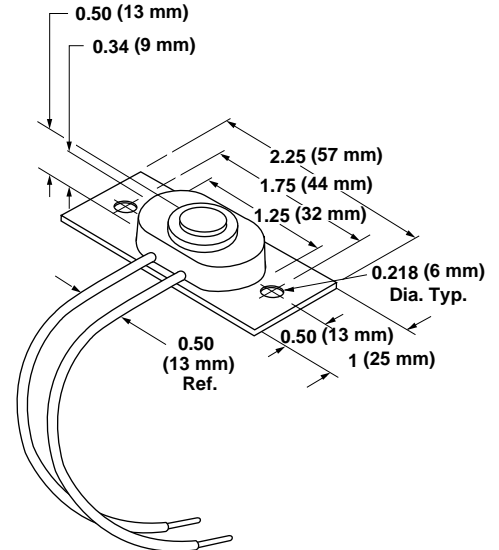

**Notes:** For direct control of air temperature as is required in enclosure heating applications, specify thermostat model number ST-207E. This is a modified ST-207 mounted on 1/2 inch thick G-10 circuit board with the thermostat's metal cap exposed to sense air temperature.

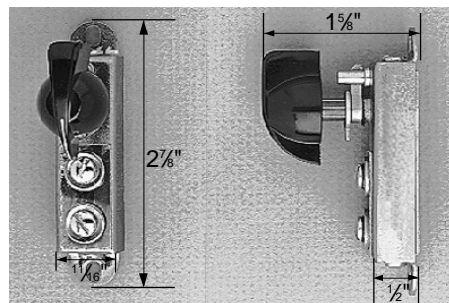

B-200

#### Adjustable Thermostats Separate From Heater

The Model B-200 adjustable thermostat can be ordered as a separate item. The same model numbers and temperature ranges

indicated under *Adjustable Thermostats* are available. When ordering, simply note that you want the **B-200 separate** from the heater.

**Quick Ship**

- Same day shipment on stock units with orders received by 11:00 a.m.

## Flexible Heaters

### Silicone Rubber

Rugged, yet thin, lightweight and flexible ... the use of Watlow silicone rubber heaters is limited only by your imagination. With these heaters, you can put the heat where it's needed and, in the process, improve heat transfer, speed warm-ups and decrease wattage requirements.

Fiberglass-reinforced silicone rubber gives your heater dimensional stability without sacrificing flexibility. Because very little material separates the element from the part, heat transfer is rapid and efficient.

#### Performance Capabilities

- Operating temperatures to 500°F (260°C)
- Watt densities to 80 W/in<sup>2</sup> (12.5 W/cm<sup>2</sup>) dependent upon application temperature
- 0.055 inch (1.4 mm) thick with a wire-wound element; only 0.018 inch (0.5 mm) with an etched foil element

#### Features and Benefits

- **Designed in the exact shape and size**, including 3-D geometries, to conform to your equipment.
- **More than 80 designs** available immediately from stock.
- **UR®, cUR® and VDE** recognitions are available on many designs.
- **Moisture and chemical-resistant** silicone rubber material provides longer heater life.
- **Easy to bond or attach** to your part through the use of vulcanizing, adhesives, or fasteners.

#### Applications

- Freeze protection and condensation prevention for many types of instrumentation and equipment
- Medical equipment such as blood analyzers, test tube heaters, etc.
- Computer peripherals such as laser printers
- Curing of plastic laminates
- Photo processing equipment

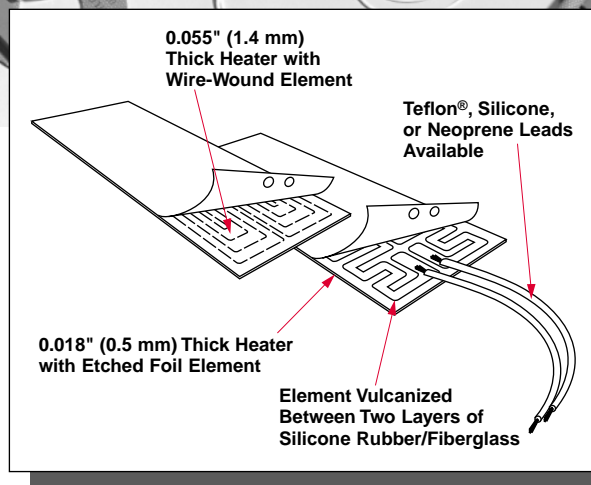

Teflon® is a registered trademark of the E.I. du Pont de Nemours & Company.

UR® and cUR® are registered trademarks of Underwriter's Laboratories, Inc.

# Flexible Heaters

## Silicone Rubber

### Applications and Technical Data

#### Determining Watt Density

The *Maximum Allowable Watt Density* graph illustrates the maximum recommended heater watt density at various metal part or ambient air temperatures. However, it does not indicate the watt density necessary to achieve a given part temperature. See the *Surface Temperature vs. Time* graph on the next page for assistance with those calculations. When using this graph, remember:

- Part temperature is measured at the point where the heater contacts the metal part.
- Thermostats and on-off controls are typically bimetal or capillary bulb.
- Non-cycling controls are typically solid state, time-proportioning or SCR temperature controllers.
- Watt density values should be derated by one third if insulation is used.
- UL® recognition temperature limits are not detailed.
- Consult Watlow before doing any of the following: selecting high watt density etched-foil elements, or operating heaters with back side insulation or non-metallic parts, which are poor thermal conductors.

**Example:** A wire-wound heater with non-cycling control at a part temperature of 250°F (120°C) can be rated at 24 W/in<sup>2</sup> (3.7 W/cm<sup>2</sup>) maximum. An etched foil heater under the same conditions can be rated at 45 W/in<sup>2</sup> (7 W/cm<sup>2</sup>) maximum.



#### Standard Silicone Rubber Specifications

##### Maximum width x maximum length:

- Wire wound: 36 x 120 inches (915 mm x 3050 mm)
- Etched foil: 20 x 30 inches (510 mm x 760 mm)

##### Thickness (standard):

- Wire wound: 0.055 inch (1.4 mm)
- Etched foil: 0.018 inch (0.5 mm)

##### Weight (standard):

- Wire wound: 8 oz./ft<sup>2</sup> (0.24 g/cm<sup>2</sup>)
- Etched foil: 3 oz./ft<sup>2</sup> (0.09 g/cm<sup>2</sup>)

**Maximum operating temperature:** 500°F (260°C)

**Maximum temperature for UL® recognition:** 428°F (220°C)

**Minimum ambient temperature:** -80°F (-62°C)

**Maximum voltage:** 600V~(ac)

**Maximum wattage:** See watt density graph

**Lead size:** Sized to load

**Lead length:** 12 + 1 ½ - ½ inches (305 mm + 40 mm - 15 mm)

##### Wattage tolerance:

- Wire: ±5 percent
- Foil: +5 percent -10 percent

##### Dimensional tolerances:

- 0 to 6 inches (0 to 150 mm): ±1/16 inch (1.6 mm)
- 6 to 18 inches (150 to 455 mm): ±1/8 inch (3.2 mm)
- 18 to 36 inches (455 mm to 915 mm): ±3/16 inch (4.8 mm)
- Over 36 inches (915 mm): ±1 percent

Government Supply Code Number

Cage code = 78056

UL® is registered trademark of Underwriter's Laboratories, Inc.

## Flexible Heaters

### Silicone Rubber

#### Applications and Technical Data

Continued

#### Surface Temperature vs. Time

This graph illustrates the surface temperature a silicone rubber heater will reach when the heater is uninsulated and is suspended

vertically in 70°F (20°C) still air. This data is based on 0.055 inch (1.4 mm) thick standard construction and is offered as a reference tool.

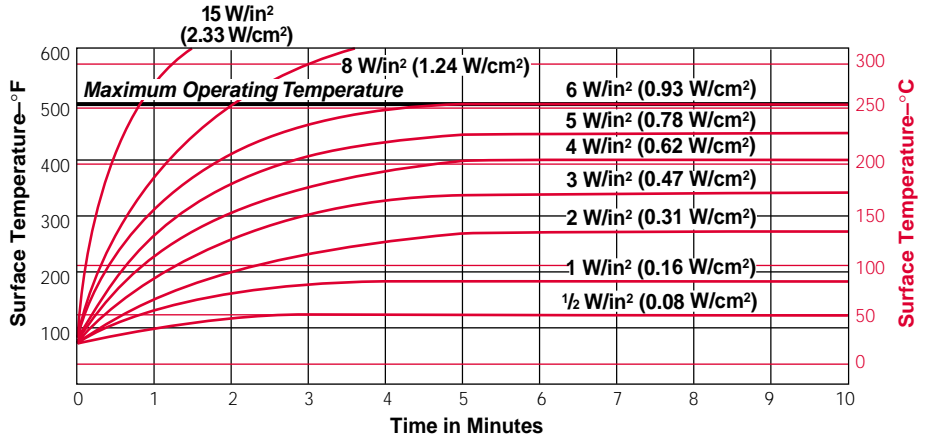

#### UR®, cUR® and VDE Recognition for Silicone Rubber Heaters

Watlow frequently works with customers requiring agency approvals such as UR®, cUR® and VDE. Many stock silicone rubber heaters are available with one or more of these certifications.

**Watlow's technical letter #3**, flexible heaters, provides in-depth information on agency approvals.

#### UL® Component Recognition (UR)

of factory-bonded heaters is available up to 392°F (200°C), and for customer installed heaters up to 428°F (220°C) (UL File No. E52951).

For Canadian recognition Watlow offers **cUR Recognized®** silicone rubber heaters under UL File #E52951. Several constructions are available with ratings to 600V~(ac) and 428°F (220°C) maximum surface temperature. Consult the factory for further information.

**VDE Approval** is available on several constructions of both wire-wound (File No. 62533) and etched foil (File No. 62535) silicone rubber heaters. The maximum ratings are 440V~(ac) and 428°F (220°C) surface temperature. Under VDE guidelines, minimum installed bend radius is 1/8 inch (3 mm) for etched foil and 1/4 inch (6 mm) for wire wound.

VDE also states that the user is responsible for the safe application, installation and wiring of the heaters. Maximum working temperature must be maintained by an appropriate temperature control.

### Options

Watlow offers a variety of options such as attachment techniques, thermostats, special leads, holes and cutouts and three-dimensional shapes. These are all described in the introduction to flexible heaters section. In addition, the following option is available only on silicone rubber heaters.

#### Thermal Insulation

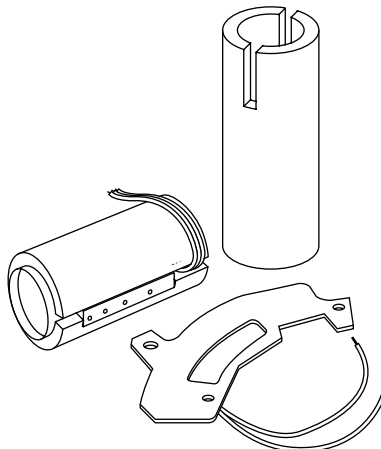

To increase the heating efficiency of your application, silicone rubber heaters can be thermally insulated with silicone sponge rubber, bonded to one side in the following thicknesses: 1/16, 1/8, 1/4, 3/8 or 1/2 inch (1.6, 3, 6, 10 or 13 mm). Heaters with thermal insulation are still quite flexible.

An aluminized surface can be added to the back of the heater to reduce radiated heat losses. This aluminized surface, called "Low Loss Treatment," adds very little to the unit thickness and maintains a very clean appearance.



See pages 165 to 168 for more information on options.

Flexible Heaters

# Flexible Heaters

F.O.B.: Columbia, Missouri

## Silicone Rubber Wire-Wound Element

Width in (mm)	Length in (mm)	Watts	Availability	120V~(ac) Code No.	240V~(ac) Code No.
1 (25)	2 (50)	10	Stock	010020C1	
	3 (75)	15	Stock	010030C1	
	4 (100)	20	Stock	010040C1	
	5 (125)	25	Stock	010050C1	
	5 (125)	25	Stock		010050C2
	10 (255)	50	Stock	010100C1	
	10 (255)	50	Stock		010100C2
	15 (380)	75	Stock	010150C1	
	15 (380)	75	Stock		010150C2
	20 (510)	100	Stock	010200C1	
	20 (510)	100	Stock		010200C2
	25 (635)	125	Stock	010250C1	
	30 (760)	150	Stock	010300C1	
	35 (890)	175	Stock	010350C1	
	40 (1015)	200	Stock	010400C1	
	80 (2030)	400	Stock	010800C1	
120 (3050)	600	Stock	010F10C1 <sup>①</sup>		
2 (50)	2 (50)	20	Stock	020020C1	
	5 (125)	50	Stock	020050C1	
	5 (125)	50	Stock		020050C2
	10 (255)	100	Stock	020100C1	
	10 (255)	100	Stock		020100C2
	15 (380)	150	Stock	020150C1	
	15 (380)	150	Stock		020150C2
	20 (510)	200	Stock	020200C1	
	20 (510)	200	Stock		020200C2
	25 (635)	250	Stock	020250C1	
	30 (760)	300	Stock	020300C1	
	35 (890)	350	Stock	020350C1	
	40 (1015)	400	Stock	020400C1	

CONTINUED 

① 010F10C1 - F = feet (i.e. 10 feet = 120 inches)

Approx. net weight: 8 ounces/ft<sup>2</sup> (0.24 g/cm<sup>2</sup>). Standard thickness: 0.055 inch. Standard lead length: 12 inches UL 1180 Teflon®.

Silicone rubber wire-wound elements rated at 5 W/in<sup>2</sup>.

UL® Component Recognition (UR®).

### How to Order

To order stock silicone rubber heaters, specify the Watlow code number and the quantity. To order a heater with options, specify the code number, quantity and options desired (**see page 165**). Consult Watlow before combining options.

### Made-to-Order: Consult factory.

For **made-to-order** units, Watlow will need the following application information from you:

- Size (dimensions)
- Voltage
- Wattage/watt density
- Operating temperature
- Options (leads, thermostats, attachment techniques, etc.)
- Will heater be subject to flexing?
- Element type, if you have a preference
- Agency approvals
- Quantity

### Availability

**Stock:** Same day shipment of orders received by 11:00 a.m. CST.

**Stock with Options:** Shipment in five working days or less. Not all options are available with stock heaters.

## Flexible Heaters

### Silicone Rubber

#### Wire-Wound Element

Width in (mm)	Length in (mm)	Watts	Availability	120V~(ac) Code No.	240V~(ac) Code No.	
3 (75)	3 (75)	45	Stock	<b>030030C1</b>		
	5 (125)	75	Stock	<b>030050C1</b>		
	5 (125)	75	Stock		<b>030050C2</b>	
	10 (255)	150	Stock	<b>030100C1</b>		
	10 (255)	150	Stock		<b>030100C2</b>	
	15 (380)	225	Stock	<b>030150C1</b>		
	15 (380)	225	Stock		<b>030150C2</b>	
	20 (510)	300	Stock	<b>030200C1</b>		
	20 (510)	300	Stock		<b>030200C2</b>	
	25 (635)	375	Stock	<b>030250C1</b>		
	30 (760)	450	Stock	<b>030300C1</b>		
	35 (890)	525	Stock	<b>030350C1</b>		
	40 (1015)	600	Stock	<b>030400C1</b>		
	4 (100)	4 (100)	80	Stock	<b>040040C1</b>	
5 (125)		100	Stock	<b>040050C1</b>		
5 (125)		100	Stock		<b>040050C2</b>	
10 (255)		200	Stock	<b>040100C1</b>		
10 (255)		200	Stock		<b>040100C2</b>	
15 (380)		300	Stock	<b>040150C1</b>		
15 (380)		300	Stock		<b>040150C2</b>	
20 (510)		400	Stock	<b>040200C1</b>		
20 (510)		400	Stock		<b>040200C2</b>	
25 (635)		500	Stock	<b>040250C1</b>		
30 (760)		600	Stock	<b>040300C1</b>		
35 (890)		700	Stock	<b>040350C1</b>		
40 (1015)		800	Stock	<b>040400C1</b>		
5 (125)		5 (125)	125	Stock	<b>050050C1</b>	
	5 (125)	125	Stock		<b>050050C2</b>	
	10 (255)	250	Stock	<b>050100C1</b>		
	10 (255)	250	Stock		<b>050100C2</b>	
	15 (380)	375	Stock	<b>050150C1</b>		
	15 (380)	375	Stock		<b>050150C2</b>	
	20 (510)	500	Stock	<b>050200C1</b>		
	20 (510)	500	Stock		<b>050200C2</b>	
	25 (635)	625	Stock	<b>050250C1</b>		
	30 (760)	750	Stock	<b>050300C1</b>		
	35 (890)	875	Stock	<b>050350C1</b>		
	40 (1015)	1000	Stock	<b>050400C1</b>		
	6 (150)	5 (125)	150	Stock	<b>060050C1</b>	
		5 (125)	150	Stock		<b>060050C2</b>
10 (255)		300	Stock	<b>060100C1</b>		
10 (255)		300	Stock		<b>060100C2</b>	
15 (380)		450	Stock	<b>060150C1</b>		
15 (380)		450	Stock		<b>060150C2</b>	
20 (510)		600	Stock	<b>060200C1</b>		
20 (510)		600	Stock		<b>060200C2</b>	
25 (635)		750	Stock	<b>060250C1</b>		
30 (760)		900	Stock	<b>060300C1</b>		
35 (889)		1050	Stock	<b>060350C1</b>		
40 (1016)		1200	Stock	<b>060400C1</b>		

Flexible Heaters

Approx. net weight: 8 ounces/ft<sup>2</sup> (0.24 g/cm<sup>2</sup>). Standard thickness: 0.055 inch. Standard lead length: 12 inches UL 1180 Teflon®. Silicone rubber wire-wound elements rated at 5 W/in<sup>2</sup>. UL® Component Recognition (UR®).

# Flexible Heaters

## Silicone Rubber

### Wire-Wound Stock Heater Coding Configured Options

#### How to order

To order, complete the code number with the information below:

Wire wound (p. 172-173)

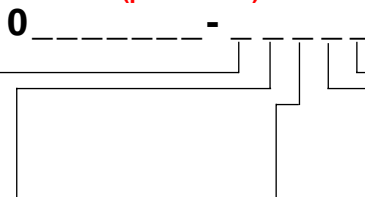

Modification Options	
0	= None
A	= PSAS Bottom
B	= PSAS Top
E	= With Plate. Heater on Side Opposite Flange
F	= With Plate. Heater on Flange Side
G	= Flaps + Grommets
H	= Flaps + Boot Hooks
J	= Flaps + Latch Fasteners
K	= PSAS and Low Loss
L	= Low Loss
M	= Low Loss + Flaps + Grommets
N	= Low Loss + Flaps + Boot Hooks
P	= Low Loss + Flaps + Latch Fasteners
R	= 1/16 inch Sponge
S	= 1/8 inch Sponge
T	= 1/4 inch Sponge
U	= 3/8 inch Sponge
V	= 1/2 inch Sponge
W	= PSAS + 1/16 inch Sponge
Y	= PSAS + 1/8 inch Sponge
1	= PSAS + 1/4 inch Sponge
2	= PSAS + 3/8 inch Sponge
3	= PSAS + 1/2 inch Sponge
4	= Tip Plugs
6	= Tip Plugs/PSAS

• Heaters with flaps must be minimum 10 inches long.

Sensors		
Type	LOC	WIR
0	= None	
L	= T10 STD	STD
M	= T10 STD	ALT
N	= T10 ALT	STD
P	= T10 ALT	ALT
R	= T207 STD	STD
S	= T207 STD	ALT
T	= T207 ALT	STD
U	= T207 ALT	ALT
V	= T207E on heater	STD
W	= T207E Remote	STD
Y	= B200 STD	STD
1	= B200 STD	ALT
2	= B200 ALT	STD
3	= B200 ALT	ALT
4	= JSTD STD	STD
6	= JALT STD	STD
7	= KSTD STD	STD

• For thermostats, standard location is as shown in catalog; standard wiring is integral or series with the heater; alternate location is rotated parallel with heater width; alternate wiring is separate leads for pilot control.

• For thermocouples, J standard is Teflon® insulation; J alternate is fiberglass insulation; K standard is fiberglass insulation.

T10 Set °F*	
0	= None
A	= 125
B	= 150
E	= 175
F	= 200
G	= 225
H	= 250
J	= 275
K	= 300

T207 Set °F*	
0	= None
1	= 40/55
2	= 60/75
3	= 95/110
4	= 145/1600

B200 Set °F*	
0	= None
2	= 500
3	= 330

T/C Length	
0	= None
A	= 8 in
B	= 12 in
E	= 18 in
F	= 24 in
G	= 30 in
H	= 36 in
J	= 40 in
K	= 4 ft
L	= 5 ft
M	= 6 ft
N	= 7 ft
P	= 8 ft
R	= 9 ft
S	= 10 ft
T	= 12 ft
U	= 15 ft
V	= 18 ft
W	= 20 ft
Y	= 22 ft
1	= 25 ft
2	= 30 ft

\* For all thermostats, the heater must be two inches minimum width and five inches minimum length.

Lead Insulation	
0	= None
1	= 1180 Teflon®
2	= 1180 cJR®
3	= 3133 22 GA
4	= 3134 18 GA
6	= 1199 cJR®
7	= HPN
8	= 6 foot HPN Set
9	= Type E Teflon®
A	= 1180VDE*
B	= 1199VDE*

\* 1180VDE denotes a cJR® heater plus a VDE stamp.

Lead Length	
A	= 8 in
B	= 12 in
E	= 18 in
F	= 24 in
G	= 30 in
H	= 36 in
J	= 40 in
K	= 4 ft
L	= 5 ft
M	= 6 ft
N	= 7 ft
P	= 8 ft
R	= 9 ft
S	= 10 ft
T	= 12 ft
U	= 15 ft
V	= 18 ft
W	= 20 ft
Y	= 22 ft
1	= 25 ft
2	= 30 ft

#### Availability:

Modified Stock: Shipment within five working days

# Flexible Heaters

## Silicone Rubber

### Etched Foil Element

Width in (mm)	Length in (mm)	Watts	W/in <sup>2</sup> (W/cm <sup>2</sup> )	Availability	120V~(ac) Code No.	120/240V~(ac) Code No.
1 (25)	5 (125)	25	5 (0.8)	Stock	<b>F010050C3</b>	
	5 (125)	50	10 (1.6)	Stock	<b>F010050C7</b>	
	5 (125)	12.5/50	2.5/10 (0.4/1.6)	Stock		<b>F010050C8</b>
	10 (255)	100	10 (1.6)	Stock	<b>F010100C7</b>	
	10 (255)	25/100	2.5/10 (0.4/1.6)	Stock		<b>F010100C8</b>
	15 (380)	150	10 (1.6)	Stock	<b>F010150C7</b>	
	15 (380)	37.5/150	2.5/10 (0.4/1.6)	Stock		<b>F010150C8</b>
	20 (510)	200	10 (1.6)	Stock	<b>F010200C7</b>	
2 (50)	5 (125)	100	10 (1.6)	Stock	<b>F020050C7</b>	
	5 (125)	25/100	2.5 /10 (0.4/1.6)	Stock		<b>F020050C8</b>
	10 (255)	200	10 (1.6)	Stock	<b>F020100C7</b>	
	10 (255)	50/200	2.5 /10 (0.4/1.6)	Stock		<b>F020100C8</b>
	15 (380)	300	10 (1.6)	Stock	<b>F020150C7</b>	
	15 (380)	75/300	2.5/10 (0.4/1.6)	Stock		<b>F020150C8</b>
	20 (510)	400	10 (1.6)	Stock	<b>F020200C7</b>	
	20 (510)	100/400	2.5/10 (0.4/1.6)	Stock		<b>F020200C8</b>
3 (75)	5 (125)	75	5 (0.8)	Stock	<b>F030050C3</b>	
	5 (125)	150	10 (1.6)	Stock	<b>F030050C7</b>	
	5 (125)	37.5/150	2.5 /10 (0.4/1.6)	Stock		<b>F030050C8</b>
	10 (255)	300	10 (1.6)	Stock	<b>F030100C7</b>	
	10 (255)	75/300	2.5 /10 (0.4/1.6)	Stock		<b>F030100C8</b>
	15 (380)	450	10 (1.6)	Stock	<b>F030150C7</b>	
	15 (380)	112/450	2.5 /10 (0.4/1.6)	Stock		<b>F030150C8</b>
	20 (510)	600	10 (1.6)	Stock	<b>F030200C7</b>	
4 (100)	5 (125)	200	10 (1.6)	Stock	<b>F040050C7</b>	
	5 (125)	50/200	2.5 /10 (0.4/1.6)	Stock		<b>F040050C8</b>
	10 (255)	400	10 (1.6)	Stock	<b>F040100C7</b>	
	10 (255)	100/400	2.5 /10 (0.4/1.6)	Stock		<b>F040100C8</b>
	15 (380)	600	10 (1.6)	Stock	<b>F040150C7</b>	
	15 (380)	150/600	2.5/10 (0.4/1.6)	Stock		<b>F040150C8</b>
	20 (510)	800	10 (1.6)	Stock	<b>F040200C7</b>	
	20 (510)	200/800	2.5/10 (0.4/1.6)	Stock		<b>F040200C8</b>
5 (125)	5 (125)	125	5 (0.8)	Stock	<b>F050050C3</b>	
	5 (125)	250	10 (1.6)	Stock	<b>F050050C7</b>	
	5 (125)	62.5/250	2.5/10 (0.4/1.6)	Stock		<b>F050050C8</b>
	10 (255)	500	10 (1.6)	Stock	<b>F050100C7</b>	
	10 (255)	125/500	2.5/10 (0.4/1.6)	Stock		<b>F050100C8</b>
	15 (380)	750	10 (1.6)	Stock	<b>F050150C7</b>	
	15 (380)	187/750	2.5/10 (0.4/1.6)	Stock		<b>F050150C8</b>
	20 (510)	1000	10 (1.6)	Stock	<b>F050200C7</b>	
6 (150)	5 (125)	300	10 (1.6)	Stock	<b>F060050C7</b>	
	5 (125)	75/300	2.5/10 (0.4/1.6)	Stock		<b>F060050C8</b>
	10 (255)	600	10 (1.6)	Stock	<b>F060100C7</b>	
	10 (255)	150/600	2.5 /10 (0.4/1.6)	Stock		<b>F060100C8</b>
	15 (380)	900	10 (1.6)	Stock	<b>F060150C7</b>	
	15 (380)	225/900	2.5/10 (0.4/1.6)	Stock		<b>F060150C8</b>
	20 (510)	1200	10 (1.6)	Stock	<b>F060200C7</b>	
	20 (510)	300/1200	2.5/10 (0.4/1.6)	Stock		<b>F060200C8</b>

Flexible Heaters

Approx. net weight: 3 ounces/ft<sup>2</sup> (0.09 g/cm<sup>2</sup>). Standard lead length: 12 inches UL 1180 Teflon®.  
 Silicone rubber etched foil elements are 0.018 inch thick.  
 UL® Component Recognition (UR®).

# Flexible Heaters

## Silicone Rubber

### Etched Foil Stock Heater

### Coding Configured Options

### How to order

To order, complete the code number with the information below:

Etched Foil (p. 175)  
**F0** \_\_\_\_\_ - \_\_\_\_\_

Options
0 = None
A = PSAS Bottom
B = PSAS Top
K = PSAS and Low Loss
L = Low Loss
R = 1/16 inch Sponge
S = 1/8 inch Sponge
T = 1/4 inch Sponge
U = 3/8 inch Sponge
V = 1/2 inch Sponge
W = PSAS + 1/16 inch Sponge
Y = PSAS + 1/8 inch Sponge
1 = PSAS + 1/4 inch Sponge
2 = PSAS + 3/8 inch Sponge
3 = PSAS + 1/2 inch Sponge
4 = Tip Plugs
6 = Tip Plugs/PSAS

• Etched foil heaters not recommended for enclosure heaters.

Sensors	LOC	WIR
0 = None		
L = T10	STD	STD
M = T10	STD	ALT
N = T10	ALT	STD
P = T10	ALT	ALT
R = T207	STD	STD
S = T207	STD	ALT
T = T207	ALT	STD
U = T207	ALT	ALT
4 = JSTD	STD	STD
6 = JALT	STD	STD
7 = KSTD	STD	STD

• For thermostats, standard location is as shown in catalog; standard wiring is integral or series with the heater; alternate location is rotated parallel with heater width; alternate wiring is separate leads for pilot control.

• For thermocouples, J standard is Teflon® insulation; J alternate is fiberglass insulation; K standard is fiberglass insulation.

T10 Set °F*
0 = None
A = 125
B = 150
E = 175
F = 200
G = 225
H = 250
J = 275
K = 300

T207 Set °F*
0 = None
1 = 40/55
2 = 60/75
3 = 95/110
4 = 145/160

T/C Length
0 = None
A = 8 in
B = 12 in
E = 18 in
F = 24 in
G = 30 in
H = 36 in
J = 40 in
K = 4 ft
L = 5 ft
M = 6 ft
N = 7 ft
P = 8 ft
R = 9 ft
S = 10 ft
T = 12 ft
U = 15 ft
V = 18 ft
W = 20 ft
Y = 22 ft
1 = 25 ft
2 = 30 ft

\* For preset thermostats, the heater must be two inches minimum width and five inches minimum length.

Lead Insulation
0 = None
1 = 1180 Teflon®
2 = 1180 cUR®
3 = 3133 22 GA
4 = 3134 18 GA
6 = 1199 cUR®
7 = HPN
8 = 6 Foot HPN Set
9 = Type E Teflon®
A = 1180VDE*
B = 1199VDE*

\*1180VDE denotes a cUR® heater plus a VDE stamp.

Lead Length
A = 8 in
B = 12 in
E = 18 in
F = 24 in
G = 30 in
H = 36 in
J = 40 in
K = 4 ft
L = 5 ft
M = 6 ft
N = 7 ft
P = 8 ft
R = 9 ft
S = 10 ft
U = 15 ft
V = 18 ft
W = 20 ft
Y = 22 ft
1 = 25 ft
2 = 30 ft

### Availability:

Modified Stock: Shipment within five working days

# Flexible Heaters

## Silicone Rubber Stock Product Offering Enclosure Heaters— Wire-Wound Only

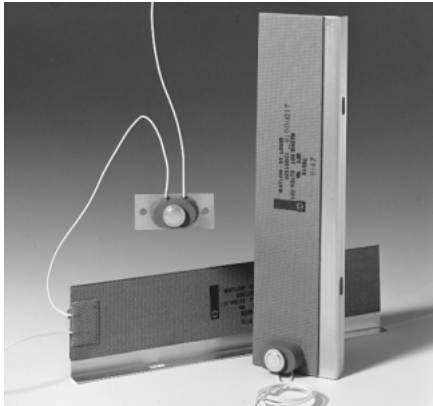

Designed for freeze and condensation protection, Watlow's enclosure heaters are rugged, reliable and safe to operate. These rectangular-shaped, wire-wound silicone rubber heaters can be ordered by themselves with adhesive or vulcanized to an aluminum mounting plate. A thermostat can be attached to the heater or mounted separately. Pictured are units with thermostat on heater in foreground and heater with remote thermostat in background.

### Performance Capabilities

- Watt density rating of 5 W/in<sup>2</sup> (0.8 W/cm<sup>2</sup>)
- Temperatures to 150°F (66°C)

### Features and Benefits

- **Easy to install** with options of pressure sensitive adhesive, mounting to aluminum plate, or customer cementing.
- **Quick delivery** on more than 72 variations.
- **Safe and reliable operation** due to no exposed electrical connections.
- **Custom leads** available in any length needed.
- **Horizontal and vertical mounting** options to meet your needs.

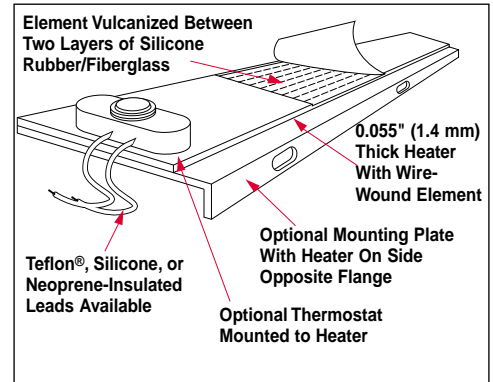

### Applications

Freeze or condensation prevention in housings containing electronic equipment. Examples include:

- Traffic signal boxes
- Automatic teller machines
- Temperature control panels
- Gas or liquid control valve housings

## Applications and Technical Data

### Determining Minimum Wattage Requirements For Enclosures

This chart is an excellent guide for determining total wattage requirements for both insulated

and uninsulated enclosures, assuming the box is relatively airtight. For windy conditions, add an additional 50 percent to the wattage requirement listed.

		Total Enclosure Surface Area—Square Feet (Square Meters)													
		2 (0.2)	3 (0.3)	4 (0.4)	5 (0.5)	6 (0.6)	7.5 (0.7)	9 (0.8)	10 (0.9)	15 (1.4)	20 (1.9)	25 (2.3)	30 (2.8)	40 (3.7)	50 (4.7)
Temperature Rise from Ambient °F (°C)	20 (11)	30 10	40 10	55 15	70 20	80 20	100 25	120 30	135 35	205 50	270 65	335 80	405 100	540 130	670 160
	40 (22)	55 15	80 20	110 30	135 35	160 40	200 50	245 60	270 65	405 100	540 130	670 160	805 195	1075 260	1340 320
		90 20	120 30	160 55	205 50	245 60	300 75	365 90	405 100	605 145	805 195	1005 240	1210 290	1610 385	2010 480
	80 (44)	110 30	160 40	215 55	270 65	325 80	400 100	485 115	540 130	805 195	1075 260	1340 320	1610 385	2145 515	2680 640
		135 35	200 50	270 65	335 80	405 100	500 125	605 145	670 160	1005 240	1340 320	1675 400	2010 480	2680 640	3350 800
	120 (67)	165 40	240 60	320 80	405 100	485 115	600 150	725 175	805 195	1210 290	1610 385	2010 480	2415 580	3220 770	4020 960
		190 45	280 70	375 90	470 115	565 135	700 175	845 205	940 225	1410 340	1880 450	2345 560	2815 675	3755 900	4690 1120

□ Uninsulated boxes    □ Insulated boxes

## Flexible Heaters

### Silicone Rubber Stock Product Offering Enclosure Heaters Options

#### Aluminum Mounting Plate

Both vertical and horizontal mounting can be accomplished with enclosure heaters. The mounting plates are 0.040 inch (1 mm) thick, specified as #3003 H14 aluminum. The preferred orientation is vertical, with a thermostat attached at the lower end (as shown in the drawing).

For horizontal mounting, a remote thermostat is recommended. An enclosure heater can be ordered by itself, with PSAS or vulcanized to an aluminum mounting plate. See *Thermostats* below for more information.

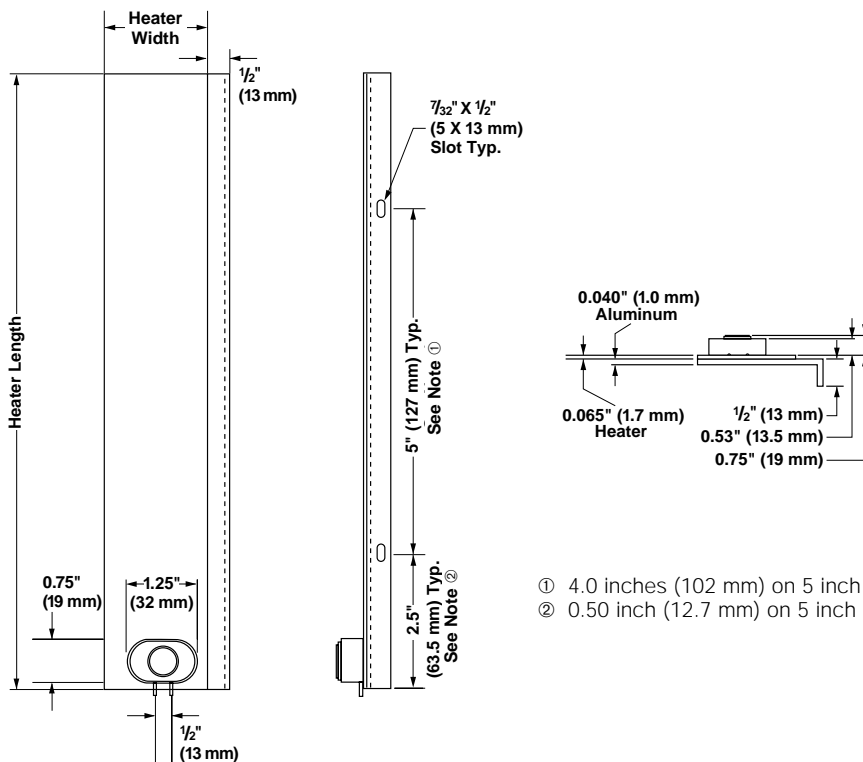

- ① 4.0 inches (102 mm) on 5 inch unit.  
② 0.50 inch (12.7 mm) on 5 inch unit.

### Thermostats

#### Mounted on Heater

Built-in snap action thermostats from Watlow are designed to sense air temperature. See the ordering chart on the following page for available settings.

#### Remote From Heater

For an air sensing thermostat separate from the heater, the ST-207E is ideal. This is a modified ST-207 mounted on a 1/32 inch (0.8 mm) thick G-10 circuit board with the thermostat's metal cap exposed to sense air temperature. The thermostat is placed at the

midpoint of the lead length. The sensor can be preset at the temperatures listed for integral sensors. For more information, turn to **pages 167-168**.

#### Notes:

- On both integral and remote sensors, the thermostat's exposed metal cap is vulnerable to impact. This could defeat the thermostat's switching action and cause heater malfunction.
- T-10 thermostats are not recommended for enclosure heating applications.

## Flexible Heaters

### Silicone Rubber Stock Product Offering Drum Heaters

#### Performance Capabilities

- Available with fixed or adjustable thermostats for temperatures up to 330°F (165°C)
- Watt density of 6 W/in<sup>2</sup> (1 W/cm<sup>2</sup>)

#### Features and Benefits

- **Protects fluids** stored in drums from freezing temperatures.
- **Quick delivery** on 28 styles from stock.
- **Six-foot cord and plug set** included for convenient use.
- **Quick installation** with easy operating latch fasteners.
- **Custom heaters** available for non-standard sizes.

#### Applications

- Freeze protection
- Viscosity control

#### Application Hints

- Allow a three-inch (76 mm) gap between heater ends when clamped around a drum.
- Heaters with thermostat settings of 40°F and 60°F (4°C and 16°C) will have open circuit readings if room temperature exceeds the thermostat settings.
- Heaters cannot be bench tested since the thermostat is located over a no-heat section of the heater. Accurate testing of the heater requires it to be placed over the drum which is to be heated.
- When a single heater is used, place the heater at the bottom of the drum to minimize stratification.



#### Standard Features

Watlow flexible drum heaters are designed for use on 5-, 30-, and 55-gallon **metal** drums. They come with the following standard features:

- Six-foot (1.8 m) cord and plug set
- Latch fasteners and springs

- Two styles of thermostats:  
T-207 snap action, available on all sizes  
B-200-3 adjustable, available only on four-inch (100 mm) wide units, and mounted in a silicone rubber boot to protect it from contamination

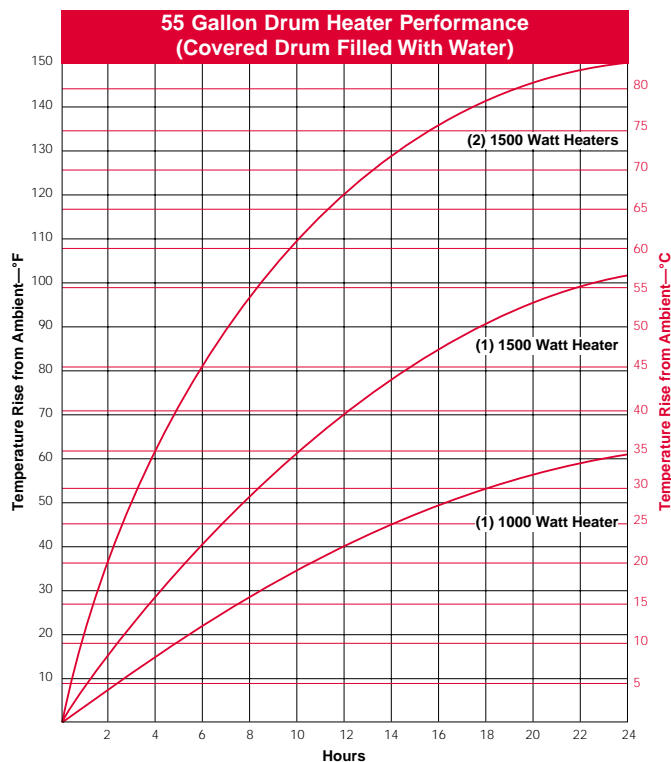

#### Determining Temperature Rise From Ambient

The total wattage (number of heaters and the material being heated) must be considered when estimating the

actual temperature the contents of the drum will reach. The graph above shows the temperature rise from ambient conditions, not drum content temperature.



**For more information on thermostats, turn to pages 167 to 168.**

# Flexible Heaters

F.O.B.: Columbia, Missouri

## Silicone Rubber Stock Product Offering Drum Heaters

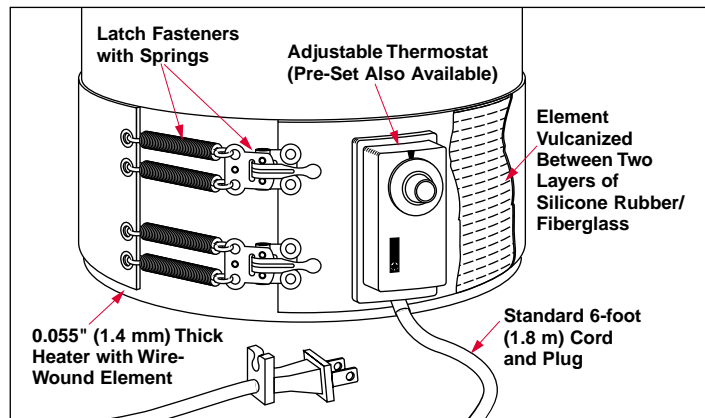

Drum Size	Volts	Watts	Width inches (mm)	Thermostat	Availability	Code No.
5 gal. (20 L) 11 1/2 in. (290 mm) nom. diameter	120	650	4 (100)	(no thermostat)	Stock	<b>04031500A</b>
				150°F (66°C)	Modified Stock	<b>04031500BT</b>
				100°F (38°C)	Modified Stock	<b>04031500CT</b>
				40°F (4°C)	Modified Stock	<b>04031500DT</b>
				60°F (16°C)	Modified Stock	<b>04031500HT</b>
				Adj. 25°-330°F (-5°-165°C)	Stock	<b>04031510</b>
30 gal. (115 L) 18 1/2 in. (470 mm) nom. diameter	120	750	2 1/16 (70)	(no thermostat)	Stock	<b>02655080A</b>
				150°F (66°C)	Modified Stock	<b>02655080BT</b>
				100°F (38°C)	Modified Stock	<b>02655080CT</b>
				40°F (4°C)	Modified Stock	<b>02655080DT</b>
				60°F (16°C)	Modified Stock	<b>02655080ET</b>
55 gal. (210 L) 22 1/2 in. (570 mm) nom. diameter	120	1000	2 1/16 (70)	(no thermostat)	Stock	<b>02667700A</b>
				150°F (66°C)	Modified Stock	<b>02667700BT</b>
				100°F (38°C)	Modified Stock	<b>02667700CT</b>
				40°F (4°C)	Modified Stock	<b>02667700DT</b>
				60°F (16°C)	Modified Stock	<b>02667700ET</b>
55 gal. (210 L) 22 1/2 in. (570 mm) nom. diameter	120	1500	4 (100)	(no thermostat)	Stock	<b>04067700A</b>
				150°F (66°C)	Modified Stock	<b>04067700BT</b>
				100°F (38°C)	Modified Stock	<b>04067700CT</b>
				40°F (4°C)	Modified Stock	<b>04067700DT</b>
				60°F (16°C)	Modified Stock	<b>04067700GT</b>
				Adj. 25°-330°F (-5°-165°C)	Stock	<b>04067710</b>
55 gal. (210 L) 22 1/2 in. (570 mm) nom. diameter	240	1500	4 (100)	(no thermostat)	Stock	<b>04067701A</b>
				150°F (66°C)	Modified Stock	<b>04067701BT</b>
				100°F (38°C)	Modified Stock	<b>04067701CT</b>
				40°F (4°C)	Modified Stock	<b>04067701DT</b>
				60°F (16°C)	Modified Stock	<b>04067701ET</b>
				Adj. 25°-330°F (-5°-165°C)	Stock	<b>04067711</b>

① Supplied with 6-foot (1.8 m) cord—no plug.

### How to Order

After determining the drum size, volts, watts and temperature sensing requirements, specify the corresponding Watlow code number and quantity desired.

### Availability

**Stock:** Drum heaters without thermostats and those with adjustable thermostats are available for same day shipment if order is received by 11:00 a.m. CST.

**Modified Stock:** Drum heaters with pre-set thermostats require two to three days lead time before being shipped.

**Made-to-Order:** Consult factory

## Flexible Heaters

### Silicone Rubber

#### Stock Product Offering PVC Wirewound Conduit Heaters

Watlow's conduit heater simplifies bending PVC plastic conduit to the desired shape right on the job site. Just plug it in and within four to 18 minutes—depending upon heater size—the conduit is ready to be formed by hand into the shape or radius you need.

This lightweight silicone rubber heater is easily wrapped around the conduit because of its flexible, self-conforming construction.

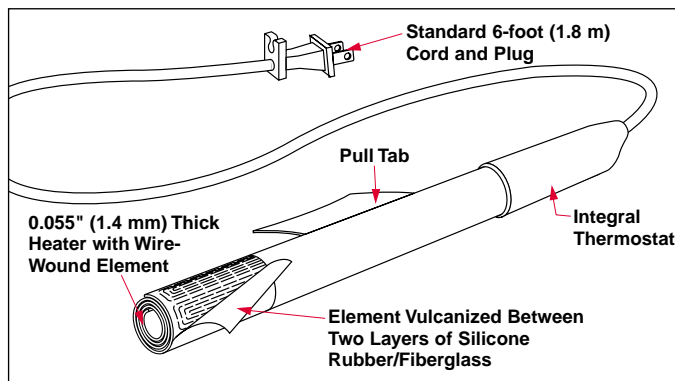

#### Performance Capabilities

- Operating temperatures to 250°F (121°C)
- Handles plastic conduits as large as four inches (100 mm) in diameter

#### Features and Benefits

- **Self-conforming** to cylindrical shapes for a snug fit around the conduit.

- **Portable design** for easy use in the field.
- **Thermostat provided** to protect from overheating.
- **Pull tab** allows easy removal or positioning when the heater is hot.
- **Available for immediate delivery** from stock.

F.O.B.: Columbia, Missouri

Conduit Diameter in. (mm)	Length in. (mm)	Watts	Volts	Temp. Limit °F (°C)	Warm-up Time	Code No.
½ to 1 ½ (15-40)	12 (300)	180	120	250 (121)	4-10 minutes	<b>05712082</b>
2 to 4 (50-100)	25 (635)	950	120	250 (121)	7-18 minutes	<b>14825081</b>

#### How To Order

Choose between the two sizes available. Specify the Watlow code number and quantity desired.

#### Availability

**Stock:** Both sizes are available for immediate delivery from stock.

**Made-to-Order:** Consult factory

# Flexible Heaters

F.O.B.: Anaheim, California

## Silicone Rubber

### Stock Product Offering

#### Composite Flexible Stock Heaters

The composite bonding industry is a large field that is expanding into a variety of areas. One of the primary fields that utilize flexible heaters for curing is the aerospace industry. Watlow offers a stock list of heaters commonly used for composite bonding and curing. The design includes equal length circuits and a no-heat tab for temperature uniformity. Also, the contact surface is made of a smooth silicone to prevent composite surface imperfections. The heaters are fiberglass reinforced to provide lasting field service durability and life.

#### Features and Benefits

- Standard 5 W/in<sup>2</sup>
- 120V~(ac) (standard)/ 240V~(ac) (option) single phase
- Customized leads
- Field service ease
- Equal length circuits— minimum 2 inch x 2 inch tab w/radius
- Smooth contact surface
- UL® recognized

#### Applications

- Aerospace industry
  - Repair
  - Fabrication
- Composite bonding processes

#### Heat Mapping Certification

Heat mapping certification is available on customer request at an additional charge.

- ±10°F conformity
- Serialized and records maintained five years minimum

#### Availability

- **Stock:** 24 hours
- **Heat mapping:** One week
- **Made-to-Order:** Two weeks — a net set-up charge will be applied



Size		Code Number
in.	(mm)	
6 x 6	(180)	<b>L060080509S</b>
6 x 10	(300)	<b>L060120510S</b>
8 x 8	(320)	<b>L080100505S</b>
8 x 12	(480)	<b>L080140501S</b>
10 x 10	(500)	<b>L100120506S</b>
10 x 12	(600)	<b>L100140501S</b>
10 x 18	(900)	<b>L100200503S</b>

Size		Code Number
in.	(mm)	
12 x 12	(700)	<b>L120140510S</b>
12 x 18	(1080)	<b>L120200506S</b>
12 x 24	(1440)	<b>L120260504S</b>
16 x 16	(1280)	<b>L160180502S</b>
18 x 18	(1620)	<b>L180200502S</b>
20 x 20	(2000)	<b>L200220501S</b>

UL® is a registered trademark of Underwriter's Laboratories, Inc.

**NEW PRODUCT**

## Flexible Heaters

### Silicone Rubber

#### Modular Gas Line Heaters

##### Gas Delivery

TEOS, BCl<sub>3</sub>, AlCl<sub>3</sub>, ClF<sub>3</sub> and DCS are gases that condense or liquefy due to a phase shift at low temperatures. The condensation occurs in the gas line and puddles in the shower head before being injected into the vacuum chamber. A substantial number of wafer defects will occur if liquefied gases are injected into the vacuum chamber. Uniform heating of the lines will prevent condensation. TEOS lines are typically heated above 194°F (90°C) and BCl<sub>3</sub> above 86°F (30°C), depending on pressure and flow rate. The optimum line temperature will vary depending on the process parameters.

##### Specifications

- Watt density: 2.5 W/in<sup>2</sup> (0.39 W/cm<sup>2</sup>) on gas line O.D.
- UL® recognized for U.S. and Canadian safety standards
- Heaters and insulators meet UL94-HB flammability requirements
- Insulated straight fillers for 100 percent line coverage—elbows and tees are trim-to-fit to proper length
- I.D. available: ¼, ⅜, ½, ¾ inch (6, 10, 13, 19 mm)
- 120V standard, other voltages available

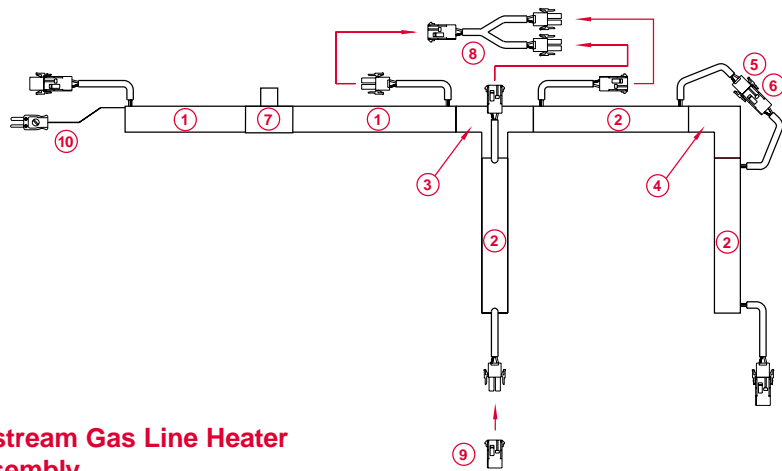

#### Upstream Gas Line Heater Assembly

- 1 9 inch (229 mm) heater with thermocouple. Heater leads have male plug on one end and a female cap on the other end. Heater materials UL® rated to 392°F (200°C).
- 2 6 inch (152 mm) heater. Heater leads, see 1.
- 3 Union tee insulator.
- 4 90° union elbow insulator.
- 5 Male plug, amp p/n 1-480698-0 w/ sockets amp p/n 350689-1.
- 6 Female cap, amp p/n 1-480699-0 w/ pins amp p/n 350690-1.
- 7 Valve or regulator.
- 8 Y Connector: one female cap on one end; two male plugs on the other end.
- 9 Dead plug (sealed).
- 10 Type J thermocouple w/ male mini-plug (optional).
- 11 High-temp plastic snaps 212°F (100°C).
- 12 ⅜ inch (10 mm) wall, silicone rubber, closed cell sponge.

Flexible Heaters

# Flexible Heaters

## Silicone Rubber

### Modular Gas Line Heaters

#### Standard Gas Line Diameter

##### $\frac{1}{4}$ Inch (6 mm) O.D. Tubing (Stock)

$\frac{1}{4}$ Inch (6 mm) Heater I.D. x Length inches (mm)	Description	Volts	Watts	Amps	Watlow Code Number	
					without T/C	with Type J T/C
6 (152)	Heated straight	120	12	0.10	<b>008060C1</b>	<b>008060C1A</b>
9 (229)	Heated straight	120	18	0.15	<b>008090C1</b>	<b>008090C1A</b>
12 (305)	Heated straight	120	24	0.20	<b>008120C1</b>	<b>008120C1A</b>
18 (457)	Heated straight	120	36	0.30	<b>008180C1</b>	<b>008180C1A</b>
24 (610)	Heated straight	120	48	0.40	<b>008240C1</b>	<b>008240C1A</b>
36 (914)	Heated straight	120	72	0.60	<b>008360C1</b>	<b>008360C1A</b>
18 (457)	Straight insulator	N/A	Trim-to-fit	Insulator	<b>008180C0</b>	
* Elbow	90° Union Elbow insulator	N/A	Trim-to-fit	Insulator	<b>008020C0</b>	
* T	Union Tee insulator	N/A	Trim-to-fit	Insulator	<b>008030C0</b>	

##### $\frac{3}{8}$ Inch (10 mm) O.D. Tubing

$\frac{3}{8}$ Inch (6 mm) Heater I.D. x Length inches (mm)	Description	Volts	Watts	Amps	Watlow Code Number	
					without T/C	with Type J T/C
6 (152)	Heated straight	120	18	0.15	<b>012060C1</b>	<b>012060C1A</b>
9 (229)	Heated straight	120	27	0.23	<b>012090C1</b>	<b>012090C1A</b>
12 (305)	Heated straight	120	36	0.30	<b>012120C1</b>	<b>012120C1A</b>
18 (457)	Heated straight	120	54	0.45	<b>012180C1</b>	<b>012180C1A</b>
24 (610)	Heated straight	120	71	0.60	<b>012240C1</b>	<b>012240C1A</b>
36 (914)	Heated straight	120	107	0.90	<b>012360C1</b>	<b>012360C1A</b>
18 (457)	Straight insulator	N/A	Trim-to-fit	Insulator	<b>012180C0</b>	
* Elbow	90° Union Elbow insulator	N/A	Trim-to-fit	Insulator	<b>012020C0</b>	
* T	Union Tee insulator	N/A	Trim-to-fit	Insulator	<b>012030C0</b>	

##### $\frac{1}{2}$ Inch (13 mm) O.D. Tubing (Stock)

$\frac{1}{2}$ Inch (6 mm) Heater I.D. x Length inches (mm)	Description	Volts	Watts	Amps	Watlow Code Number	
					without T/C	with Type J T/C
6 (152)	Heated straight	120	24	0.20	<b>016060C1</b>	<b>016060C1A</b>
9 (229)	Heated straight	120	36	0.30	<b>016090C1</b>	<b>016090C1A</b>
12 (305)	Heated straight	120	48	0.40	<b>016120C1</b>	<b>016120C1A</b>
18 (457)	Heated straight	120	72	0.60	<b>016180C1</b>	<b>016180C1A</b>
24 (610)	Heated straight	120	96	0.80	<b>016240C1</b>	<b>016240C1A</b>
36 (914)	Heated straight	120	144	1.20	<b>016360C1</b>	<b>016360C1A</b>
18 (457)	Straight insulator	N/A	Trim-to-fit	Insulator	<b>016180C0</b>	
* Elbow	90° Union Elbow insulator	N/A	Trim-to-fit	Insulator	<b>016020C0</b>	
* T	Union Tee insulator	N/A	Trim-to-fit	Insulator	<b>016030C0</b>	

\* For use on Micro-Fit® weld fittings.

Micro-Fit® is a registered trademark of CAJON Company, A SWAGELOK® Company.

## Flexible Heaters

### Silicone Rubber

### Modular Gas Line Heaters

#### Standard Gas Line Diameter

**3/4 Inch (19 mm) O.D. Tubing**

3/4 Inch (19 mm) Heater I.D. x Length inches (mm)	Description	Volts	Watts	Amps	Watlow Code Number	
					without T/C	with Type J T/C
6 (152)	Heated straight	120	36	0.30	<b>024060C1</b>	<b>024060C1A</b>
9 (229)	Heated straight	120	54	0.45	<b>024090C1</b>	<b>024090C1A</b>
12 (305)	Heated straight	120	71	0.60	<b>024120C1</b>	<b>024120C1A</b>
18 (457)	Heated straight	120	107	0.90	<b>024180C1</b>	<b>024180C1A</b>
24 (610)	Heated straight	120	142	1.19	<b>024240C1</b>	<b>024240C1A</b>
36 (914)	Heated straight	120	213	1.78	<b>024360C1</b>	<b>024360C1A</b>
18 (457)	Straight insulator	N/A	Trim-to-fit	Insulator	<b>024180C0</b>	
* Elbow	90° Union Elbow insulator	N/A	Trim-to-fit	Insulator	<b>024020C0</b>	
* T	Union Tee insulator	N/A	Trim-to-fit	Insulator	<b>024030C0</b>	

#### Standard Designs

#### VCR Union Heaters/Insulators

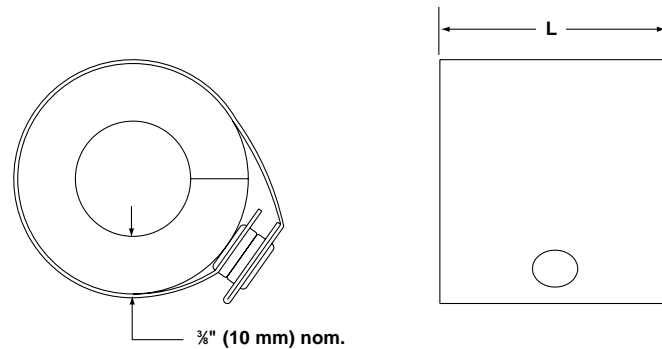

I.D. x Length inches (mm)	Description	Volts	Watts	Amps	Watlow Code Number	
					without T/C	with Type J T/C
7/8 x 1 1/4 (22 x 44)	7/8" (6 mm) VCR Union heater	120	10	0.09	<b>01702783</b>	<b>01702783A</b>
3/4 x 1 1/2 (19 x 38)	3/4" (6 mm) VCR Union insulator	N/A	N/A	N/A	<b>02401580</b>	N/A
1 1/4 x 1 1/2 (32 x 38)	1/2" (13 mm) VCR Union heater	120	12	0.10	<b>03901581</b>	<b>0301581A</b>
1 1/4 x 1 1/2 (32 x 38)	1/2" (13 mm) VCR Union insulator	N/A	N/A	N/A	<b>03901580</b>	N/A

# Flexible Heaters

## Silicone Rubber

### Modular Gas Line Heaters

#### VCR Valve Heaters

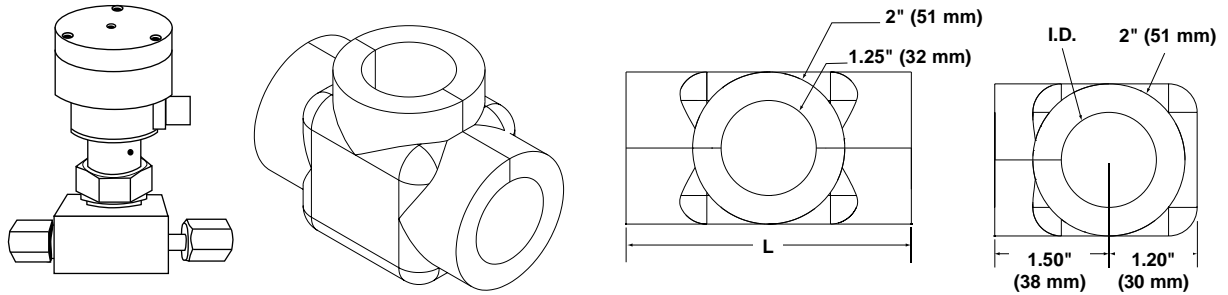

Tube Diameter inch (mm)	I.D. inch (mm)	Fitting Type	Length inches (mm)	Watts	Amps @ 120V	Watlow Code Number
¼ (6)	⅞ (22)	Male VCR Valve heater	3.00 (76)	18	0.15	<b>03104786</b>
¼ (6)	⅞ (22)	Female VCR Valve heater	4.75 (121)	28	0.24	<b>04704893</b>
½ (13)	1 ¼ (32)	Male VCR Valve heater	3.75 (95)	27	0.23	<b>03804782</b>
½ (13)	1 ¼ (32)	Female VCR Valve heater	6.51 (165)	47	0.39	<b>04706690</b>

**Note:** Heaters fit Nupro® BN and BK series valves.

#### Accessories

Part	Description	Watlow Code Number
Y Connector*	Power splitter: 1 female, 2 male	<b>Z5303-2</b>
Female Dead Plug*	Insulating plug for last connector in chain	<b>Z5309-2</b>
Type J Thermocouple	12 inch (305 mm) 24 ga Type J Teflon® w/mini plug	<b>Z5786</b>
Type K Thermocouple	12 inch (305 mm) 24 ga Type K Teflon® w/mini plug	<b>Z5639</b>
Male Dead Plugs*	Insulating plug for last connector in chain	<b>Z6332</b>
Y Connector*	Power splitter: 2 female, 1 male	<b>Z6333</b>
Adaptor*	Female to male	<b>Z6334</b>
Adaptor*	Male to female	<b>Z6335</b>
Extender*	6 inch (152 mm)	<b>Z6374</b>

\*All connectors use AMP Mate-N-Lok® connectors.

Y-adaptors and dead plugs

Sensor Pocket thermocouple: 12 in (305 mm) long, Type J or K, Teflon® insulated, #24 AWG, 2-prong mini-plug connector

Interconnects with Watlow temperature control consoles

Nupro® is a registered trademark of SWAGELOK® Inc.

Mate-N-Lok® is a registered trademark of AMP Incorporated.

Teflon® is a registered trademark of E.I. du Pont de Nemours & Company.

**NEW PRODUCT**

## Flexible Heaters

### Silicone Rubber

#### Modular Pump Line Heaters

The tight contact fit of Watlow's pump line heaters provide superior, uniform heating of transfer lines.

#### Agency Certification, Recognition Compliance, and Approvals

(Contact factory for specific application and approvals)

- Complies with SEMI S2-93 standards
- UL® recognized for U.S. and Canadian safety standards
- CE, VDE
- NEC (National Electrical Code), Article #427-23
- UL® Listed available

#### General Specifications

- Heater and jacket material: reinforced silicone rubber fabric
- Color:  
Insulation and outer jacket: gray  
Heater: red-orange

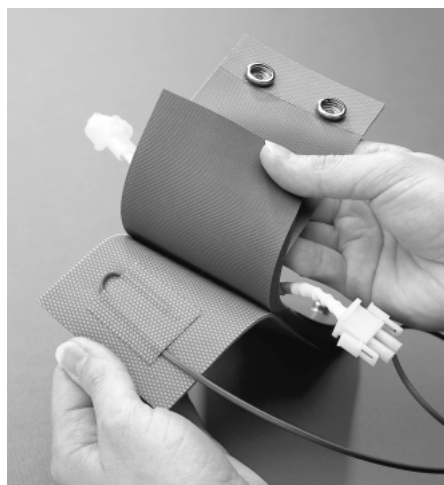

Sensor Pocket™ built-in to all straight length heaters 3 inches (76 mm) long and greater; one per heater.

Velcro® is a registered trademark of Velcro Industries B.V.

UL® is a registered trademark of Underwriter's Laboratories, Inc.

Teflon® is a registered trademark of E.I. du Pont de Nemours & Company.

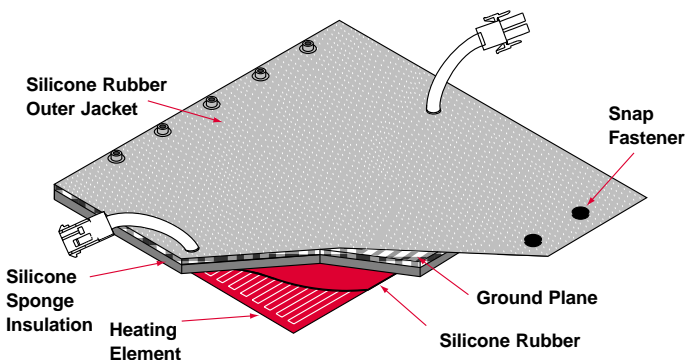

- Snap type fasteners: ½ inch (13 mm) nominal diameter metal construction with nylon cover; maximum operating temperature 392°F (200°C)
- Velcro® fasteners available
- 120 and 208V~(ac) standard. Consult factory for other voltages.
- Power lead wires: 4 inch (102 mm) #18 AWG UL® 1180/CSA Teflon® insulated, rated 10A, leadwire pair encapsulated in reinforced silicone rubber sleeving
- Heaters interconnectable up to a 10A circuit
- **New low watt density:**  
1.5-2 inch diameter, 1.5 W/in<sup>2</sup> (0.23 W/cm<sup>2</sup>)  
3-4 inch diameter, 1.25 W/in<sup>2</sup> (0.19 W/cm<sup>2</sup>)

Flexible Heaters



**Quick Ship**

• Same day shipment on stock units with orders received by 11:00 a.m. CST.

## Flexible Heaters

### Kapton® Material

A thin, lightweight organic polymer film, Kapton® provides excellent tensile strength, tear resistance and dimensional stability. This heater is ideal for applications requiring low outgassing in a vacuum, or resistance to radiation, fungus and chemicals. Kapton® is also very resistant to solvents.

#### Performance Capabilities

- For operating environments as low as -319°F (-195°C), heater temperature as high as 392°F (200°C)
- Watt densities to 50 W/in<sup>2</sup> (7.75 W/cm<sup>2</sup>)<sup>①</sup>

#### Features and Benefits

- **Excellent physical and electrical properties** result in thermal stability over a wide temperature range.
- **Transparent Kapton® material** allows inspection of internal details.
- **Resists radiation and fungus**, allowing its use in a wide range of applications.
- **UR® and cUR®** available on many custom designs.

#### Applications

- Military/aerospace, where low outgassing properties are required
- Medical, where thorough cleaning or sterilization is needed
- Laboratory research
- Photographic equipment
- Optical equipment
- LCD displays
- Computer equipment

#### Standard Specifications

**Thickness:** 0.007 inch (0.2 mm)

**Flexibility (min. radius):** 1/32 inch (0.8 mm)

**Weight:** 1.5 oz./ft<sup>2</sup> (0.05 g/cm<sup>2</sup>)

**Operating temperature:** ②

Maximum: 392°F (200°C)  
Minimum: -319°F (-195°C)

Kapton® and Teflon® are registered trademarks of E.I. du Pont de Nemours & Company.

UR® and cUR® are registered trademarks of Underwriter's Laboratories, Inc.

① Watt density limits are application dependent (operating temperatures, bonding method and heat sink).

② We recommend maximum part temperature at 300°F (150°C). For more information, ask for technical letter #4, Kapton® heaters.

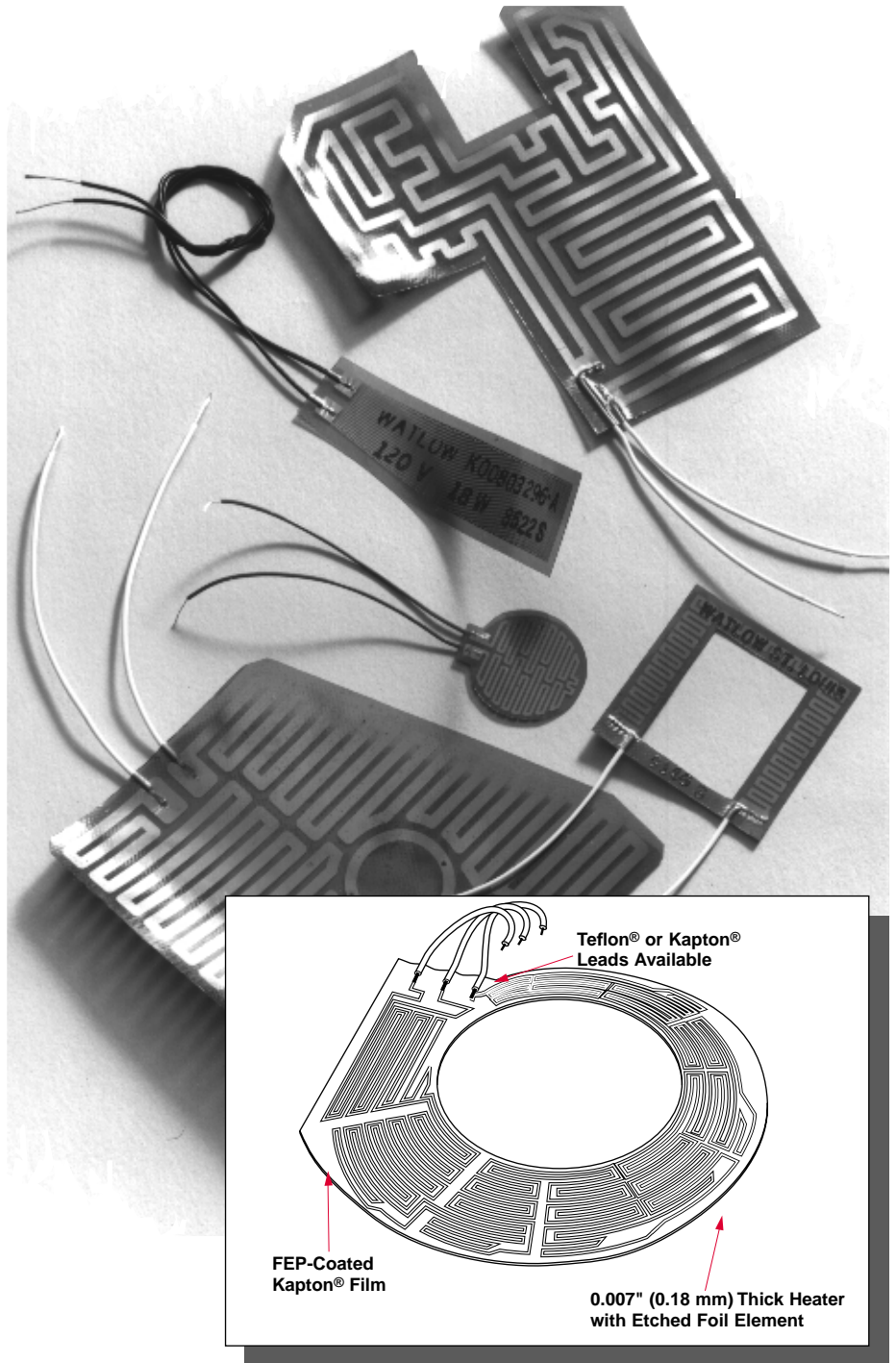

Flexible Heaters

**Maximum operating watt density:**

At 77°F (25°C) in open air:  
7 W/in<sup>2</sup> (1 W/cm<sup>2</sup>)  
At 300°F (150°C): 10 W/in<sup>2</sup>

**Watt density rating on stock units:** 5 W/in<sup>2</sup> (0.8 W/cm<sup>2</sup>)

**Dielectric strength:**  
Minimum V~(ac): 1000

**Flammability rating:**

Self-extinguishing

**Heater size limitations:** 20 x 26 inches (510 mm x 660 mm)

**Weight loss (outgassing):**  
0.51 percent

**Standard lead length:** 12 inches (305 mm) Teflon® E

# Flexible Heaters

FO.B.: Columbia, Missouri

## Kapton Material

### Options

#### Stock

- Pressure Sensitive Adhesive Surface (PSAS) (see [page 165](#) for more information)

#### Made-to-Order

- PSAS
- Factory bonding
- Holes, cutouts, notches
- Special leads

Width in. (mm)	Length in. (mm)	Volts	Watts	Availability	Code Number 28V	Code Number 120V~(ac)
0.5 (13)	2 (50)	28	5	Stock	<b>K005020C5</b>	
1 (25)	1 (25)	28	5	Stock	<b>K010010C5</b>	
1 (25)	3 (75)	28	15	Stock	<b>K010030C5</b>	
1 (25)	5 (125)	120	25	Stock		<b>K010050C3</b>
1 (25)	15 (380)	120	75	Stock		<b>K010150C3</b>
2 (50)	10 (255)	120	100	Stock		<b>K020100C3</b>
3 (75)	5 (125)	120	75	Stock		<b>K030050C3</b>
4 (100)	4 (100)	120	80	Stock		<b>K040040C3</b>
5 (125)	5 (125)	120	125	Stock		<b>K050050C3</b>

Approx. net weight: 1.5 ounces/ft<sup>2</sup> (0.05 g/cm<sup>2</sup>)

#### How to Order

Determine width, length, volts and watts. Specify the code number and quantity if the heater is listed in the stock list above. To specify PSAS add **A** to code number. For **made-to-order** heaters, please provide the following:

- Quantity
- Size (dimensions)
- Voltage
- Wattage/watt density
- Operating temperature
- Options, such as holes, PSAS.

- Will heater be subject to flexing?

#### Availability

**Stock:** Same day shipment of orders received by 11:00 a.m. CST.

**Made-to-Order:** Consult factory

## Special Product Offering

### Kapton® Handy Heater Kit—For Quick Heating Solutions

Watlow offers a convenient way to use Kapton® heaters. The Handy Heater Kit consists of 16 Kapton® heaters—13 rectangular and three circular—in different sizes and resistances. So when you need a small flexible heater in a hurry, you can pick the one that fits your application.

Circuit	Resistance (ohms)	Size (inches)
A	40	½ x 2 ½
B	90	1 x 2 ½
C	145	1 ½ x 2 ½
D	205	2 x 2 ½
E	80	½ x 3 ½
F	165	1 x 3 ½
G	275	1 ½ x 3 ½
H	375	2 x 3 ½
I	130	½ x 5 ¾
J	255	1 x 5 ¾
K	28	1 x 1 ½
L	13	½ x 1 ½
M	32	1 O.D.
N	180	2 O.D.
O	185	4 O.D.
P	45	1 x 1 ¾

#### Other Features

- The heater sheet can be ordered with or without pressure sensitive adhesive (PSAS), depending on your needs. To specify PSAS add **A** to code number.
- The kit comes with instructions for wiring, lead attachment and selection and installation. Pre-tinned solder pads are provided for easy lead connections.
- The instructions also show you how to dial in your desired wattage using a variable voltage transformer.
- The heaters can be wired individually, in series, or parallel for hundreds of variations to satisfy your special application.

FO.B.: Columbia, Missouri

Kapton® Kit		
Description	Availability	Code Number
Heater Kit Only	Stock	<b>K05711980</b>
Kit with PSAS	Stock	<b>K05711980A</b>
Kit with 3 Lead Pairs	Stock	<b>K05711980L</b>
Kit with PSAS and Leads	Stock	<b>K05711980AL</b>

Individual heaters are K05711980-circuit letter.

#### Availability

**Stock:** Same day shipment of orders received by 11:00 a.m. CST.

## Flexible Heaters

### Neoprene

Watlow's neoprene heater provides an economical method of supplying heat up to 250°F (120°C) where the higher temperature and watt density capabilities of the silicone rubber heater are not required. Like silicone rubber, neoprene is thin, strong, lightweight and convenient to apply.

#### Performance Capabilities

- Operating temperatures up to 250°F (120°C)
- Watt densities up to 10 W/in<sup>2</sup> ①

#### Features and Benefits

- **Resists weathering, abrasion and many chemicals** for longer life and greater versatility.
- **Custom shaped** to fit your part.
- **Lightweight construction** allows use in applications where weight is critical.
- **Responds quickly** to controls because of heater's low thermal-mass.

#### Applications

- Foodservice tables
- Battery heating (freeze protection)
- Photographic chemical tanks

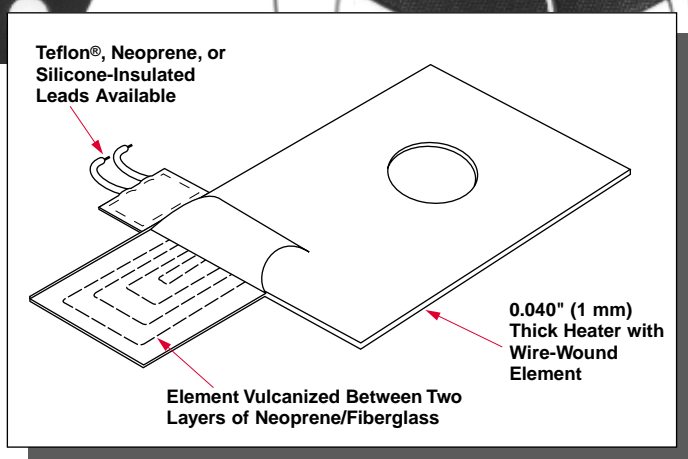
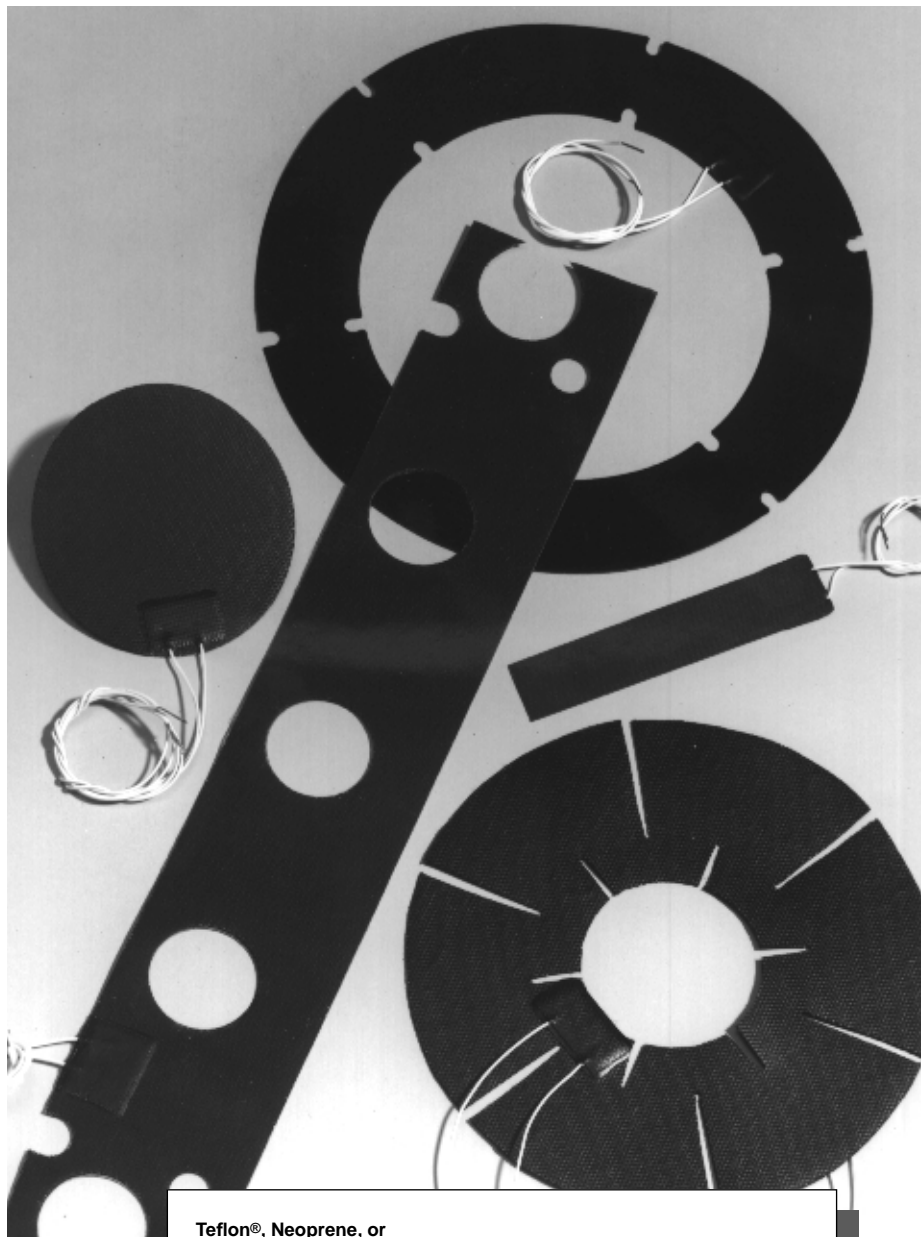

Teflon® is a registered trademark of E.I. du Pont de Nemours & Company.

① Watt density limits are application dependent (operating temperatures, bonding method and heat sink).

# Flexible Heaters

## Neoprene Applications and Technical Data

### Determining Maximum Allowable Watt Density

This graph illustrates the maximum recommended heater watt density at various metal part or ambient air temperatures. The graph is based

on wire-wound elements, cemented with RTV, with no backside insulation and using an on-off controller. See the graph explanation on [page 170](#) in the **Silicone Rubber** section for further clarification.

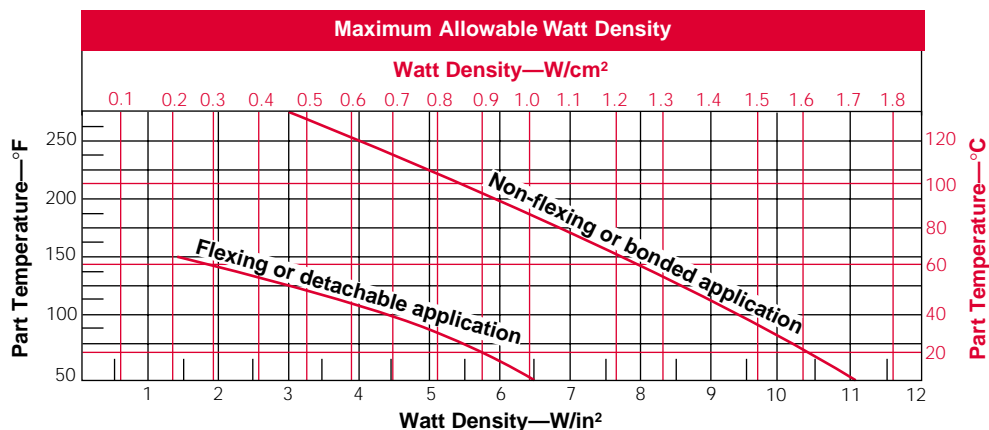

## Options

Neoprene heaters can be designed to include the following options:

- Attachment techniques: PSAS, RTV, factory vulcanizing, mechanical fasteners
- Special leads
- Holes, cutouts and notches
- Thermostats

Detailed information on each of these options can be found on [pages 165 to 168](#) in the **Flexible Shapes and Geometries** section.

**F.O.B.: Columbia, Missouri**

### How to Order

All neoprene heaters from Watlow are **made-to-order**. Please provide the following application information to place an order or request a quote:

- Size (dimensions)
- Voltage
- Wattage/watt density
- Operating temperature
- Options (leads, thermostats, attachment techniques, etc.)
- Quantity

### Availability

Consult factory for these **made-to-order** units.

## Flexible Heaters

### HT Foil

This high temperature etched foil heater from Watlow is designed for demanding applications requiring operating temperatures up to 1100°F (595°C). The heater, only 0.030 inch (0.76 mm) thick, is insulated with a mica sheet. The heater is fairly rigid and must be securely and uniformly clamped from both sides for support and good heat transfer during operation.

#### Performance Capabilities

- Operating temperatures to 1100°F (595°C)
- Watt densities to 110 W/in<sup>2</sup> (17 W/cm<sup>2</sup>) when operating at 500°F (260°C). Watt density should decrease as temperature increases.

#### Features and Benefits

- **High temperatures and watt densities** for more demanding applications.
- **Fast heat-up** due to thin construction and low mass design.
- **Easy to design** in circular or complex two-dimensional shapes.
- **More uniform part temperatures** are possible with etched foil zoned heating.

#### Applications

- Semiconductor industry: wafer processing equipment
- High temperature platens for laminating presses

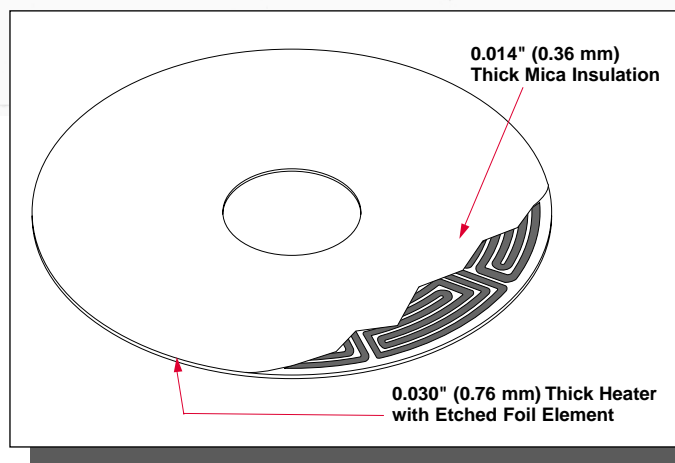

# Flexible Heaters

## HT Foil

### Applications and Technical Data

#### **Installation and Mounting**

The HT Foil heater is designed to be permanently clamped. If the lead connection points are within the clamped area, a relief in one of the clamped surfaces is required to allow adequate clamping of the active heater area.

For further details on mounting methods, see **Watlow technical letter #6**, flexible heaters.

#### **General Specifications**

Although Watlow doesn't stock HT Foil heaters, there are several specifications common to most of the custom designs. They include:

- **Thickness over heated area:**  
0.030 inch (0.76 mm)
- **Thickness over lead connection area:**  
0.200 inch (5 mm)
- **Dielectric strength—volts ac, minimum:**  
1000V~(ac)
- **Maximum operating temperature:**  
1100°F (593°C)
- **Maximum allowable watt density at various temperatures:**

1000°F (540°C)	20 W/in <sup>2</sup> (3.1 W/cm <sup>2</sup> )
900°F (480°C)	40 W/in <sup>2</sup> (6.2 W/cm <sup>2</sup> )
800°F (425°C)	60 W/in <sup>2</sup> (9.3 W/cm <sup>2</sup> )
700°F (370°C)	75 W/in <sup>2</sup> (11.6 W/cm <sup>2</sup> )
600°F (315°C)	90 W/in <sup>2</sup> (14 W/cm <sup>2</sup> )
500°F (260°C)	110 W/in <sup>2</sup> (17 W/cm <sup>2</sup> )
- **Lead wire—Type MGT 600 volt with Nickel clad Cu conductor:**  
840°F (450°C)

## Options

The following options are possible with HT Foil heaters from Watlow:

- Holes, cutouts, and notches
- Zoned wattage



**Detailed information on holes, cutouts and notches can be found on page 166 in the Flexible Shapes and Geometries section.**

**F.O.B.: Columbia, Missouri**

#### **How to Order**

All HT Foil heaters from Watlow are **made-to-order**. Please provide the following application information to place an order or request a quote:

- Size (dimensions)
- Voltage
- Wattage/watt density
- Operating temperature
- Options (holes, zoned wattage)
- Quantity

#### **Availability**

Consult factory